

## ● Specification

Type	AE630-SW	AE1000-SW	AE1250-SW	AE1600-SW		AE2000-SWA	AE2000-SW	AE2500-SW	AE3200-SW	AE4000-SWA	AE4000-SW	AE5000-SW	AE6300-SW	
Frame size (A)	630	1000	1250	1600		2000	2000	2500	3200	4000	4000	5000	6300	
Rated insulation voltage (Ui) (50/60Hz)(AC.V)			1000					1000				1000		
Rated operational voltage (Ue) (50/60Hz)(AC.V)			690					690				690		
Rated impulse withstand voltage (Uimp) (kV)			12					12				12		
Utilization category			B					B				B		
Pollution degree			3					3				3		
EMC environment condition (environment A or B) (Note 14)			A					A				A		
Number of poles			3, 4					3, 4				3, 4 (HN, FN) (Note 7)		
Rated current In (CT rating) (A)	630 (Note 5)	1000	1250	1600		2000	2000 (Note 5)	2500	3200	4000	4000	5000	6300	
Current setting Ir (A) (40°C)	WWS WB General use (Current rating adjustable 0.5 to 1.0 × In 0.05 step)	315-346.5-378-409.5- 441-472.5-504-535.5- 567-598.5-630 (Note 5)	500-550-600-650- 700-750-800-850- 900-950-1000	625-687.5-750-812.5- 875-937.5-1000-1062.5- 1125-1187.5-1250	800-880-960-1040- 1120-1200-1280-1360- 1440-1520-1600		1000-1100-1200-1300- 1400-1500-1600-1700- 1800-1900-2000	1000-1100-1200-1300- 1400-1500-1600-1700- 1800-1900-2000 (Note 5)	1250-1375-1500-1625- 1750-1875-2000-2125- 2250-2375-2500	1600-1760-1920-2080- 2240-2400-2560-2720- 2880-3040-3200	2000-2200-2400-2600- 2800-3000-3200-3400- 3600-3800-4000	2000-2200-2400-2600- 2800-3000-3200-3400- 3600-3800-4000	2500-2750-3000-3250- 3500-3750-4000-4250- 4500-4750-5000	3150-3465-3780-4095- 4410-4725-5040-5355- 5670-5985-6300
	WWM Generator protection use (Current rating fixed) (Note 10)	160 ≤ Ir ≤ 630	400 ≤ Ir ≤ 1000	800 ≤ Ir ≤ 1250	1000 ≤ Ir ≤ 1600		1250 ≤ Ir ≤ 2000	800 ≤ Ir ≤ 2000	1600 ≤ Ir ≤ 2500	2000 ≤ Ir ≤ 3200	2500 ≤ Ir ≤ 4000	2500 ≤ Ir ≤ 4000	3150 ≤ Ir ≤ 5000	4000 ≤ Ir ≤ 6300
Rated current of neutral pole (A)	630	1000	1250	1600		2000	2000	2500	3200	4000	2000 (4000) (Note 8)	2500 (5000) (Note 8)	3150 (6300) (Note 8)	
IEC60947-2 EN60947-2 JIS C 8201-2-1	Ultimate breaking capacity Icu (kA rms)	690V AC		65					75			85		
		600V AC		65					75			85		
		240-500V AC		65					85			130 (Note 9)		
		with MCR	690V AC		65					75			85	
			600V AC		65					75			85	
			240-500V AC		65					75			100	
	Bare + External relay	690V AC		25 (Note 1)					45 (Note 1)			65 (Note 1)		
		500V AC		25 (Note 1)					45 (Note 1)			65 (Note 1)		
	Rated service breaking capacity Ics (kA rms) %Icu				100%				100%			100%		
	Rated making capacity Icm (kA peak)	690V AC		143					165			187		
		600V AC		143					165			187		
		240-500V AC		143					187			286		
with MCR		690V AC		143					165			187		
		600V AC		143					165			187		
		240-500V AC		143					165			220		
Bare or Bare + External relay	690V AC		52.5					94.5			143			
	500V AC		52.5					94.5			143			
Rated short time withstand current Icw (kA rms)	1s		65					75			100 (Note 13)			
	2s		60					75			85			
	3s		50					65			85			
Maximum total breaking time (ms)			40 (Note 6)					40 (Note 6)			50 (Note 6)			
Maximum closing time (ms)			80					80			80			
Number of operating cycles (Note 2) (Note 15)	With rated current	690V AC In (Note 16)		5,000			1,500	1,500	1,000	500		1,000		
		690V AC In (Note 17)		10,000			8,000	8,000	8,000	5,000		-		
		Without rated current (Note 17)		25,000 (Note 4)				20,000 (Note 4)			10,000 (3P) / 5,000 (4P)			
Connecting terminal (Note 11)	Horizontal terminal		○				-	○		-	-	-		
	Vertical terminal		○			○ (Note 3)		○		○ (Note 3)	○ (Note 3)			
	Front terminal		○			-		○		-	-			
Outline dimension (mm) H×W×D	Fixed type	3-pole		410×340×290				410×475×290			414×874×290			
		4-pole		410×425×290			410×605×290			414×1004(1134)×290 (Note 8)				
	Drawout type	3-pole		430×300×375			430×435×375		430×439×375		480×889×375			
		4-pole		430×385×375			430×565×375		430×569×375		480×1019(1149)×375 (Note 8)			
Weight (kg) (without Accessory) (Note 12)	Fixed type	3-pole	35	35	35	44	51	52	54	73	141	141	148	
		4-pole	42	42	43	43	54	64	64	67	92	159 (179)	159 (179)	166 (188)
	Drawout type (including cradle)	3-pole	56	56	56	62	81	81	85	101	194	194	208	
		4-pole	70	70	70	75	101	101	106	127	223 (247)	223 (247)	238 (269)	
	Cradle only	3-pole		24			27		33		34	46	98	107
		4-pole		28			32		40		42	58	113 (127)	121 (138)
Marking:CE/UKCA			Self-declaration					Self-declaration			Self-declaration			
CCC recognition (☆:Certified)			☆					☆			☆			
Marine approval (☆:Certified)			☆(NK, LR, DNV(DNV GL), BV, ABS, CCS)					☆(NK, LR, DNV(DNV GL), BV, ABS, CCS)			☆(NK, LR, DNV(DNV GL), BV, ABS)			
Automatic tripping device			Electronic (effective value detection)					Electronic (effective value detection)			Electronic (effective value detection)			

(Note 1) This is the Icu value when the bare main body and the external relay are combined.  
 (Note 2) The number of operating cycles without rated current also includes the number of operating cycles with rated current.  
 (Note 3) AE2000-SWA, AE4000-SWA and AE4000-SW-AE6300-SW apply for only vertical terminal of connecting terminal.  
 (Note 4) This value is max. operating cycle for just ACB body without any accessories.  
 (The max. operating cycles for the accessories like AX, MD, CC, SHT and UVT are half of this value.)  
 (Note 5) Products with low rating types are available. For AE630-SW low rating types (250A, 315A, 500A), DP3 is not available.

AE 630-SW 3 kinds of products with low rating types are available.  
 · 250-275-300-325-350-375-400-425-450-475-500(CT 500A)  
 · 157.5-173.3-189-204.8-220.5-236.3-252-267.8-283.5-299.3-315(CT 315A)  
 · 125-137.5-150-162.5-175-187.5-200-212.5-225-237.5-250(CT 250A)

AE 2000-SW 2 kinds of products with low rating types are available.  
 · 800-880-960-1040-1120-1200-1280-1360-1440-1520-1600(CT 1600A)  
 · 625-687.5-750-812.5-875-937.5-1000-1062.5-1125-1187.5-1250(CT 1250A)

(Note 6) This value means the instantaneous breaking time at shortcircuit interruption.  
 As for accessories (SHT, UVT), refer to page 13 and 14.  
 (Note 7) 4(HN) means the neutral poles current capacity is 50% of the rated current, for 4 poles.  
 4(FN) means the neutral poles current capacity is 100% of the rated current, for 4 poles.  
 (Note 8) ( ) shows the value for 4P FN type.  
 (Note 9) Marine approval value is 138kA.  
 (Note 10) For WM relay, the current setting Ir can be set by 1A except AE630-SW low rating types "CT315A" and "CT250A". For AE630-SW with "CT315A" and "CT250A", it can be set by 0.1A.  
 (Note 11) As for selectable connection, please refer to page 13.  
 (Note 12) These weights include an electronic relay, but don't include other accessories.  
 (Note 13) For 600 ~ 690V AC, Icw at 1s is 85kA.

(Note 14) This product is designed on the basis of environment A. When used under environment B, it might cause electromagnetic interference, and the user would be asked to do countermeasures to reduce these interference.  
 (Note 15) The number of operating cycles is the guideline for the life of the open/close operation in the standard operation environment. These are not guaranteed values.  
 (Note 16) This is the guideline for the life of the open/close operation when periodic inspection and maintenance are performed and consumable parts are not replaced.  
 (Note 17) This is the guideline for the life of the open/close operation when periodic inspection and maintenance are performed and consumable parts are replaced.

(Remark) All models conform the isolating function according to IEC 60947-2.  
 Reverse connection is possible.

# Connections

## Over view (AE630~1600-SW, AE2000~3200-SW)

Connections Type	Horizontal	Vertical (VT)	Front (FT)	Vertical terminal adapter (VTA)	Front terminal adapter (FTA)
Fixed type (FIX)		—	—	 FIX-VTA	 FIX-FTA
Drawout type (DR)		 DR-VT	 DR-FT	 DR-VTA	 DR-FTA

● Connection image : AE630~1600-SW, 3-pole type

## Over view (AE2000-SWA, AE4000-SWA, AE4000~6300-SW)

Connections Type	Vertical (VT) Standard
Fixed type (FIX)	 FIX-VT
Drawout type (DR)	 DR-VT

● Connection image : AE2000-SWA, 3-pole type  
● For AE2000-SWA, AE4000-SWA, AE4000-SW, AE5000-SW and AE6300-SW models, vertical terminal only is available.

## Available connections

Connections		Breakers											
		AE630-SW	AE1000-SW	AE1250-SW	AE1600-SW	AE2000-SWA	AE2000-SW	AE2500-SW	AE3200-SW	AE4000-SWA	AE4000-SW	AE5000-SW	AE6300-SW
Fixed type (FIX)	Horizontal	○	○	○	○	—	○	○	○	—	—	—	—
	FIX-VT	—	—	—	—	○	—	—	—	○	○	○	○
	FIX-VTA	○	○	○	○	—	○	○	○	—	—	—	—
	FIX-FTA	○	○	○	○	—	○	○	○	—	—	—	—
Drawout type (DR)	Horizontal	○	○	○	○	—	○	○	○	—	—	—	—
	DR-VT	○	○	○	○	○	○	○	○	○	○	○	○
	DR-FT	○	○	○	○	—	○	○	○	—	—	—	—
	DR-VTA	○	○	○	○	—	○	○	○	—	—	—	—
	DR-FTA	○	○	○	○	—	○	○	○	—	—	—	—

○ Available

# Appearance and Product structure

## Fixed type

### AE-SW Series

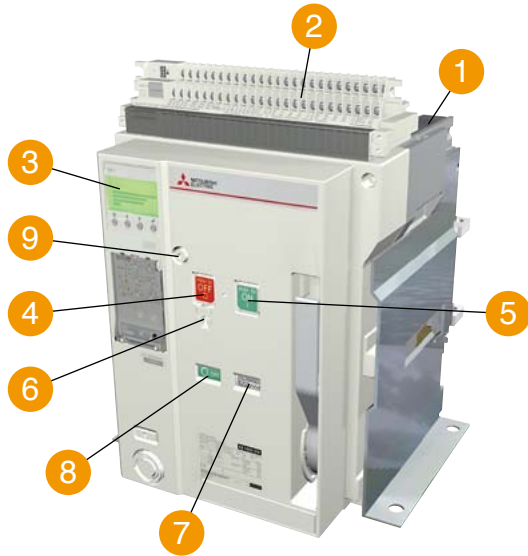

AE1600-SW 3P

- 1 Arc extinguishing chamber
- 2 Control circuit terminal block
- 3 Electronic trip relay
- 4 OFF button
- 5 ON button
- 6 Padlock hook (allows a padlock to be attached to the OFF button)
- 7 Charging indicator
- 8 ON/OFF indicator
- 9 Manual reset button(Optional)

For the fixed type, Lifting hooks (HP) are attached.

## Drawout type

### AE-SW Series

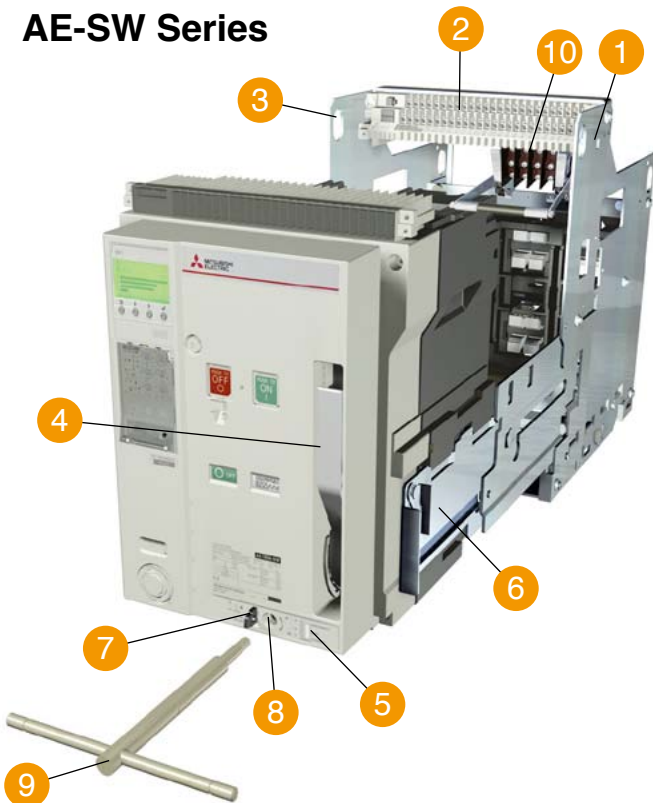

AE1600-SW 3P

- 1 Cradle
- 2 Control circuit terminal block
- 3 Lifting hole
- 4 Charging handle
- 5 Drawout position indicator
- 6 Extension rail
- 7 Lock plate
- 8 Aperture for the drawout handle
- 9 Drawout handle
- 10 Cell switch (Optional)

For the drawout type, Drawout handle is attached.

Fixed type AE2000-SW, AE2500-SW, AE3200-SW

(mm)

Front view

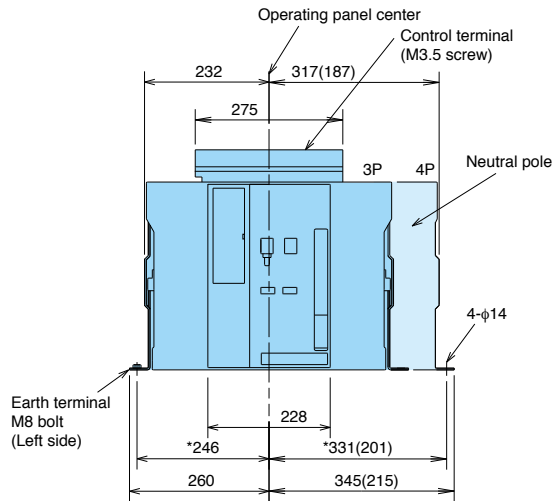

\* : Mounting pitch  
The numerals shown in parentheses are for 3 poles.

Side view

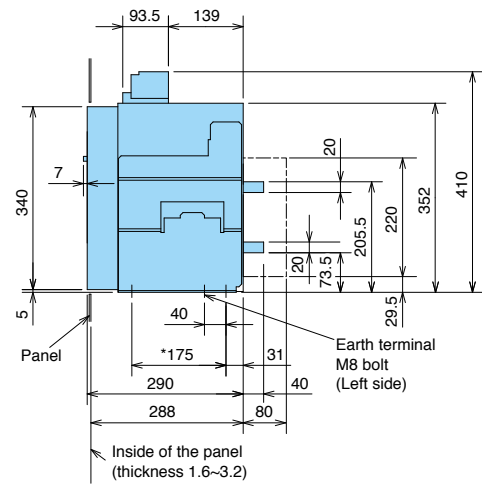

Rear view

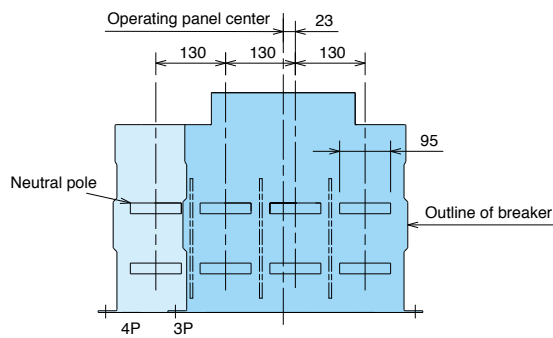

Main circuit terminal dimension

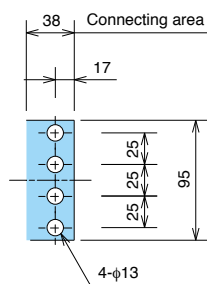

Lifting hooks (HP)

HP is supplied with ACB Fixed type.

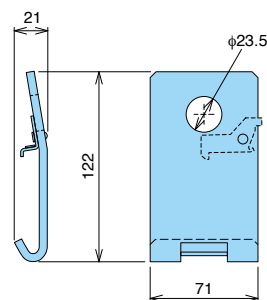

# Outline dimensions

## Fixed type AE4000-SWA

(mm)

Front view

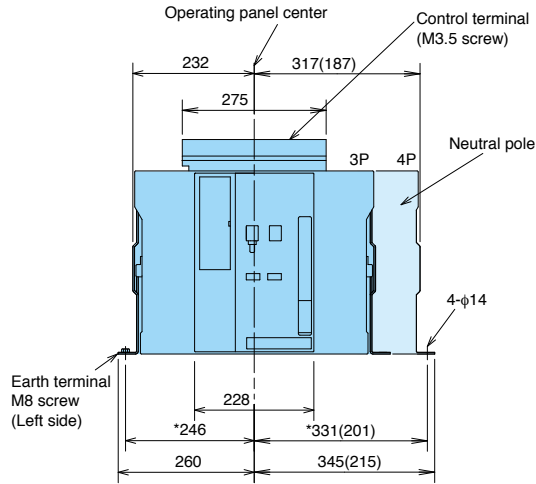

\* : Mounting pitch  
The numerals shown in parentheses are for 3 poles.

Side view

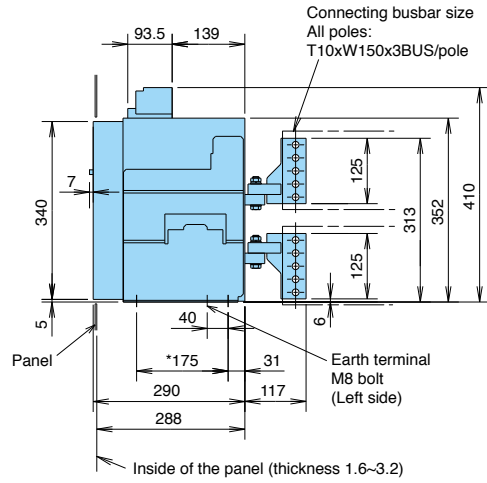

Rear view

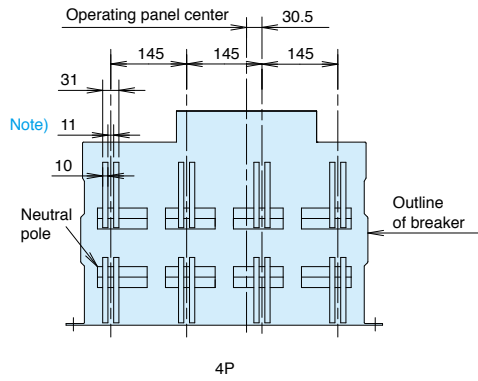
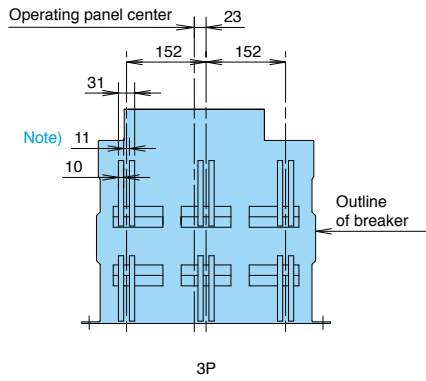

Note) Spacers are not required when fastening connecting conductors (T10). The necessary contact area can be obtained with ACB terminal bent by tightening the screw.

Main circuit terminal dimension

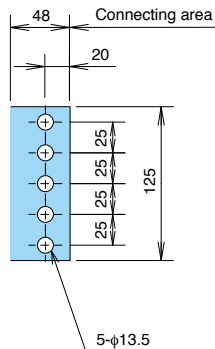

Lifting hooks (HP)

HP is supplied with ACB Fixed type.

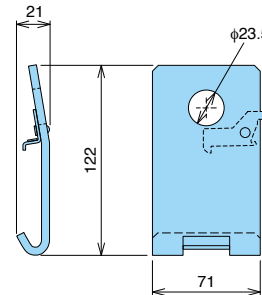

# Outline dimensions

## Drawout type AE2000-SW, AE2500-SW, AE3200-SW

(mm)

Front view

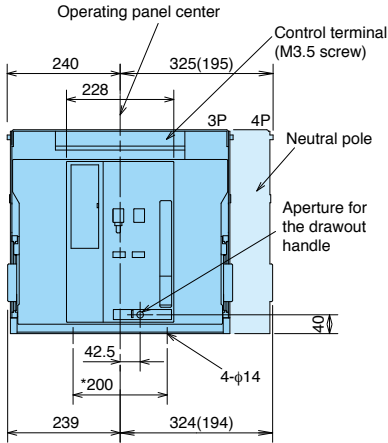

Side view

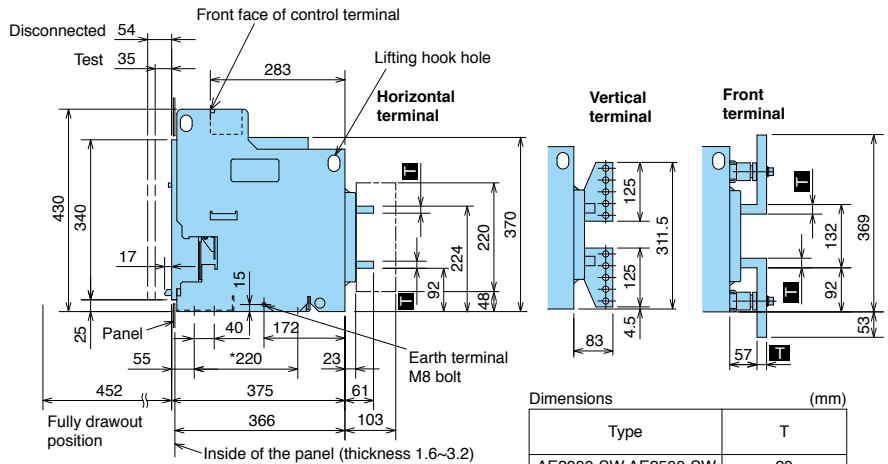

Dimensions (mm)	
Type	T
AE2000-SW AE2500-SW	20
AE3200-SW	25

\* : Mounting pitch  
The numerals shown in parentheses are for 3 poles.

Rear view

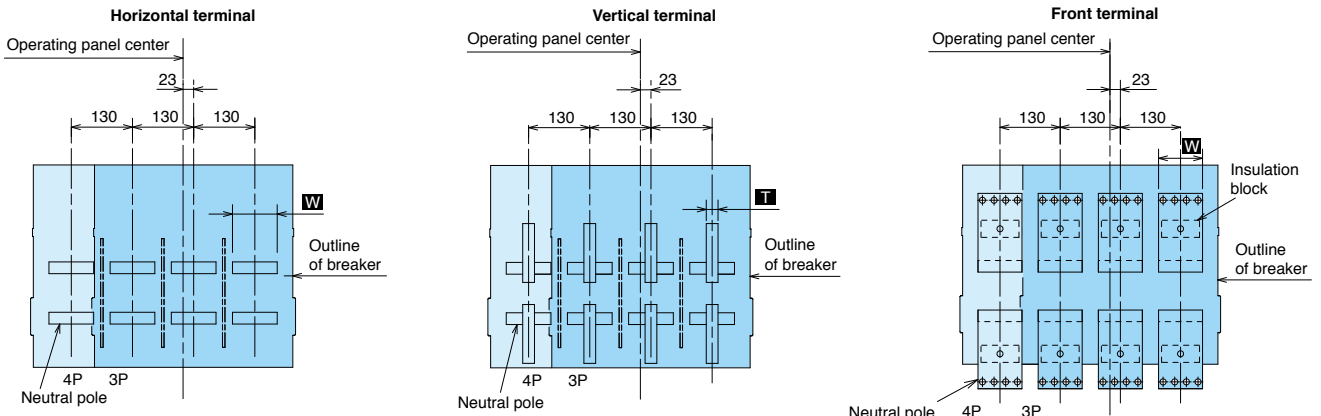

## Main circuit terminal dimensions

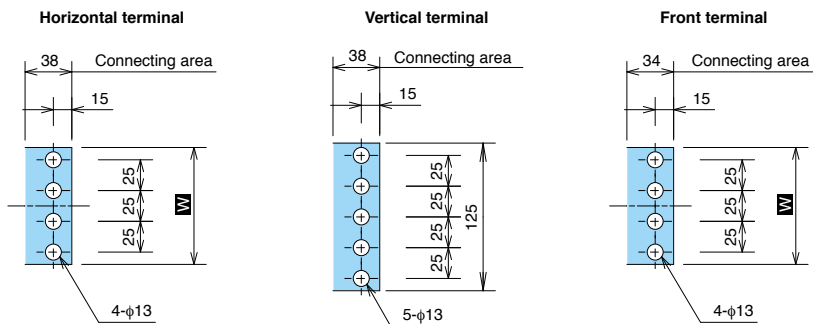

Dimensions (mm)	
Type	W
AE2000-SW AE2500-SW	95
AE3200-SW	103

## Drawout type AE4000-SWA

(mm)

**Front view**

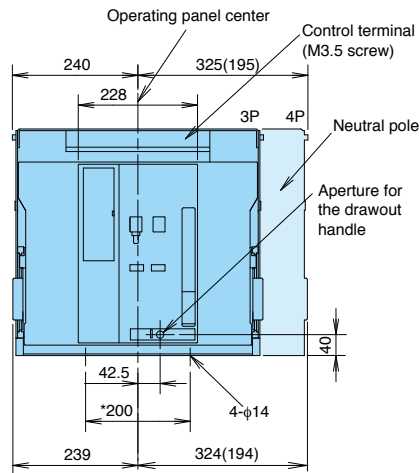

\* : Mounting pitch  
The numerals shown in parentheses are for 3 poles.

**Side view**

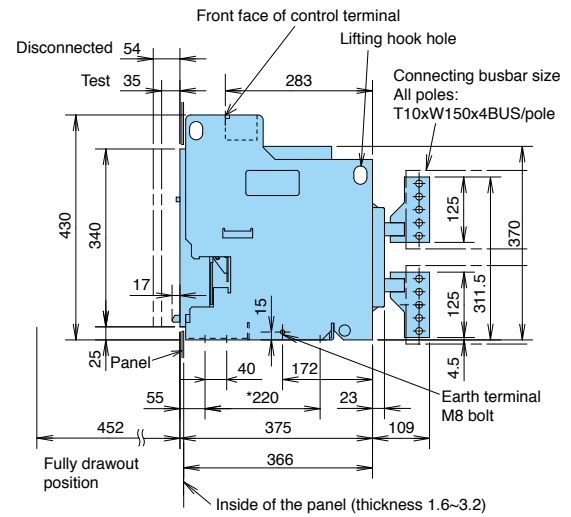

**Rear view**

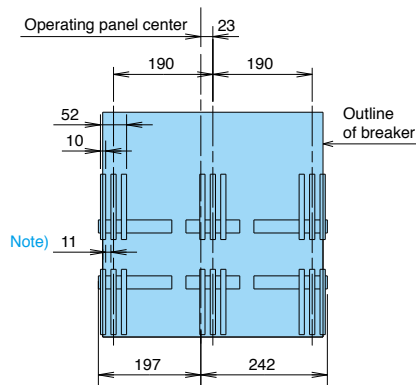

3P

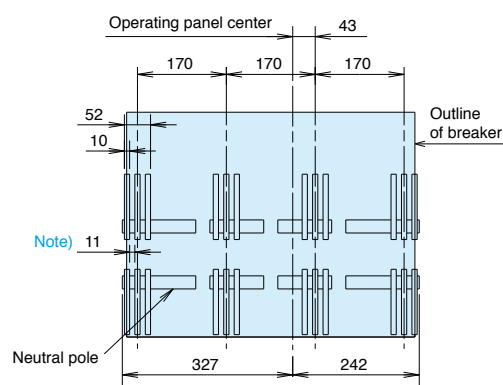

4P

Note) Spacers are not required when fastening connecting conductors (T10). The necessary contact area can be obtained with ACB terminal bent by tightening the screw.

### Main circuit terminal dimension

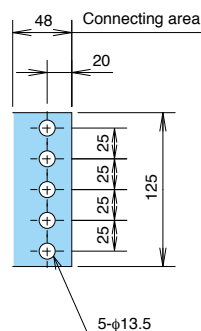

## Operating characteristic curve (for general use : WS)

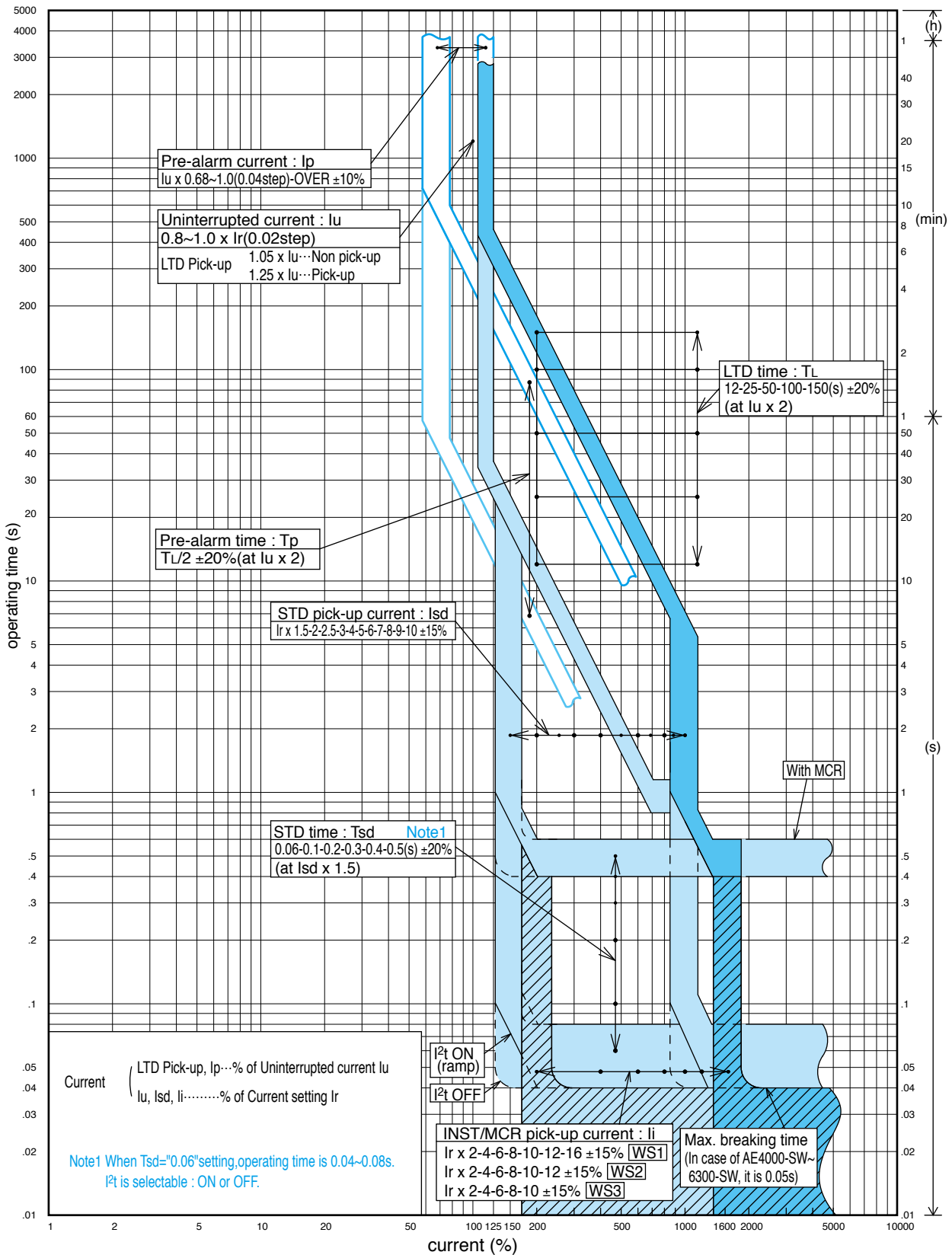

# Operating characteristic curve (for general use : WS relay with Ampere Meter and Fault Memory "DP3")

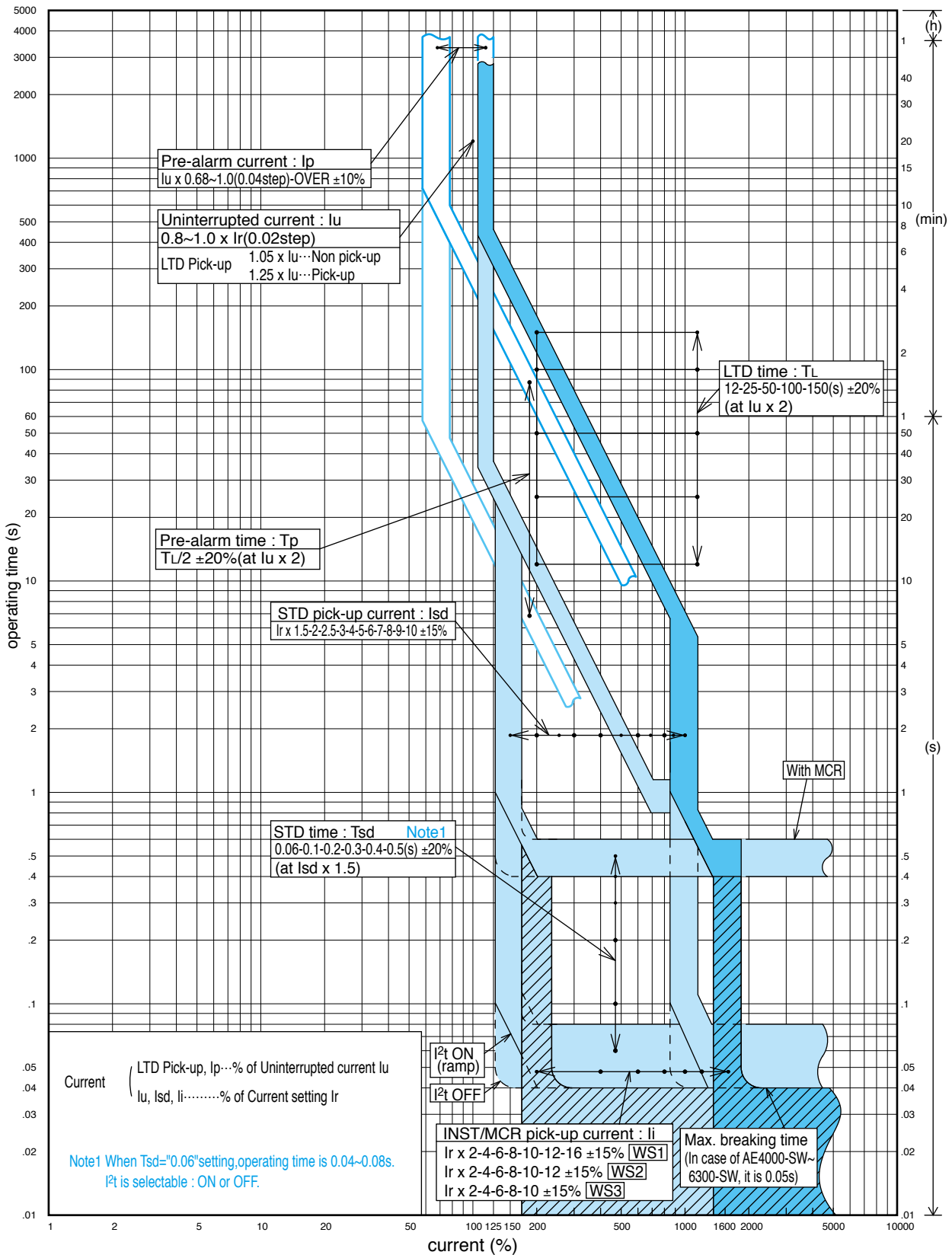

## ■ Operating characteristic curve (for generator protection use : WM)

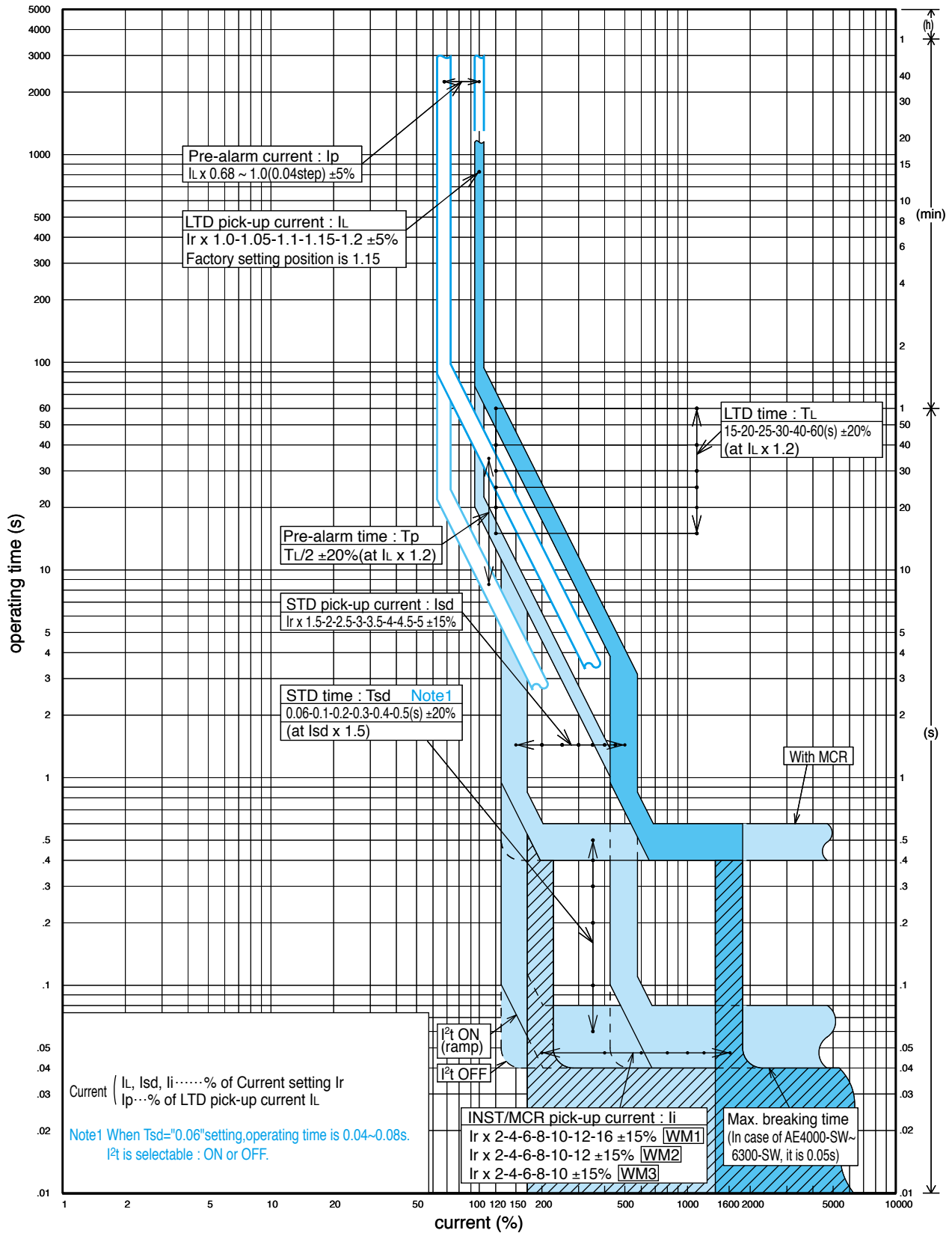

## ■ Operating characteristic curve (for special use : WB)

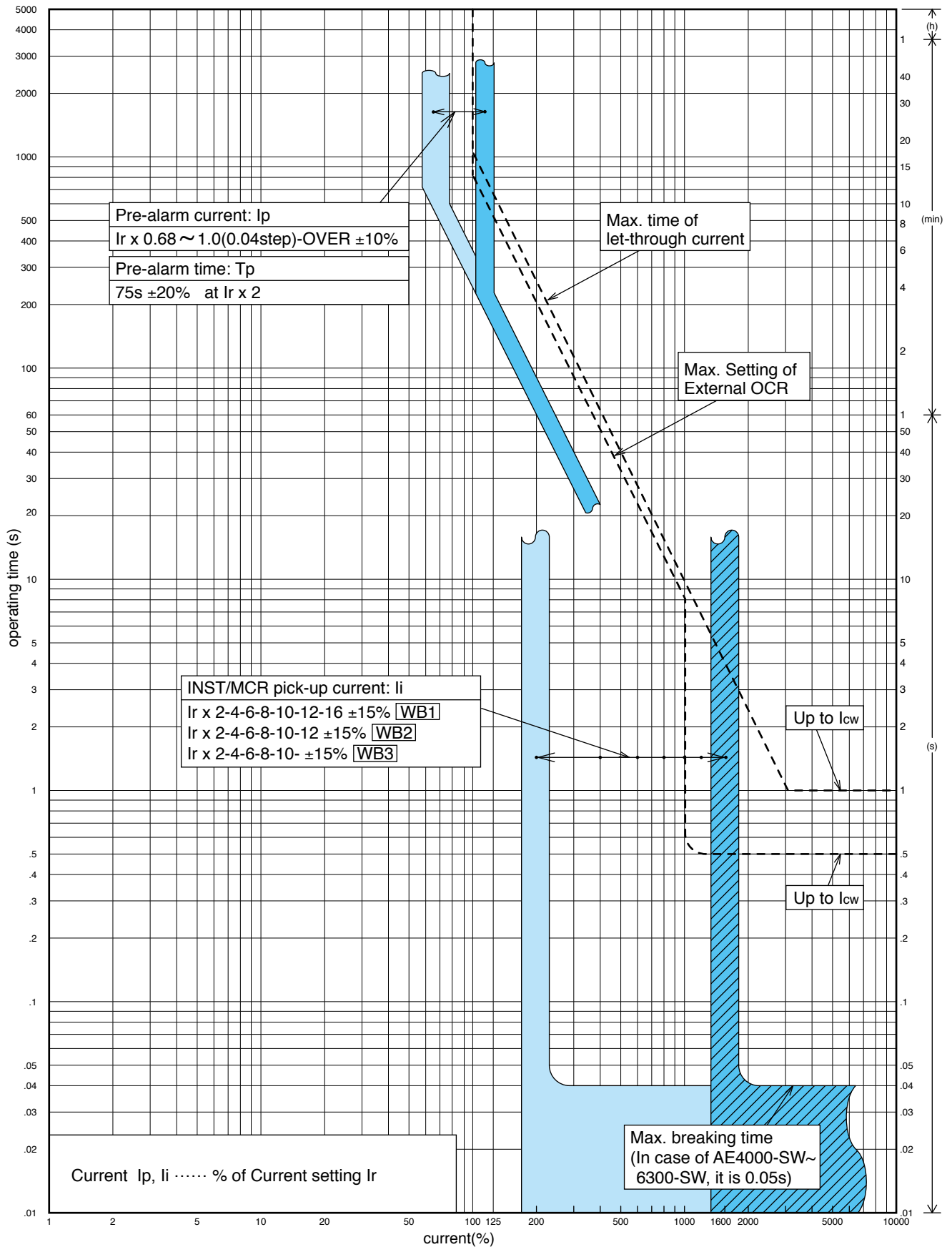

## ■ Operating characteristic curve (for protective coordination use : WF)

[LTD curve setting "a=0.02"]

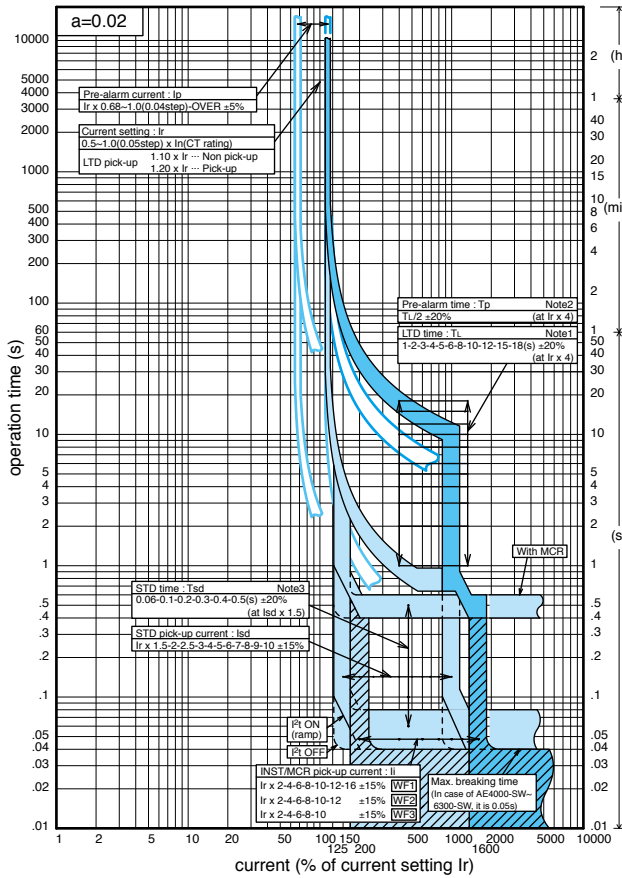

[LTD curve setting "a=1"]

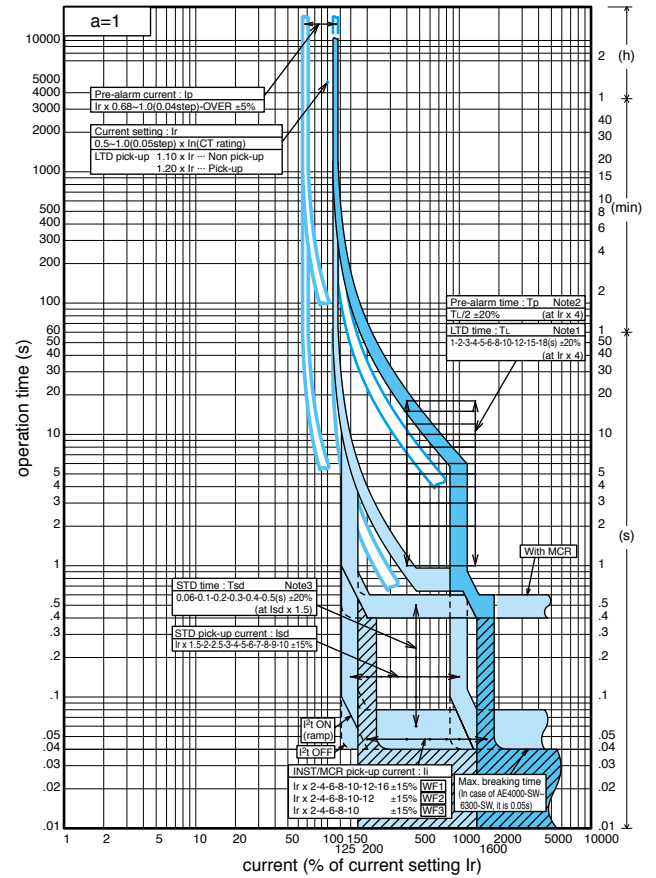

[LTD curve setting "a=3"]

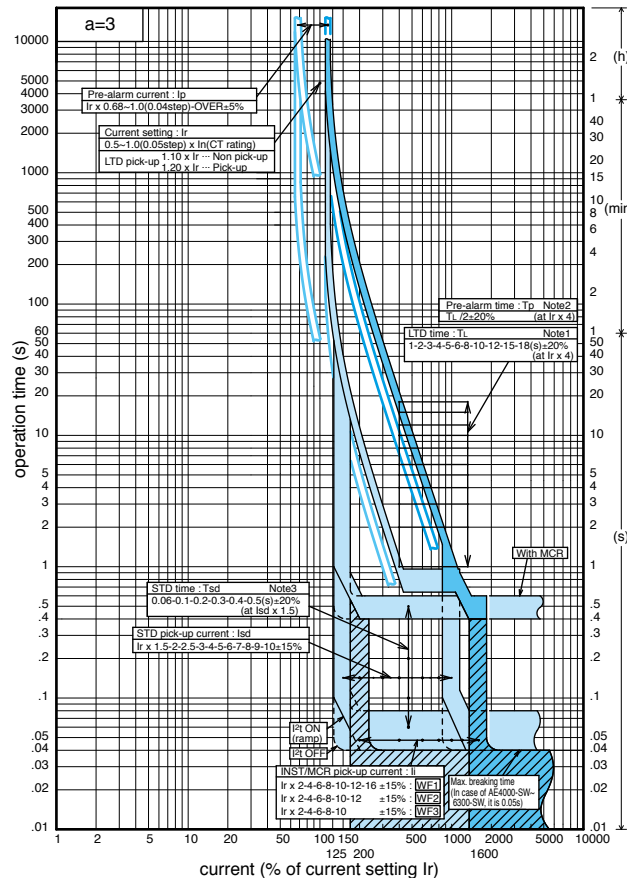

[LTD curve setting "a=4"]

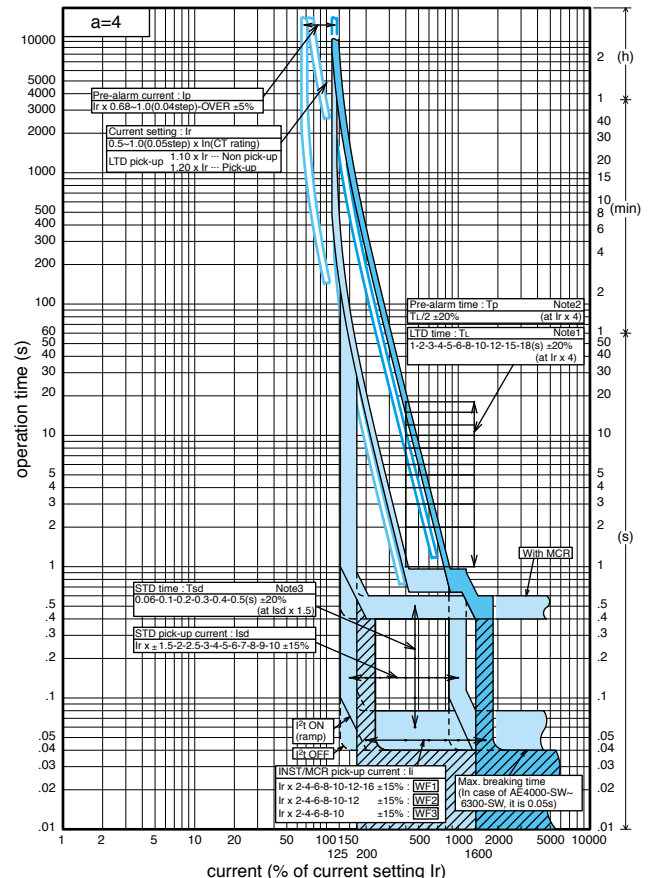

Note 1: LTD operating time  $t_{LTD}$  is calculated by the following equations.

$$t_{LTD} = \frac{(4/1.1155)^a - 1}{(1/1.1155)^a - 1} \times T_L$$

$\begin{cases} a = \text{LTD curve setting} \\ I = \text{load current (A)} \\ I_r = 0.5 - 1.0 \times \ln(A) \\ T_L = 1 - 18 \text{ (s)} \end{cases}$

The accuracy of operating time is  $\pm 30\%$  ( $1.5I_r \leq \text{load current} < 4I_r$ ) or  $\pm 20\%$  ( $4I_r \leq \text{load current}$ ). LTD operating time is 0.8s (FLAT) when the operating time becomes 0.8s or less.

Note 3: When  $T_{sd} = "0.06"$  setting, operating time is 0.04-0.08s.  
It is selectable : ON or OFF.

Note 2: PAL operating time  $t_{PAL}$  is calculated by the following equations.

$$t_{PAL} = \frac{(4/1.971p)^a - 1}{(1/1.971p)^a - 1} \times \frac{T_L}{2}$$

$\begin{cases} a = \text{LTD curve setting} \\ I = \text{load current (A)} \\ I_r = 0.5 - 1.0 \times \ln(A) \\ I_p = (0.68 - 1.15 \times I_r) \text{ (A)} \\ T_L = 1 - 18 \text{ (s)} \end{cases}$

The accuracy of operating time is  $\pm 30\%$  ( $1.5I_r \leq \text{load current} < 4I_r$ ) or  $\pm 20\%$  ( $4I_r \leq \text{load current}$ ). PAL operating time is 0.5s (FLAT) when the operating time becomes 0.5s or less.

# Wiring diagram

● The following diagram shows the case that accessories are fully equipped.

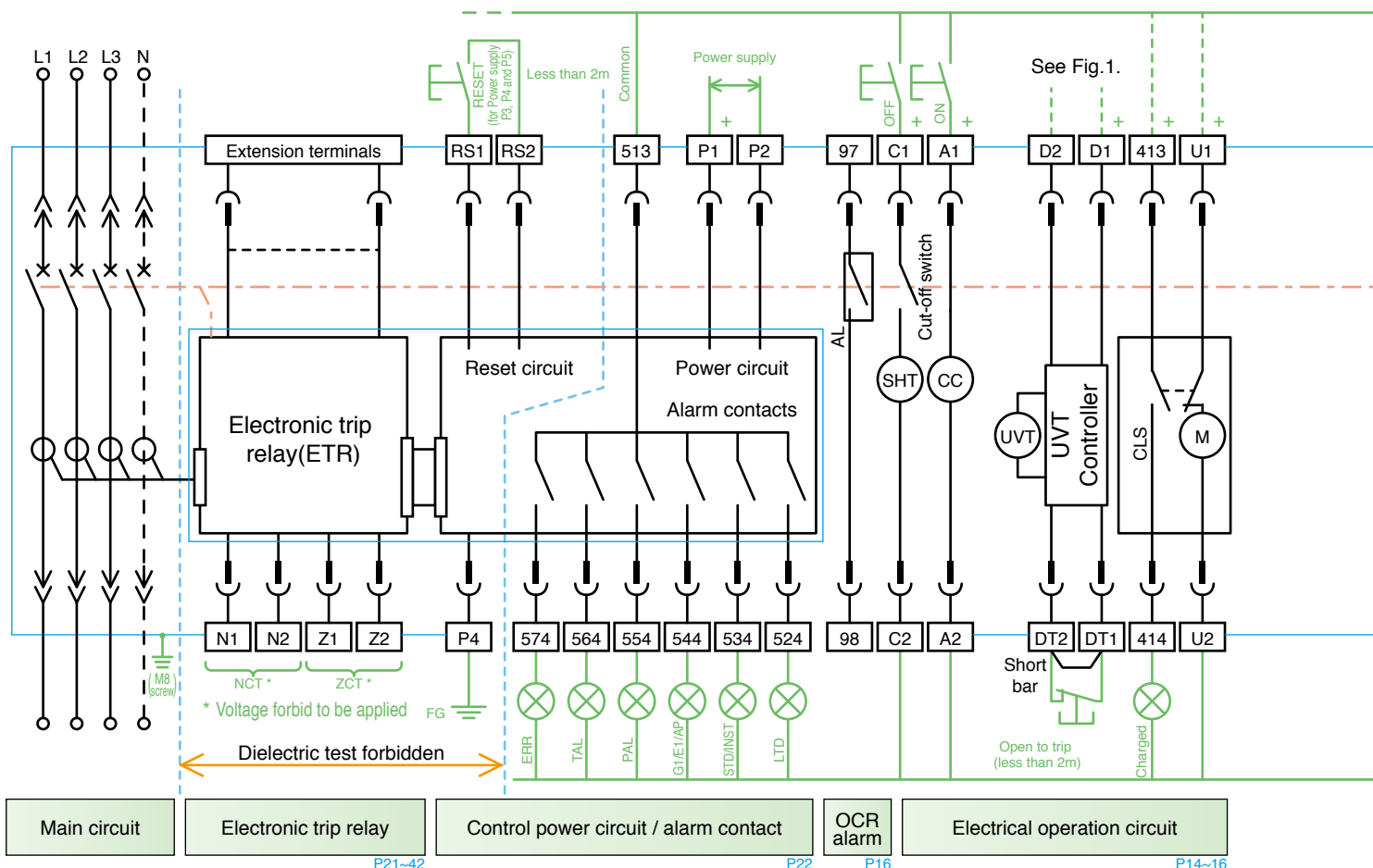

## Terminal description

13	14	~	53	54	Auxiliary switch "a"
11	12	~	51	52	Auxiliary switch "b"
U1	U2				Motor charging
413	414				Charged signal (Normal open)
D1	D2				Voltage Input terminal of UVT
DT1	DT2				Trip terminal of UVT (Remote trip)
A1	A2				Closing coil
C1	C2				Shunt trip
97	98				OCR alarm
P1	P2				Power supply for ETR
P4					FG of power supply (FG:Frame Ground)
RS1	RS2				Alarm reset (Trip cause LED, alarm contact)
513	524				Alarm contact for LTD Trip
513	534				Alarm contact for STD or INST Trips
513	544				Alarm contact for Ground fault, Earth leakage trips or 2nd Pre-alarm contact
513	554				Pre-alarm contact
513	564				Temperature alarm contact
513	574				Error alarm contact
Z1	Z2				For external ZCT
N1	N2				For Neutral CT (Note)
Extension terminals					For external display DP2
					For Interface unit
					For VT unit

## Accessory Symbols

	SHT	Shunt tripping device
	CC	Closing coil
	M	Motor(Motor charging device)
	UVT	UVT coil
	AX	Auxiliary switch
	AL	OCR alarm switch
	CLS	Charge limit switch
	SBC	Shorting b-contact
	CL	Cell switch

— Internal wiring

— External wiring (user's wiring)

— Control circuit connector (drawout type)

### Control circuit terminal block Terminal placement

VT	N1	Z1	RS1	513	564	544	524	P1	97	C1	A1	DT1	D1	413	U1	51	41	31	21	11	53	43	33	23	13
I/F-1	N2	Z2	RS2	P4	574	554	534	P2	98	C2	A2	DT2	D2	414	U2	52	42	32	22	12	54	44	34	24	14

Extended terminal

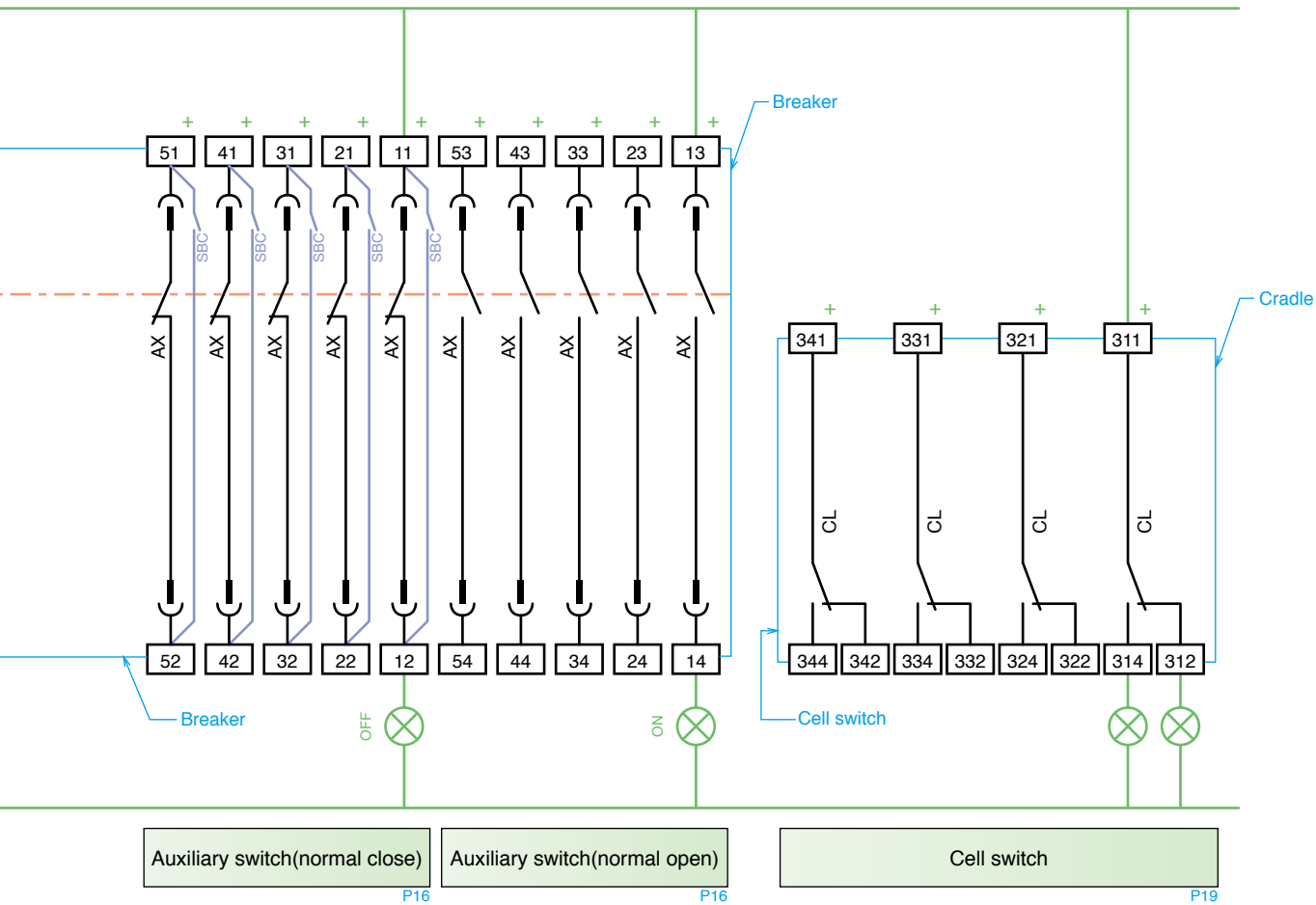
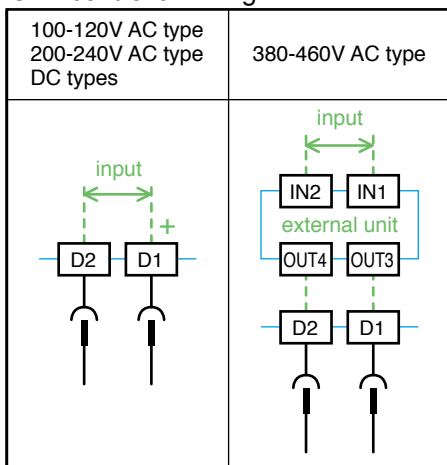
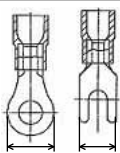

Fig.1  
UVT controller wiring



### Control circuit Recommended crimp-type terminals



for M3.5 screw  
(wire size 1.25mm<sup>2</sup>~2.0mm<sup>2</sup>)

Max. 7.2mm

#### Note;

- For the drawout type, the cables should have the length which allow the control circuit terminal block to be moved to the left or right by 5mm.
- When a coil load is connected in the same control circuit as the ETR, surge absorbers are required to absorb the surge voltage.
- OCR alarm (AL)  
The contact output of the OCR alarm (Standard type AL) is the one-pulse output and the output time is 30~50ms.  
For this reason, this output needs self-holding circuit.
- For Power supply type P3 and P4, the high sensitive relay used in contact output may cause the chattering noise (wrong output of 1ms level) during ON and OFF operation, depending on the Panel placing condition. When it is used in the quick responsive sequence, the filter circuit of a few milli-second (ms) should be provided or the double reading sampling should be implemented.
- Closing coil (CC)  
As CC is one-pulse driven, it is not necessary to insert AXb for burning prevention purposes. Inserting AXb will cause anti-pumping function to be ineffective.
- Under voltage trip device (UVT)  
Use the switch that can open and close 150V DC, 0.5A for remote trip.  
Remote trip terminal has short bar at shipment, so remove it before using this function.  
Disconnect the voltage input wires during dielectric testing of main circuit.
- Since some terminals are polarized, the wiring should be done correctly as the polarity shown in the wiring diagram when the control voltage is DC. Auxiliary switch (AX) Standard type has no polarity.
- Alarm reset (Terminal: [RS1] and [RS2]) is available only for Power supply type P3, P4 and P5.  
For Power supply type P1 and P2, it can not be reset from the Control circuit terminal block ([RS1] and [RS2]).
- Alarm contacts (Terminal : [513]~[574]) are available only for power supply type [P3], [P4] and [P5]. For output contacts, refer to page 22 Note2.
- FG (Terminal: [P4]) is the protective earth for power supply (Terminal: [P1], [P2]).  
It is recommended to use this terminal to reduce surge (M8 screw required).
- Shorting b-contact (SBC)  
SBC can be provided for all AX b contacts. At the time of shipment from factory, SBC is already connected to control circuit terminal block. Only one more crimp terminal can be added on contact, overlapping with SBC's contact on Terminal: [11]~[51].