

## 1. Internal Accessories

The accessories to be installed in circuit breakers include the followings. For the numbers of the accessories which can be installed, refer to the tables on pages 110 to 114. The standard internal accessories have lead wires (450mm in length) drawn out. (However, some of Models UVT and TBM have vertical lead wire terminal blocks as standard.) When circuit breakers are installed side by side, keep a space of 8mm or more for lead wires between the circuit breakers. (Models with lead wires drawn out toward load and models with lead wire grooves in the side faces can be installed in close contact.)

### SHT (Shunt trip)

Device to electrically trip a circuit breaker from a distance. The allowable operating voltage range is 70 to 110% of the rated voltage.

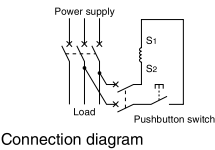

### AL (Alarm switch)

Switch to electrically display the tripping status of circuit breaker.

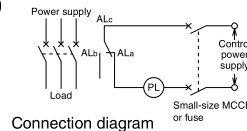

### AX (Auxiliary switch)

Switch to electrically display the ON-OFF status of circuit breaker.

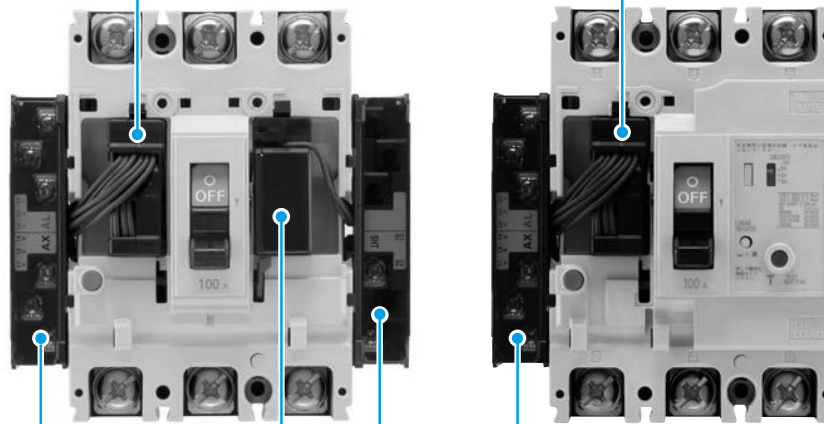
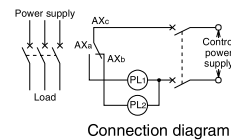

### UVT (Under voltage trip)

Device to automatically trip a circuit breaker when the voltage drops. The operating voltage is 70 to 35% of the UVT rated voltage. When the voltage recovers at least to 85% or more, the circuit breaker can be turned on after the device is manually reset.

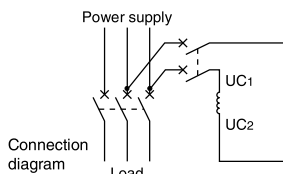

### SLT (Lead wire terminal block)

Terminals for connecting with internal accessories. The terminal block will be manufactured to order. For the detailed dimensions, refer to pages 120 and 121. (The dimensions of SLT slightly vary depending on the number of installed accessories and the model.) However, circuit breakers with a frame size of 400A and above having an electrical operation device are normally provided with SLT.



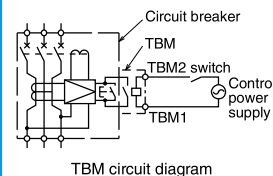

### TBM (Test button module)

Unit to perform test under voltage from a distance. TBMs can be connected in parallel. (The standard TBMs are provided with SLT. In the case of the flush plate type, the external dimensions are partially different from those of the standard type.)





## 2. Terminal Symbols

Table 6-1

| Accessory name                          | Nameplate (sample)  | Accessory name                | Nameplate (sample)  |
|---|---|-------------------------------|---|
| <b>AL</b> Alarm switch                  |  | <b>TBM</b> Test button module |  |
| <b>AX</b> Auxiliary switch              |  |                               |   |
| <b>SHT</b> Shunt tripping device        |  |                               |   |
| <b>UVT</b> Undervoltage tripping device |  |                               |   |

## 3. Operations and Ratings of Switches

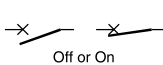
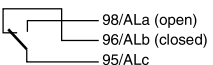
Table 6-2 Operations of AL switch

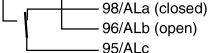
| Status of circuit breaker  | Contact status of AL switch   |
|--|---|
| <br>Off or On |  |
| <br>Trip      |  |

\* The terminal numbers 98/ALa, 96/ALb and 95/ALc may vary depending on the number of installed switches and the installation poles.

Table 6-3 Operations of AX switch

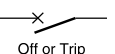
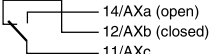
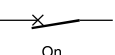
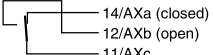
| Status of circuit breaker  | Contact status of AX switch   |
|--|---|
| <br>Off or Trip |  |
| <br>On          |  |

\* The terminal numbers 14/AXa, 12/AXb and 11/AXc may vary depending on the number of installed switches and the installation poles.

Table 6-4 Ratings of AL-AX (Above 400A frame) switches

| Applied switch | AC        |                |                | DC        |                |                |
|----------------|-----------|----------------|----------------|-----------|----------------|----------------|
|                | Voltage V | Current A      |                | Voltage V | Current A      |                |
|                |           | Resistive load | Inductive load |           | Resistive load | Inductive load |
| A              | (250)     | (1)            | (0.5)          | (50)      | (1)            | (0.5)          |
|                | 125       | 3              | (1)            | 30        | 2              | (1)            |
|                | 460       | —              | —              | 250       | 0.2            | 0.2            |
| S              | 250       | 3              | 2              | 125       | 0.4            | 0.4            |
|                | 125       | 5              | 3              | 30        | 4              | 3              |
|                | 460       | 5              | 2              | 250       | 0.3            | 0.3            |
| V              | 250       | 10             | 10             | 125       | 0.6            | 0.6            |
|                | 125       | 10             | 10             | 30        | 10             | 6              |

Remarks: 1. The ratings in parentheses do not conform to UL.  
2. For the applied switches, refer to Tables 6-9 to 6-12-2.

Table 6-5 Ratings of corrosion resist AL and AX switches

| Corrosion resist switch | AC        |                |                | DC        |                |                |
|-------------------------|-----------|----------------|----------------|-----------|----------------|----------------|
|                         | Voltage V | Current A      |                | Voltage V | Current A      |                |
|                         |           | Resistive load | Inductive load |           | Resistive load | Inductive load |
| ST                      | 460       | —              | —              | 250       | 0.2            | 0.2            |
|                         | 250       | 3              | 2              | 125       | 0.4            | 0.4            |
|                         | 125       | 5              | 3              | 30        | 4              | 3              |
| VT                      | 460       | 1              | 0.5            | 250       | 0.3            | 0.3            |
|                         | 250       | 5              | 4              | 125       | 0.4            | 0.4            |
|                         | 125       | 5              | 4              | 30        | 5              | 3              |

Table 6-6 Ratings of small loads AL-AX switches

| Switch | AC        |                |                | DC        |                |                |
|--------|-----------|----------------|----------------|-----------|----------------|----------------|
|        | Voltage V | Current A      |                | Voltage V | Current A      |                |
|        |           | Resistive load | Inductive load |           | Resistive load | Inductive load |
| AB     | 125       | 0.1            | —              | 30        | (0.1)          | —              |
| SB     | 125       | 0.1            | —              | 30        | 0.1            | —              |
| VB     | 125       | 0.1            | —              | 30        | 0.1            | —              |

Remark: 1. Ratings in parentheses are not subject to UL.

## 4. Maximum Number of Internal Accessories

### MCCB and Motor Protection Breakers

Table 6-7 Table of maximum number of internal accessories

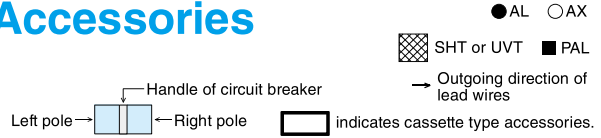

| Model   | C | NF63-CV<br>NF125-CV            | NF63-CV<br>NF125-CV<br>NF250-CV   |                        | NF400-CW<br>NF630-CW                             | NF800-CEW                  |  |
|---|---|--------------------------------|---|------------------------|--|----------------------------|--|
|   | S | NF32-SV<br>NF63-SV<br>NF125-SV | NF32-SV<br>NF63-SV<br>NF125-SV<br>NF125-SGV<br>NF160-SGV<br>NF250-SV<br>NF250-SGV   | NF125-SEV<br>NF250-SEV | NF400-SW<br>NF400-SEW<br>NF630-SW<br>NF630-SEW   | NF800-SEW<br>NF800-SDW     | NF1000-SEW<br>NF1250-SEW<br>NF1600-SEW |
| L<br>•<br>H<br>•<br>R                               |   | NF63-HV                        | NF63-HV<br>NF125-HV<br>NF125-LGV<br>NF125-HGV<br>NF125-RGV<br>NF160-LGV<br>NF160-HGV<br>NF250-HV<br>NF250-LGV<br>NF250-HGV<br>NF250-RGV | NF125-HEV<br>NF250-HEV | NF400-HEW<br>NF400-REW<br>NF630-HEW<br>NF630-REW | NF800-HEW<br>NF800-REW     |  |
|   | U |                                | NF125-UV<br>NF250-UV  |                        | NF400-UEW(3P)                                    | NF400-UEW(4P)<br>NF800-UEW |  |
| HDV<br>HDW<br>HDVA                                  |   | NF63-HDV                       | NF63-HDV(3P)<br>NF125-HDVA(4P)<br>NF250-HDVA(4P)  |                        | NF400-HDW(3P, 4P)                                | NF800-HDW(3P, 4P)          |  |
| Number of poles<br>AL and AX<br>(standard) switches |   | 2 poles                        | 2, 3 or 4 poles   | 3, 4 poles             | 2, 3 or 4 poles                                  | 2, 3 or 4 poles            | 2, 3 or 4 poles                        |
| Accessory   |   | S                              |   |                        |  | V                          |  |
| AL  |   |                                |   |                        |  |                            |  |
| AX  |   |                                |   |                        |  |                            |  |
| SHT or UVT  |   |                                |   |                        |  |                            |  |
| AL + AX   |   |                                |   |                        |  |                            |  |
| SHT + UVT   |   |                                |   |                        |  |                            |  |
| SHT or UVT<br>AL +                                  |   |                                |   |                        |  |                            |  |
| SHT or UVT<br>AX +                                  |   |                                |   |                        |  |                            |  |
| SHT or UVT<br>AL + AX +                             |   |                                |   |                        |  |                            |  |
| PAL<br>(contact output)                             |   |                                |   |                        |  |                            |  |

Notes

- \*1 When UVT is provided, the UVT voltage module will come in the vertical lead wire terminal block type. (SHT does not have a voltage module.)
- \*2 The second AX can be installed in place of the AL on the left pole side. When placing an order, specify the incorporation of the switches in the body.
- \*3 PAL (contact output) can be installed together with AL and AX on the left pole side. (It cannot be installed together with SHT or UVT.) The standard type is provided with SLT. PAL control voltage (compatible with 100 to 200VAC) is necessary.
- \*4 SHT and UVT can be installed on the left side.
- \*5 SHT and UVT are normally installed on the right pole side. If you intend to install them on the left pole side, specify so. (The non-reset type UVT must be installed on the left pole side.)
- \*6 In the case where three or more accessories are installed on the left pole side and AL, AX or AL and AX are installed on the pole on which SLT, SHT or UVT is installed, the SLT will be manufactured to order.
- \*7 When AL, AX or AL and AX are installed on the pole on which UVT is installed, the UVT voltage module must be installed separately.
- \*8 SLT is provided as standard. A control power supply (100 to 200VAC) is required. (In this case, other internal accessories cannot be installed on the right pole side.)

Remarks:

1. For electrically operated automatic reset type circuit breakers having a frame size of 400A or above, the numbers of AL switches which can be installed are smaller by 1 than the values shown above.
2. The encircled numbers indicate the order of installation.
3. AL and AX for minute load can be manufactured to order.

ELCB





















Table 6-8 Table of maximum number of internal accessories

● AL ○ AX ▨ SHT or UVT

Left pole →  ← Right pole

▢ indicates cassette type accessories.

➡ TBM → Outgoing direction of lead wires

| Model                         | C   | NV63-CV<br>NV125-CV<br>NV250-CV   | NV400-CW<br>NV630-CW   |  |
|-------------------------------|---|---|--|--|
|                               | S   | NV32-SV<br>NV63-SV<br>NV125-SV<br>NV125-SEV<br>NV250-SV<br>NV250-SEV                | NV400-SW<br>NV400-SEW<br>NV630-SW<br>NV630-SEW                                       | NV800-SEW  |
| H<br>•<br>R                   | NV63-HV<br>NV125-HV<br>NV125-HEV<br>NV250-HV<br>NV250-HEV                           | NV400-HEW<br>NV630-HEW  |  | NV800-HEW  |
| Number of poles               | 2, 3, or 4 poles  |   | 3 poles  |  |
| Switch                        | S   |   |  |  |
| Accessory                     |   |   |  |  |
| AL                            |    |    |    | <sup>(6)</sup>                                     |
| AX                            |    |    |    | <sup>(6)</sup>                                     |
| AL + AX                       |    |    |    | <sup>(6)</sup>                                     |
| SHT or UVT                    |    |    |    | <sup>(5)</sup>                                     |
| SHT<br>AL +<br>or<br>UVT      |   |  |  | <sup>(4)</sup><br><sup>(5)</sup><br><sup>(6)</sup> |
| SHT<br>AX +<br>or<br>UVT      |   |  |  | <sup>(4)</sup><br><sup>(5)</sup><br><sup>(6)</sup> |
| SHT<br>AL + AX +<br>or<br>UVT |   |  |  | <sup>(4)</sup><br><sup>(5)</sup><br><sup>(6)</sup> |
| TBM                           |  |  |  | <sup>(1)</sup>                                     |

- Notes
- \*1 The standard type is provided with SLT. Only in the case of 24VDC, specify the control voltage.
  - \*2 The second AX can be installed in place of the AL on the left pole side. When placing an order, specify the incorporation of the switches in the body.
  - \*3 When UVT is provided, the UVT voltage module will come in the vertical lead wire terminal block type. (SHT does not have a voltage module.)
  - \*4 When AL, AX or AL and AX are installed on the pole on which UVT is installed, the UVT voltage module must be separately installed.
  - \*5 When the accessory is provided with UVT, the UVT voltage module has a vertical lead wire terminal block. The UVT is not provided with a cassette.
  - \*6 SLT to be used when three or more accessories are installed on the left pole is manufactured to order.
- Remarks:
1. The encircled numbers indicate the order of installation.
  2. TBM can be installed regardless of the number of installed AL, AX, SHT and UVT.
  3. AL and AX for minute load can be manufactured to order.

# 6 Accessories 1 Internal Accessories

## UL Circuit Breakers

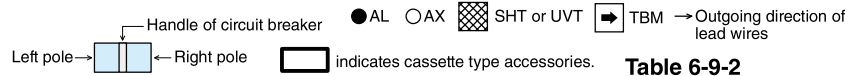

**Table 6-9-1 Table of maximum number of internal accessories**

| Model                | MCCB | NF30-FAU             | NF50-FHU      | NF100-SRU   |                 | NF50-SVFU        | NF50-SVFU      | NF125-SVU           | NF400-SWU           | NF630-SWU           |
|----------------------|------|----------------------|---------------|-------------|-----------------|------------------|----------------|---------------------|---------------------|---------------------|
|                      |      | NF50-FAU             | NF100-FHU(3P) | NF100-HRU   | NF100-HRU       | NF100-CVFU       | NF100-CVFU     | NF125-HVU           | NF250-SVU           | NF400-HWU           |
| Number of poles      |      | 2, 3 poles           | 2, 3 poles    | 2 poles     | 3 poles         | 2 poles          | 3 poles        | 2 or 3 poles        | 3 poles             | 3 poles             |
| Accessory            |      | A                    | S             | A           |                 | S                |                |                     |                     |                     |
| AL                   |      |                      | (*9)          | (*10)       | (*9)            |                  |                |                     |                     | (*4)                |
| AX                   |      |                      | (*9)          | (*10)       | (*9)            |                  |                |                     |                     | (*4)                |
| SHT or UVT           |      | (*8)                 | (*8) (*9)     | (*10) (*11) | (*8) (*9) (*11) | (*1) (*6)        | (*1) (*3) (*6) | (*1) (*3)           | (*1) (*3)           | (*1) (*3)           |
| AL + AX              |      | <br>Only 3 poles     | (*9)          | (*10)       | (*9)            | <br>Only 3 poles | (*2)           | (*2)                | (*6)                | (*6)                |
| AL + SHT or UVT      |      | (*8)<br>Only 3 poles | (*8) (*9)     | (*10) (*11) | (*8) (*9) (*11) | (*1) (*6)        | (*1)           | (*1) (*3) (*4) (*5) | (*1) (*3) (*4) (*5) | (*1) (*3) (*4) (*5) |
| AX + SHT or UVT      |      |                      |               | (*10) (*11) | (*8) (*9) (*11) | (*1) (*6)        | (*1)           | (*1) (*3) (*4) (*5) | (*1) (*3) (*4) (*5) | (*1) (*3) (*4) (*5) |
| AL + AX + SHT or UVT |      |                      |               | (*10) (*11) | (*8) (*9) (*11) | (*1) (*6)        | (*1)           | (*1) (*3) (*4) (*5) | (*1) (*3) (*4) (*5) | (*1) (*3) (*4) (*5) |

**Table 6-9-2 Table of maximum number of accessories**

| Model           | NF | NF50-SMU      |
|-----------------|----|---------------|
|                 |    | NF50-SMU      |
| Number of poles |    | 1, 2, 3 poles |
| Accessory       |    | -             |
| AL              |    |               |
| AX              |    |               |
| SHT             |    |               |
| AL + AX         |    |               |
| AL + SHT        |    |               |
| AX + SHT        |    |               |
| AL + AX + SHT   |    |               |

## 6

## 1 Accessories

| Model                | ELCB | NV30-FAU         | NV50-FHU      | NV100-SRU  |               | NV50-SVFU        | NV125-SVU  |           |
|----------------------|------|------------------|---------------|------------|---------------|------------------|------------|-----------|
|                      |      | NV50-FAU         | NV100-FHU(3P) | NV100-HRU  | NV100-HRU(3P) | NV50-SVFU        | NV100-CVFU | NV125-HVU |
| Number of poles      |      | 2, 3 poles       | 2, 3 poles    | 2, 3 poles | 2, 3 poles    | 2 poles          | 3 poles    | 3 poles   |
| Accessory            |      | A                | S             | A          |               | S                |            |           |
| AL                   |      |                  | (*9)          | (*9)       | (*10)         |                  |            |           |
| AX                   |      |                  | (*9)          | (*9)       | (*10)         |                  |            |           |
| SHT or UVT           |      |                  |               |            |               |                  | (*1) (*6)  | (*1)      |
| AL + AX              |      | <br>Only 3 poles | (*9)          | (*9)       | (*10)         | <br>Only 3 poles | (*2)       | (*2)      |
| AL + SHT or UVT      |      |                  |               | (*9)       | (*10) (*11)   |                  |            |           |
| AX + SHT or UVT      |      |                  |               | (*9)       | (*10) (*11)   |                  |            |           |
| AL + AX + SHT or UVT |      |                  |               | (*9)       | (*10) (*11)   |                  |            |           |
| TBM                  |      |                  |               |            |               |                  | (*7)       | (*7)      |

**Notes**

- \*1 When UVT is provided, the UVT voltage module will come in the vertical lead wire terminal block type. (SHT does not have a voltage module.)
- \*2 SHT cannot be installed.
- \*3 SHT and UVT are normally installed on the right pole side. If you intend to install them on the left pole side, specify so.
- \*4 In the case where three or more accessories are installed on the left pole side and AL, AX or AL and AX are installed on the pole on which SHT or UVT is installed, the SHT or UVT will be manufactured to order.
- \*5 When AL, AX or AL and AX are installed on the pole on which UVT is installed, the UVT voltage module must be installed separately.
- \*6 UVT of NF50-SVFU and NV50-SVFU are not provided with cassettes.
- \*7 The standard type is provided with SLT. Only in the case of 24VDC, specify the control voltage.
- \*8 UVT cannot be installed.
- \*9 Lead drawing is standard. Lead drawing is also available. For NF/NV100-FHU, Lead wires are usually extended load side.
- \*10 Lead drawing is not available.
- \*11 Left pole SHT and UVT are mounted on the side of circuit breaker.

**Remarks:**

1. The encircled numbers indicate the order of installation.
2. AL and AX for minute load can be manufactured to order. (These switches have been certified only by UL and CSA. They have not been certified by TUV.)

## MDU Breakers

**Table 6-10-1 Table of maximum number of internal accessories**

The numbers in ○ indicate the mounting order.

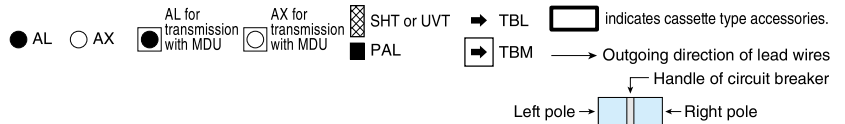

| Model           | NF250-SEV with MDU<br>NF250-HEV with MDU |
|-----------------|--|
| Number of poles | 3, 4 poles                               |
| Switch          | S  |
| AL              | *1                                       |
| AX              | *1                                       |
| AL+AX           | *1 *2                                    |
| SHT             | *1 *3                                    |
|                 | *1 *3                                    |
| UVT             | *4                                       |
| AL+SHT          | *1                                       |
| AX+SHT          | *1                                       |
| AL+AX+SHT       | *1                                       |
| AL+UVT          | *4                                       |
| AX+UVT          | *4                                       |
| AL+AX+UVT       | *4                                       |

| Model                                       | NF250-SEV with MDU<br>NF250-HEV with MDU |
|---|--|
| Number of poles                             | 3, 4 poles                               |
| Switch                                      | S  |
| PAL   | *5<br><small>With PAL contact</small>    |
| AL<br>for transmission with MDU *6          |  |
| AX<br>for transmission with MDU *6          |  |
| AL+AX<br>for transmission with MDU *6       |  |
| AL+AX+AL<br>for transmission with MDU *6    | *1                                       |
| AL+AX+AX<br>for transmission with MDU *6    | *1                                       |
| AL+AX+AL+AX<br>for transmission with MDU *6 | *1                                       |

**Notes:**

- \*1 The right pole SLT specification is built into the main unit (not included with the cassette).  
When MDU specification is "Breaker mounting", "Breaker mounting unit separates".
- \*2. The second AX can be mounted in place of the AL on the left pole side. Please order with the built-in body.
- \*3. Left pole mounting is also possible.
- \*4. The UVT voltage module is a vertical lead wire terminal block type. UVT is not included with the cassette.

| MDU installation type                       | UVT specification   | Remarks   |
|---|---|---|
| Breaker mounting                            | · UVT voltage module separate installation is standard.                                     | Left pole mounting is also possible.<br>(Reset type UVT can not be mounted on the left) |
| Breaker mounting unit separate installation | · In the case of separate display unit, UVT voltage module body mounting is also available. |   |
| External mounting                           | · UVT voltage module body mounting is standard.   |   |
| Panel mounting                              | · A separate UVT voltage module can also be manufactured.                                   |   |

- \*5. It comes with a terminal block specification.  
A control power supply (100-240VAC/DC common) is required (In this case, other internal accessories can not be mounted on the right pole).  
When MDU specification is "Breaker mounting", "Breaker mounting unit separates".
- \*6. When transmitting AL, AX, AL + AX, AL and AX for MDU transmission are left pole mounted.  
In this case, AL and AX for MDU transmission installed on the left pole side can not be used for lead wire extraction and terminal block installation to the outside.

**Remark:**

- 1. AL and AX for minute load can be manufactured to order.



# 6 Accessories 1 Internal Accessories

## MDU Breakers

**Table 6-10-2 Table of maximum number of internal accessories**

The numbers in ○ indicate the mounting order.

| Model           | NF400-SEW with MDU<br>NF400-HEW with MDU | NF800-SEW with MDU<br>NF800-HEW with MDU |
|-----------------|--|--|
| Number of poles | 3, 4 poles                               |  |
| Switch          | S  |  |
| AL              |  | *1                                       |
| AX              |  | *1                                       |
| SHT             | *2                                       |  |
| UVT             | *3 *4                                    |  |
| AL+AX           | *1                                       |  |
| AL+SHT          | *2                                       | *1 *2                                    |
| AX+SHT          | *2                                       | *1 *2                                    |
| AL+AX+SHT       | *1 *2                                    | *1 *2                                    |
| AL+UVT          | *3 *4 *5                                 | *1 *3 *4 *5                              |
| AX+UVT          | *3 *4 *5                                 | *1 *3 *4 *5                              |
| AL+AX+UVT       | *1 *3 *4 *5                              | *1 *3 *4 *5                              |

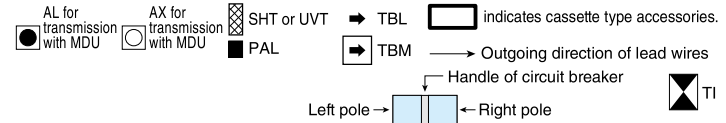

| Model                                    | NF400-SEW with MDU<br>NF400-HEW with MDU | NF800-SEW with MDU<br>NF800-HEW with MDU |
|--|--|--|
| Number of poles                          | 3, 4 poles                               |  |
| Switch                                   | S  |  |
| PAL                                      | *6                                       |  |
| TI                                       | *6<br>With PAL: OAL contact              |  |
| AL for transmission with MDU *7          |  |  |
| AX for transmission with MDU *7          |  |  |
| AL+AX for transmission with MDU *7       |  |  |
| AL+AX+AL for transmission with MDU *7    |  |  |
| AL+AX+AX for transmission with MDU *7    |  |  |
| AL+AX+AL+AX for transmission with MDU *7 |  |  |

- Notes: \*1 When mounting 3 or more accessories on the left pole, SLT is manufactured upon order.  
 \*2 The right pole mounting is standard for SHT. Please specify for left pole installation.  
 \*3 The UVT voltage module is a vertical lead wire terminal block type. UVT is not included with the cassette. With embedded UVT, "UVT voltage module separate" Please specify  
 \*4 UVT is standard with right pole mounting. Please specify for left pole installation. (The reset prevention type UVT has a left pole mounting)  
 \*5 When mounting AL, AX, AL + AX on the same pole as UVT, the UVT voltage module is separate.  
 \*6 It comes with a terminal block specification. Control power supply (100-240VAC/DC shared) 5VA is required.  
 (In this case, other internal accessories can not be mounted on the right pole)  
 \*7 When transmitting AL, AX, AL + AX, AL and AX for MDU transmission are left pole mounted.  
 In this case, AL and AX for MDU transmission installed on the left pole side can not be used for lead extraction and terminal block installation to the outside.

| MDU installation type                       | UVT specification  | Remarks   |
|---|--|---|
| Breaker mounting                            | · UVT voltage module separate installation is standard.<br>· In the case of separate display unit, UVT voltage module body mounting is also available.<br>· UVT voltage module body mounting is standard.<br>· A separate UVT voltage module can also be manufactured. | Left pole mounting is also possible.<br>(Reset type UVT can not be mounted on the left) |
| Breaker mounting unit separate installation |  |   |
| External mounting                           |  |   |
| Panel mounting                              |  |   |

Remark: 1. AL and AX for minute load can be manufactured to order.

## 5. Cassette Type Accessories

The internal accessories for major models having a frame size from 30 to 800A come in cassettes, and they can be installed to and removed from circuit breakers by the user.

Some cassette type accessories have lead wires drawn out, and others have vertical lead wire terminal blocks (SLT). (These parts are supplied by 10 pieces for frame size from 30 to 250A or by 1 piece for frame size from 400 to 800A.)

### ■ Applicable models and kinds of cassette type accessories

|      | Model   | Alarm switch (AL) | Auxiliary switch (AX) | Shunt tripping device (SHT) | Undervoltage tripping device (UVT) |
|------|---|-------------------|-----------------------|-----------------------------|------------------------------------|
| MCCB | NF100-SRU, NF100-HRU<br>NF63-CV~NF250-CV, NF32-SV~NF250-SV<br>NF63-HV~NF250-HV<br>NF125-SGV~NF250-SGV, NF125-LGV~NF250-LGV<br>NF125-HGV~NF250-HGV<br>NF125-SEV, NF250-SEV, NF125-HEV, NF250-HEV<br>NF125-RGV, NF250-RGV, NF125-UV, NF250-UV<br>NF100-CVFU, NF125-SVU/HVU, NF250-CVU/SVU/HVU | ○                 | ○                     | ○                           | ○                                  |
|      | NF50-SVFU, NF400-CW, NF630-CW, NF800-CEW<br>NF400-SW, NF630-SW, NF400-SEW~NF800-SEW<br>NF800-SDW, NF400-HEW~NF800-HEW<br>NF400-REW~NF800-REW, NF400-UEW, NF800-UEW<br>NF400-SWU/HWU, NF630-SWU/HWU  | ○                 | ○                     | ○                           | -                                  |
| ELCB | NV100-SRU, NV100-HRU<br>NV63-CV~NV250-CV, NV32-SV~NV250-SV<br>NV63-HV~HV250-HV<br>NV125-SEV, NV250-SEV, NV125-HEV, NV250-HEV<br>NV100-CVFU, NV125-SVU/HVU, NV250-CVU/SVU/HVU  | ○                 | ○                     | ○                           | ○                                  |
|      | NV50-SVFU, NV400-CW, NV630-CW<br>NV400-SW, NV630-SW, NV400-SEW~NV800-SEW<br>NV400-HEW~NV800-HEW   | ○                 | ○                     | ○                           | -                                  |

### ■ Procedure for installing cassette type accessories



1. Press the trip button (PTT) to trip the circuit breaker. (\*1)



2. Loosen the cover screws.

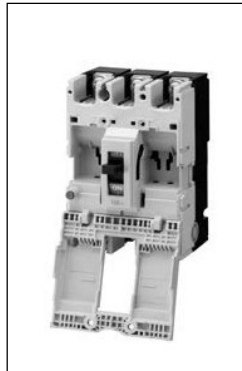

3. Open the cover.

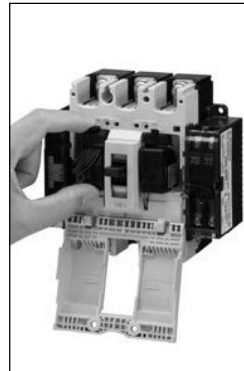

4. Install the cassette type accessory. (\*2)

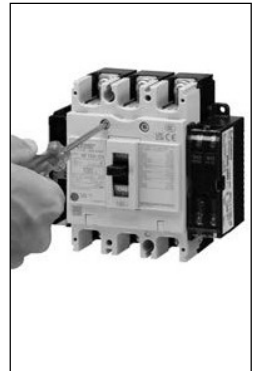

5. Close the cover, and tighten the screws.

Notes \*1. When installing any cassette type accessory, set the circuit breaker to the tripped state.

\*2. If the inner lid or another accessory has been installed, remove it before installing the accessory.

When any circuit breaker supplied with the inner lid is used without an accessory, fit the inner lid without fail.

Failure to do so may affect the short-circuiting performance.

Models with inner lid: NF125-SV, NF125-HV, NF125-UV

NV125-SV, NV125-HV

NF250-SV, NF250-HV, NF250-CVU

NV250-SV, NV250-HV, NV250-CVU

NF125-SVU, NF125-HVU, NV125-SVU, NV125-HVU

NF250-SVU, NF250-HVU, NV250-SVU, NV250-HVU

NF125-SGV~NF250-SGV

NF125-LGV~NF250-LGV

NF125-HGV~NF250-HGV

NF250-SEV, NF250-HEV, NF250-UV

NV250-HEV

NF125-SEV, NF125-HEV

NV125-SEV, NV125-HEV

NF400-REW, NF400-UEW

NF630-REW

NF800-HEW, NF800-REW, NF800-UEW

NV800-HEW

NF630-SWU, NF630-HWU

### Cautions when installing

Before installing or removing any cassette type accessory, set the circuit breaker and accessories to the no-voltage state.

Never install a cassette type accessory while the handle is in the ON or OFF position. Doing so may damage the accessory.

When installing an accessory with lead wires drawn out, apply the supplied nameplate to the circuit breaker side face.

When installing an accessory with lead wires drawn out for a frame size of 400 to 800A, secure the lead wires along the circuit breaker side face with the supplied lead wire retainers.

# 6 Accessories 1 Internal Accessories

## Type name

Table 6-11-1

| Model   |  | Installation pole | AL                               | AX                                 | AL+AX                      | SHT   | UVTN or UVTS  |   |
|---|--|-------------------|----------------------------------|------------------------------------|----------------------------|---|---|---|
| MCCB  | ELCB   |                   |                                  |                                    |                            |   |   |   |
| NF50-SVFU   |  | For right pole    | AL-03SVU<br>AL-03SVURS           | AX-03SVU<br>AX-03SVURS             | ALAX-03SVU<br>ALAX-03SVURS | SHTA240-03SVUR<br>SHTA440-03SVUR<br>SHTD100-03SVUR<br>SHTA240-03SVURS<br>SHTA440-03SVURS<br>SHTD100-03SVURS | -   |   |
|   |  | For left pole     | AL-03SVU<br>AL-03SVULS           | AX-03SVU<br>AX-03SVULS             | ALAX-03SVU<br>ALAX-03SVULS | SHTA240-03SVUL<br>SHTA440-03SVUL<br>SHTD100-03SVUL<br>SHTA240-03SVULS<br>SHTA440-03SVULS<br>SHTD100-03SVULS | -   |   |
| NF32-SV, NF63-CV, NF63-SV, NF63-HV<br>NF125-CV, NF125-SV, NF125-HV<br>NF125-SGV, NF125-LGV, NF125-HGV<br>NF160-SGV, NF160-LGV, NF160-HGV<br>NF125-SEV, NF125-HEV<br>NF125-RGV, NF125-UV<br>NF250-CV, NF250-SV, NF250-HV<br>NF250-SGV, NF250-LGV, NF250-HGV<br>NF250-SEV, NF250-HEV<br>NF250-RGV, NF250-UV |  | For right pole    | AL-05SV<br>AL-05SVRS             | AX-05SV<br>AX-05SVRS               | ALAX-05SV<br>ALAX-05SVRS   | SHTA240-05SVR<br>SHTA550-05SVR<br>SHTD125-05SVR<br>SHTA240-05SVRS<br>SHTA550-05SVRS<br>SHTD125-05SVRS       | UVTNAD130-05SVR<br>UVTNA250-05SVR<br>UVTNA480-05SVR<br>UVTNAD130-05SVRS<br>UVTNA250-05SVRS<br>UVTNA480-05SVRS       | UVTSAD130-05SVR<br>UVTSA250-05SVR<br>UVTSA480-05SVR<br>UVTSAD130-05SVRS<br>UVTSA250-05SVRS<br>UVTSA480-05SVRS       |
|   |  | For left pole     | AL-05SV<br>AL-05SVLS             | AX-05SV<br>AX-05SVLS               | ALAX-05SV<br>ALAX-05SVLS   | SHTA240-05SVL<br>SHTA550-05SVL<br>SHTD125-05SVL<br>SHTA240-05SVLS<br>SHTA550-05SVLS<br>SHTD125-05SVLS       | UVTNAD130-05SVL<br>UVTNA250-05SVL<br>UVTNA480-05SVL<br>UVTNAD130-05SVLS<br>UVTNA250-05SVLS<br>UVTNA480-05SVLS       | UVTSAD130-05SVL<br>UVTSA250-05SVL<br>UVTSA480-05SVL<br>UVTSAD130-05SVLS<br>UVTSA250-05SVLS<br>UVTSA480-05SVLS       |
| NF100-CVFU<br>NF125-SVU/HVU<br>NF250-CVU/SVU/HVU  | NV32-SV, NV63-CV<br>NV63-SV, NV63-HV<br>NV125-CV, NV125-SV<br>NV125-HV<br>NV125-SEV, NV125-HEV<br>NV250-CV, NV250-SV<br>NV250-HV<br>NV250-SEV, NV250-HEV | For right pole    | AL-05SVU<br>AL-05SVURS           | AX-05SVU<br>AX-05SVURS             | ALAX-05SVU<br>ALAX-05SVURS | SHTA240-05SVUR<br>SHTA550-05SVUR<br>SHTD125-05SVUR<br>SHTA240-05SVURS<br>SHTA550-05SVURS<br>SHTD125-05SVURS | UVTNAD130-05SVUR<br>UVTNA250-05SVUR<br>UVTNA480-05SVUR<br>UVTNAD130-05SVURS<br>UVTNA250-05SVURS<br>UVTNA480-05SVURS | UVTSAD130-05SVUR<br>UVTSA250-05SVUR<br>UVTSA480-05SVUR<br>UVTSAD130-05SVURS<br>UVTSA250-05SVURS<br>UVTSA480-05SVURS |
|   |  | For left pole     | AL-05SVU<br>AL-05SVULS           | AX-05SVU<br>AX-05SVULS             | ALAX-05SVU<br>ALAX-05SVULS | SHTA240-05SVUL<br>SHTA550-05SVUL<br>SHTD125-05SVUL<br>SHTA240-05SVULS<br>SHTA550-05SVULS<br>SHTD125-05SVULS | UVTNAD130-05SVUL<br>UVTNA250-05SVUL<br>UVTNA480-05SVUL<br>UVTNAD130-05SVULS<br>UVTNA250-05SVULS<br>UVTNA480-05SVULS | UVTSAD130-05SVUL<br>UVTSA250-05SVUL<br>UVTSA480-05SVUL<br>UVTSAD130-05SVULS<br>UVTSA250-05SVULS<br>UVTSA480-05SVULS |
| NF100-SRU<br>NF100-HRU  |  | For right pole    | AL-05SRU<br>AL-05SRURS           | AX-05SRU<br>AX-05SRURS             | ALAX-05SRU<br>ALAX-05SRURS | SHTA240-05SRU<br>SHTA480-05SRU<br>SHTD125-05SRU<br>SHTA240-05SRURS<br>SHTA480-05SRURS<br>SHTD125-05SRURS    | -   | -   |
|   |  | For left pole     | AL-05SRU<br>AL-05SRULS           | AX-05SRU<br>AX-05SRULS             | ALAX-05SRU<br>ALAX-05SRULS | SHTA110-05SRULS<br>SHTA127-05SRULS<br>SHTA220-05SRULS   | UVTNA110-05SRULS<br>UVTNA127-05SRULS<br>UVTNA220-05SRULS  | -   |
| NF400-CW, NF400-SW, NF400-SEW<br>NF400-HEW, NF400-REW, NF400-UWU<br>NF630-CW, NF630-SW, NF630-SEW<br>NF630-HEW, NF630-REW<br>NF800-CW, NF800-SW, NF800-SEW<br>NF800-HEW, NF800-REW, NF800-UWU   | NV100-SRU<br>NV100-HRU   | For right pole    | -                                | AX-4SW<br>AX-4SWRS<br>AX2-4SWRS    | -                          | SHT-4SW<br>SHT-4SWRS  | -   | -   |
|   |  | For left pole     | -                                | -                                  | -                          | SHT-4SWRFS<br>SHT-8SWRFS  | -   | -   |
| NF400-SWU, NF400-HWU<br>NF630-SWU, NF630-HWU  | NV400-CW, NV400-SW<br>NV400-SEW, NV400-HEW<br>NV630-CW, NV630-SW<br>NV630-SEW, NV630-HEW<br>NV800-CW, NV800-SW<br>NV800-SEW, NV800-HEW                   | For right pole    | AL-4SWL<br>AL-4SWLS<br>AL2-4SWLS | AX-4SW<br>AX-4SWLS<br>AX2-4SWLS    | ALAX-4SWL<br>ALAX-4SWLS    | SHT-4SW<br>SHT-4SWLS  | -   | -   |
|   |  | For left pole     | -                                | AX-4SWU<br>AX-4SWURS<br>AX2-4SWURS | -                          | SHT-4SWU<br>SHT-4SWURS  | -   | -   |
|   |  | For right pole    | AL-4SWU                          | AX-4SWU                            | ALAX-4SWU                  | SHT-4SWU  | -   | -   |

- Remarks:
- For the possibility of installation of accessories and the installation pole, refer to the tables of maximum numbers on pages 110 to 114.
  - AL and AX for minute load can be manufactured to order. (Please specify "B" at the end of the model.)
  - Corrosion-proof cassette type AL and AX are not available. When the circuit breaker body is exposed to class 1 tropicalization, class 2 tropicalization, reinforced corrosion resistance treatment or class 2 heat resistance treatment, place an order for the circuit breaker including the accessories.
  - Cassette type accessories with SLT for right pole cannot be installed to 4-pole circuit breakers. Accessories with SLT for right pole to be used in 4-pole circuit breakers are manufactured to order.
  - Cassette type accessories with SLT cannot be installed to flush plate type circuit breakers.
  - It is impossible to install a combination of a cassette type accessory with lead wires drawn out and that with SLT or a combination of cassette type accessories with SLT on the same pole.
  - It is impossible to install the cassette type AL or AX to the pole to which UVT has been installed.
  - AX and SHT with lead wires drawn out for frame size from 400 to 800A can be installed to any of the right and left poles.
  - When installing more than one AL or AX with lead wires drawn out for frame size from 400 to 800A to one side, install the necessary number of the accessories for one piece. The lead wires from the circuit breaker vary in length depending on the installation position.
  - Install the cassette accessories for frame size from 400 to 800A starting from the outside of the installation positions. For the installation positions, see the installation positions shown in the following table.
  - When three pieces of more of AL and AX are installed on a circuit breaker with a frame size 400 to 800A, the AL and AX with SLT are manufactured to order.

### Installation positions of cassette type accessories for 400 to 800A frames

#### Installation positions

Table 6-11-2 Installation positions of cassette type accessories

| Frame (A) | 400 • 600 • 630        |    |    |    |    | 800 |    |    |    |                  |    |                  |    |
|-----------|------------------------|----|----|----|----|-----|----|----|----|------------------|----|------------------|----|
|           | Installation positions |    |    |    |    | L1  | L2 | L3 | L4 | R4               | R3 | R2               | R1 |
| Accessory | L1                     | L2 | L3 | R2 | R1 | L1  | L2 | L3 | L4 | R4               | R3 | R2               | R1 |
| AL        | ○                      | ○  | -  | -  | -  | ○   | ○  | ○  | -  | -                | -  | -                | -  |
| AX        | ○                      | ○  | -  | ○  | ○  | ○   | ○  | ○  | ○  | -                | -  | ○ <sup>(*)</sup> | ○  |
| AL + AX   | ○                      | ○  | -  | -  | -  | ○   | ○  | -  | -  | -                | -  | -                | -  |
| SHT       | -                      | ○  | -  | ○  | -  | -   | -  | ○  | -  | ○ <sup>(*)</sup> | -  | -                | -  |

\* Accessories only for Earth Leakage Circuit Breakers (NV-C, S and H), Earth Leakage Alarm Breakers (NF-Z) and single-phase 3-wire circuits (NF-N and NV-N) cannot be installed to R1, R2, R3 or R4.  
 Note <sup>(\*)</sup> It is impossible to simultaneously install AX on R2 and SHT on R3 or R4.

Interpretation of type name

(1) Alarm switch • Auxiliary switch

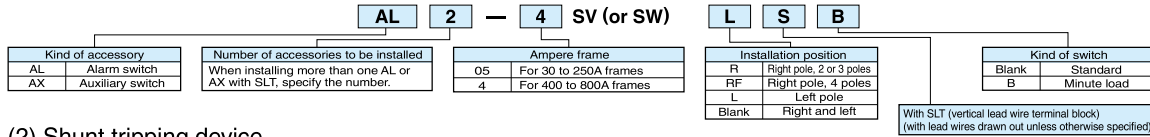

(2) Shunt tripping device

Undervoltage tripping device

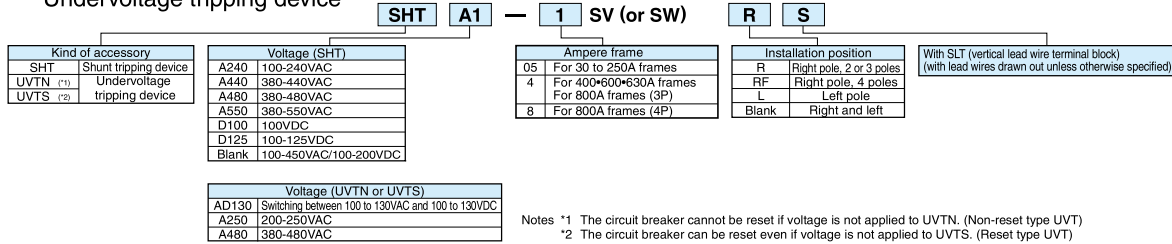

Notes \*1 The circuit breaker cannot be reset if voltage is not applied to UVTN. (Non-reset type UVT)  
\*2 The circuit breaker can be reset even if voltage is not applied to UVTS. (Reset type UVT)

## 6. Shunt Trip (SHT)

### Coil ratings (standard)

Table 6-12-1

| Model   | Provision of coil burnout preventing switch | Voltage (V)   | Input (VA) (1)    |      | Operating time (2) (ms)                    |
|---|---|---|-------------------|------|--|
|   |   |   | AC                | DC   |  |
| NF30-FAU<br>NF50-FAU  | Provided                                    | 100-120VAC<br>200-240VAC  | 120               | —    | 20 or less                                 |
| NF50-FHU<br>NF100-FHU   |   | 100-120VAC<br>200-240VAC<br>100VDC                                    |                   | 50   | 15 or less                                 |
| NF50-SVFU<br>NV50-SVFU  |   | 100-240VAC<br>380-440VAC<br>100VDC                                    |                   | 60   | 15 or less                                 |
| NF32-SV, NF63-CV/SV/HV, NF125-SGV/LGV/HGV<br>NF160-SGV/LGV/HGV, NF125-CV/SV/HV/SEV/HEV/RGV/UV<br>NF250-CV/SV/HV/SEV/HEV/RGV/UV<br>NF250-SGV/LGV/HGV<br>NV32-SV, NV63-CV/SV/HV<br>NV125-CV/SV/HV/SEV/HEV, NV250-CV/SV/HV/SEV/HEV<br>NF100-CVFU, NF125-SVU/HVU, NF250-CVU/SVU/HVU<br>NV100-CVFU, NV125-SVU/HVU, NV250-CVU/SVU/HVU |   | 100-240VAC<br>380-550VAC<br>100-125VDC                                |                   | 50   |  |
| NF100-SRU/HRU (3)   |   | 100-240VAC<br>380-480VAC<br>100-125VDC                                |                   | 5-15 |  |
| NF400-CW/SW/SEW/HEW/REW/UEW<br>NF630-CW/SW/SEW/HEW/REW<br>NF800-CEW/SDW/SEW/HEW/REW/UEW<br>NV400-CW/SW/SEW/HEW<br>NV630-CW/SW/SEW/HEW<br>NV800-SEW/HEW, NF400-SWU/HWU, NF630-SWU/HWU  |   | Compatible with 100 to 450VAC and 100 to 200VDC                       |                   |      | 100V 20<br>200V 50<br>380V 120<br>450V 170 |
| NF100-SRU/HRU<br>NV100-SRU/HRU  | Not provided                                | 100-110VAC, 110-127VAC<br>200-220VAC, 220-240VAC<br>24VDC, 100-110VDC | 10<br>—<br>10     |      | 15 or less                                 |
| NF1000-SEW, NF1250-SEW/SDW<br>NF1600-SEW/SDW  | Provided                                    | 100-120VAC<br>200-240VAC<br>380-450VAC<br>100VDC                      | 200 70<br>300 100 |      | 7-15<br>15-25                              |

Notes \*1 Ensure that the voltage of the operating power supply for SHT is not dropped below the allowable operating voltage (70% of the rated minimum voltage value) by the input power.  
\*2 The operating time is the time from when the rated voltage is applied to the shunt tripping device until the main contact of the circuit breaker starts opening.  
\*3 Available for right pole.

Remark: 1. The accessory is usable at 50 Hz and 60 Hz.

### Coil ratings (list of available special voltage coils)

Table 6-12-2

| Model  | VAC |       |       |    |       |    |         |         |         |         | VDC |    |       |    |       |    |    |     |     |     | Compatible with AC/DC |         |         |
|--|-----|-------|-------|----|-------|----|---------|---------|---------|---------|-----|----|-------|----|-------|----|----|-----|-----|-----|-----------------------|---------|---------|
|  | 24  | 25-27 | 24-48 | 48 | 50-55 | 60 | 440-480 | 380-550 | 440-550 | 500-550 | 12  | 24 | 24-36 | 36 | 36-48 | 48 | 60 | 110 | 125 | 220 |                       | 200-250 | 220-250 |
| NF32-SV, NF63-CV/SV/HV<br>NF125-CV/SV/HV/SEV/HEV/RGV/UV<br>NF125-SGV/LGV/HGV, F160-SGV/LGV/HGV<br>NF250-CV/SV/HV/SEV/HEV/RGV/UV<br>NF250-SGV/LGV/HGV<br>NV32-SV, NV63-CV/SV/HV<br>NV125-CV/SV/HV/SEV/HEV<br>NV250-CV/SV/HV/SEV/HEV<br>NF100-CVFU, NF125-SVU/HVU, NF250-CVU/SVU/HVU<br>NV100-CVFU, NV125-SVU/HVU, NV250-CVU/SVU/HVU | -   | -     | ○     | -  | -     | -  | -       | -       | -       | -       | ○   | -  | ○     | -  | ○     | -  | -  | -   | -   | -   | ○                     | -       | -       |
| NF100-SRU/HRU (1)  | -   | -     | ○     | -  | -     | ○  | -       | -       | -       | -       | ○   | -  | ○     | -  | ○     | -  | -  | -   | -   | -   | -                     | ○       | -       |
| NF400-CW/SW/SEW/HEW/REW/UEW<br>NF630-CW/SW/SEW/HEW/REW<br>NF800-CEW/SDW/SEW/HEW/REW/UEW<br>NV400-CW/SW/SEW/HEW/REW<br>NV630-CW/SW/SEW/HEW<br>NV800-SEW/HEW, NF400-SWU/HWU, NF630-SWU/HWU   | -   | -     | -     | -  | -     | -  | -       | ○       | -       | -       | ○   | -  | -     | -  | -     | -  | -  | -   | -   | -   | -                     | -       | ○       |
| NF1000-SEW, NF1250-SEW/SDW<br>NF1600-SEW/SDW   | ○   | -     | -     | ○  | -     | -  | ○       | -       | -       | ○       | ○   | -  | ○     | -  | ○     | -  | ○  | ○   | ○   | -   | -                     | -       | -       |

Notes \*1 Available for right pole.

## 7. Undervoltage Trip (UVT)

### (1) Specifications for UVT and coil ratings

Table 6-13

| Model   | Specification       |                     | Coil ratings   |   |            |                                    |
|---|---------------------|---------------------|--|---|------------|------------------------------------|
|   | Reset type          | Non-reset type      | Voltage (V)  |   | Input (VA) | Operating time <sup>(2)</sup> (ms) |
|   |                     |                     | Standard voltage   | Special voltage <sup>(1)</sup>  |            |                                    |
| NF50-SVFU<br>NV50-SVFU  | —                   | ○                   |  | 24VAC/DC<br>48VAC/DC  | 5          | 30 or less                         |
| NF32-SV, NF63-CV/SV/HV/HRV<br>NF125-CV/SV/HV/RGV/SEV/HEV/UV<br>NF125-SGV/LGV/HGV, NF160-SGV/LGV/HGV<br>NF250-CV/SV/HV/RGV/SEV/HEV/UV<br>NF250-SGV/LGV/HGV<br>NV32-SV, NV63-CV/SV/HV<br>NV125-CV/SV/HV/SEV/HEV<br>NV250-CV/SV/HV/SEV/HEV<br>NF100-CVFU, NF125-SVU/HVU, NF250-CVU/SVU/HVU<br>NV100-CVFU, NV125-SVU/HVU, NV250-CVU/SVU/HVU | ○                   | ○                   | 100-130VAC/DC<br>200-250VAC<br>380-480VAC  | 24VAC/DC<br>48VAC/DC<br>500-600VAC  |            |                                    |
| NF400-CW/SW/SEW/HEW/REW/JEW<br>NF630-CW/SW/SEW/HEW/REW<br>NF800-CEW/SDW/SEW/HEW/REW/JEW<br>NV400-CW/SW/SEW/HEW<br>NV630-CW/SW/SEW/HEW<br>NV800-SEW/HEW  | ○<br><sup>(4)</sup> | ○<br><sup>(5)</sup> | <sup>(3)</sup><br>Switching between<br>100 to 110 and 120 to 130VAC<br>Switching between<br>200 to 220 and 230 to 250VAC<br>Switching between<br>380 to 415 and 440 to 480VAC<br>Switching between<br>100 and 110VDC | <sup>(3)</sup><br>Switching between<br>24/48VAC<br>Switching between<br>500 to 550/600VAC<br>Switching between<br>24/48VDC<br>Switching between<br>110/125VDC | 5          | 5-30                               |
| NF1000-SEW, NF1250-SEW<br>NF1600-SEW  | ○                   | ○                   |  |   |            | 5-35                               |
| NF400-SWU/HWU, NF630-SWU/HWU  | ○ <sup>(4)</sup>    | —                   |  |   |            | 5-30                               |
| NF100-SRU/HRU, NV100-SRU/HRU  | —                   | ○                   | 100-110VAC<br>110-127VAC<br>200-220VAC<br>220-240VAC<br>24VDC<br>100-110VDC  | —   | 10         | 30 or less                         |

Notes <sup>1</sup> Some special voltage models vary in voltage range.  
<sup>2</sup> The operating time is the time from when the undervoltage tripping device is set to the no-voltage state until the main contact starts opening.  
<sup>3</sup> The accessory is usable at 50Hz and 60Hz.  
<sup>4</sup> If UVT is turned on without excitation, the circuit breaker instantaneously opens and immediately trips.  
<sup>5</sup> Only for installation on the left pole

### (2) Reset type and non-reset type UVT

#### Reset type (Refer to Table 6-15.)

The reset type UVT has a structure which does not trip a circuit breaker even if the UVT coil is not excited when the circuit breaker handle is in the OFF or reset position. Therefore, it keeps the circuit breaker in the reset state even if the coil is not excited when the breaker is reset electrically.

When the coil in the unexcited state is turned on, the circuit breaker is normally tripped. However, the major contacts of some models of circuit breakers may instantaneously close, or, on circuit breakers with AX, the AX switches may instantaneously change over. For electrical interlock, use a non-reset type UVT.

#### Non-reset type (Refer to Table 6-15.)

When the UVT coil is not excited, the circuit breaker cannot be set to the off state even if the circuit breaker is tried to be reset from the tripped state. When the coil exciting voltage restores to the reference voltage or more, the circuit breaker can be reset to the off state.

### (3) Time delay UVT

- This type of UVT has a time delay in operation.
- It can prevent operation upon occurrence of instantaneous power failure.

Table 6-14

| UVT module type name | Time delay                        | Voltage (V)   |   |
|----------------------|-----------------------------------|---|---|
|                      |                                   | Standard voltage  | Special voltage   |
| U-05W                | Switching among 0.1, 0.3 and 0.5s | 24/48AC<br>100-120/200-240/380-450AC<br>220-250/380-450/460-550AC<br>(Compatible with 50Hz and 60Hz)<br>100-110DC | 380-450/460-550/600-690AC<br>(Compatible with 50Hz and 60Hz)<br>24/48DC |
| U-30W                | Switching among 0.5, 1 and 3s     | 100-120/200-240/380-450AC<br>220-250/380-450/460-550AC<br>(Compatible with 50Hz and 60Hz)                         | —   |

Notes <sup>1</sup> Available voltage ranges between 85% of the minimum rated voltage to 110% of the maximum rated voltage for each setting.  
 (Ex.: In the case of 100 to 120V, a voltage range of 85 to 131V is available.)  
<sup>2</sup> The operating time denotes the time from when the UVT is set to the no-voltage state until the main contact of the breaker starts to open.  
<sup>3</sup> Operating time ranges for each setting are as shown below.  
 0.1s setting: 0.1 to 0.3s, 0.3s setting: 0.3 to 0.5s, 0.5s setting: 0.5 to 1.0s, 1.0s setting: 1.0 to 3.0s, 3.0s setting: 3.0 to 6.0s  
<sup>4</sup> The maximum operating time is set by default.  
<sup>5</sup> This value is for the minimum voltage for each rated voltage. (Ex.: 85V or less in the case of 100 to 120V.)  
<sup>6</sup> This value is for the maximum voltage for each rated voltage. (Ex.: 42 to 84V in the case of 100 to 120V.)

Remark <sup>1</sup> Contact us for details on applicable type names and ordering procedures.

### (4) Structure of UVT

The UVT mechanical unit is installed in a circuit breaker, and the UVT voltage module is installed on the outside of the circuit breaker. When the voltage drops, the UVT voltage module detects the voltage drop, and the UVT mechanical unit trips the circuit breaker.

The UVT voltage module has a vertical lead wire terminal block and is normally installed on the body. The external module will be manufactured to order.

#### ●Outline drawing

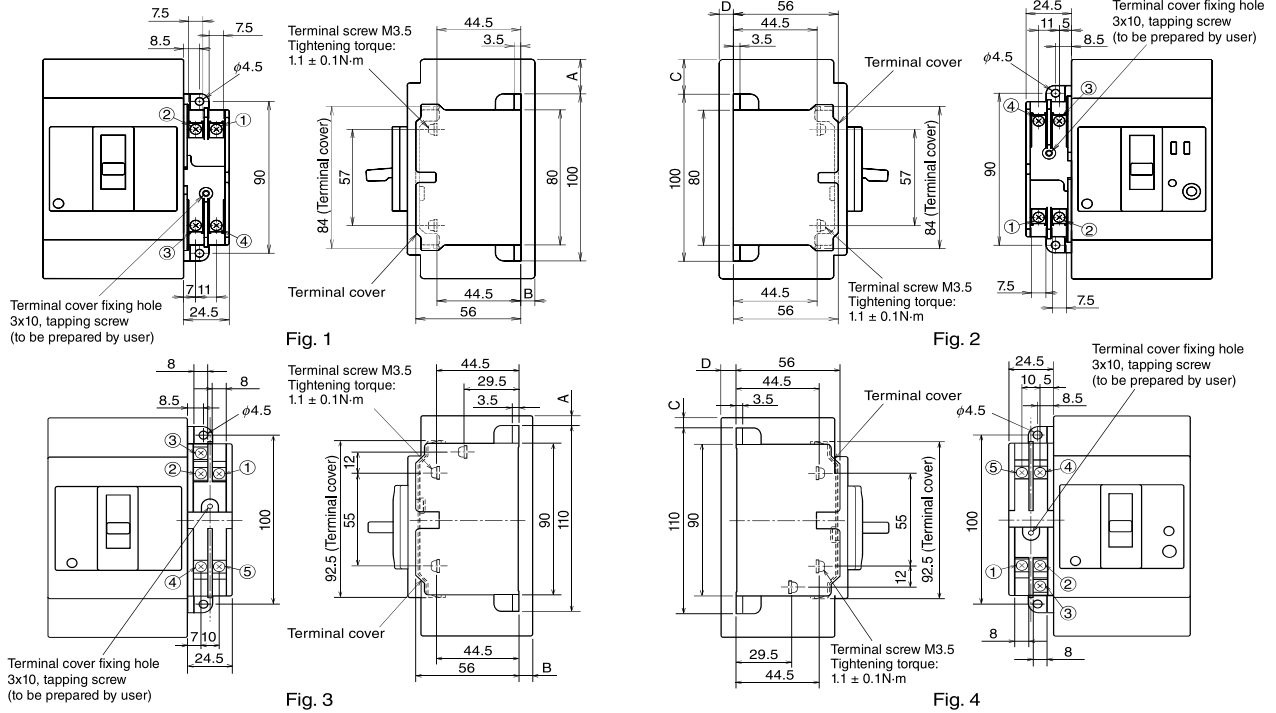

#### ●Examples of connection

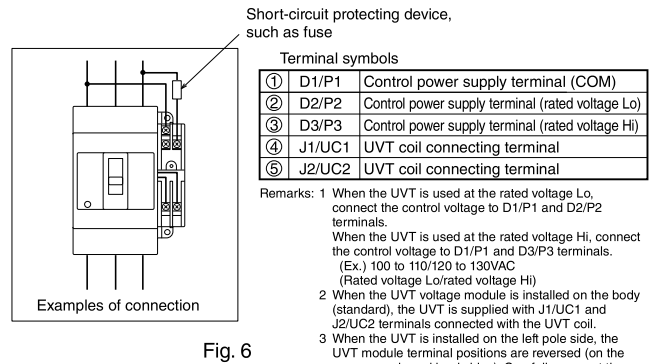
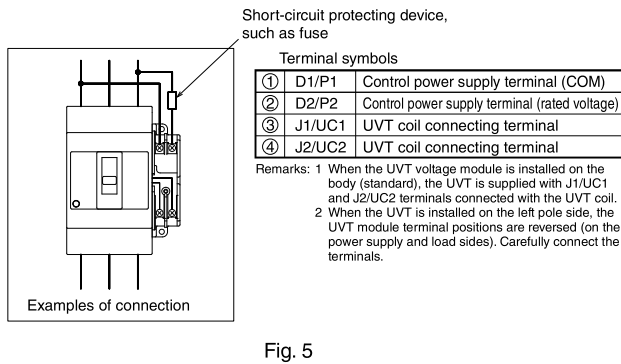

Table 6-15 Installation on right pole side

| Model   | Reference drawing | Variable dimensions (mm) |       |
|---|-------------------|--------------------------|-------|
|   |                   | A                        | B     |
| NF50-SVFU                                     | Fig. 1<br>Fig. 5  | 11                       | 7.5   |
| NF32-SV, NF63-CV/SV/HV                        |                   | 20.5                     | 7.5   |
| NF100-CVFU                                    |                   | 20.5                     | 7.5   |
| NF125-CV/SV/HV                                |                   | 20.5                     | 7.5   |
| NF125-SVU/HVU                                 |                   | 41.5                     | 7.5   |
| NF125-UV                                      |                   | 81.5                     | 7.5   |
| NF125-SEV/HEV/RGV, NF250-CV/SV/HV/RGV/SEV/HEV |                   | 38                       | 7.5   |
| NF125-SGV/LGV/HGV, NF160-SGV/LGV/HGV          |                   |                          |       |
| NF250-SGV/LGV/HGV                             |                   |                          |       |
| NF250-CVU/SVU/HVU                             |                   | 48                       | 7.5   |
| NF250-UV                                      | 113               | 7.5                      |       |
| NF400-CW/SW/SEW/HEW/REW                       | Fig. 3<br>Fig. 6  | 67.5                     | 41.5  |
| NF630-CW/SW/SEW/HEW/REW, NF400-SWU/HWU        |                   | 107.5                    | 138.5 |
| NF400-UW(3P)                                  |                   | 76.5                     | 41.5  |
| NF800-CEW/SDW/SEW/HEW/REW, NF630-SWU/HWU      |                   | 123.5                    | 138.5 |
| NF400-UW(4P), NF800-UW                        |                   | 161                      | 63    |
| NF1000-SEW, NF1250-SEW, NF1600-SEW            |                   |                          |       |

Table 6-16 Installation on left pole side

| Model                                 | Reference drawing | Variable dimensions (mm) |      |      |
|---------------------------------------|-------------------|--------------------------|------|------|
|                                       |                   | C                        | D    |      |
| NV50-SVFU                             | Fig. 2<br>Fig. 5  | 11                       | 7.5  |      |
| NV32-SV, NV63-CV/SV/HV                |                   | 20.5                     | 7.5  |      |
| NV100-CVFU                            |                   | 30.5                     | 7.5  |      |
| NV125-CV/SV/HV                        |                   | 20.5                     | 7.5  |      |
| NV125-SVU/HVU                         |                   | 41.5                     | 7.5  |      |
| NV125-SEV/HEV, NV250-CV/SV/HV/SEV/HEV |                   | 38                       | 7.5  |      |
| NV250-CVU/SVU/HVU                     |                   | 48                       | 7.5  |      |
| NF400-CW/SW/SEW/HEW/REW               |                   | Fig. 4<br>Fig. 6         | 67.5 | 41.5 |
| NF630-CW/SW/SEW/HEW/REW               |                   |                          |      |      |
| NV400-CW/SW/SEW/HEW                   |                   |                          |      |      |
| NV630-CW/SW/SEW/HEW                   |                   |                          |      |      |
| NF400-ZCW/ZSW/ZEW                     |                   |                          |      |      |
| NF400-SWU/HWU                         |                   |                          |      |      |
| NF400-UW(3P)                          |                   |                          |      |      |
| NF800-CEW/SDW/SEW/HEW/REW             | 76.5              | 41.5                     |      |      |
| NV800-SEW/HEW, NF630-SWU/HWU          |                   |                          |      |      |
| NF400-UW(4P), NF800-UW                |                   |                          |      |      |