



Numerical Protection Relay



**MELPRO**™-D Series

FEEDER PROTECTION RELAY

MODEL

**CFP1-A42D1, CFP1-A43D1**

INSTRUCTION MANUAL

■ For the latest version of this instruction manual, please download from the URL below.



<http://www.mitsubishielectric.co.jp/fa/download/search.do?mode=manual&kisyu=/pror>



— Safety precautions —

Before installation, operation, maintenance, and inspection, please be sure to read this instruction manual and all other attached documents thoroughly in order to work safely with the equipment. Please ensure that you fully understand the equipment, safety information, and precautions that need to be taken before working with the equipment.

Safety precautions are classified as “Danger” and “Caution.”

 <b>Danger</b>	The case where a dangerous situation can arise and there is the possibility that death or seriously injury can occur if the equipment is handled incorrectly.
 <b>Caution</b>	The case where a dangerous situation can arise and there is the possibility that moderate or minor injuries can occur, or property damage can take place if the equipment is handled incorrectly.

Furthermore, even with items described as  Caution, there is the possibility of serious consequences depending on the situation. All of the described contents are important. Therefore, be sure to comply with them.

### [Transportation]

 <b>Caution</b>
<ul style="list-style-type: none"><li>● Transport the equipment in the correct orientation.</li><li>● Do not apply excessive shock and/or vibration as this could affect the performance and life of the product.</li></ul>

### [Storage]

 <b>Caution</b>
<ul style="list-style-type: none"><li>● The storage environment shall comply with the following conditions (compliant with JEC2500-2010). Otherwise, there is a risk of reducing the performance and life of the product.<ul style="list-style-type: none"><li>- Ambient temperature                      -20 to +60 °C The state where dew condensation or freezing does not occur.</li><li>- Relative humidity                            30 to 80 % on daily average</li><li>- Altitude    2000 m or lower</li><li>- The equipment must not be exposed to abnormal vibration, shock, inclination, or magnetic fields.</li><li>- The equipment must not be exposed to harmful smoke/gas, saline gas, water droplets or vapour, excessive dust or fine powder, explosive gas or fine powder, wind &amp; rain.</li></ul></li></ul>

### [Installation, wiring work]

 <b>Danger</b>
<ul style="list-style-type: none"><li>● The equipment must be correctly grounded using the designated grounding terminals where they exist. Failure to do so may lead to the risk of electric shock, equipment failure, malfunction or failure to operate.</li><li>● Be sure to return all terminal covers, protection covers to their original positions once any work is complete. If they remain uncovered there is a risk of electrical shock.</li></ul>



### Caution

- Ensure that the equipment is mounted and connected correctly. Otherwise, there are risks of failure, burning, or maloperation..
- Securely tighten the terminal connection screws. Otherwise, there are risks of failure and burning.
- For tightening torque of screws, refer to the following Table.

Place of use	Nominal dia.	Standard value of torque (steel screw)	Allowable range
Terminal block	M3.5	1.10 N•m (11.2 kgf•cm)	0.932 to 1.27 N•m (9.5 to 12.9 kgf•cm)
Panel mounting	M5.0	3.24 N•m (33 kgf•cm)	2.75 to 3.63 N•m (28 to 37 kgf•cm)

- Ensure that the equipment is connected correctly in accordance with the details shown on the connection terminals. Otherwise, there is the risk of failure, burning, malfunction, or maloperation.
- Ensure that the equipment is connected correctly in accordance with the phase sequence details shown on the connection terminals. Otherwise, there is the risk of failure, burning, malfunction, or maloperation.
- All power supplies to the equipment must be of suitable capacity and rated load to avoid the risk of malfunction and maloperation.
- The appropriate connectors must be used to ensure compatibility with the connector terminals to avoid the risks of failure or fire.

## [Operating and Setting the equipment]



### Danger

- The equipment must only be operated and handled by qualified personnel. Otherwise, there are risks of electric shock, injury, failure, malfunction, and maloperation.
- Handling and maintenance of the equipment must only be carried out after gaining a thorough understanding of the instruction manual. Otherwise, there is the risk of electric shock, injury, failure, malfunction, or maloperation.



### Caution

- The equipment must be used within the following range limits (compliant with JEC2500-2010). Otherwise, there is a risk of reducing the performance and life of the product.
  - Variation range of control power supply voltage Within  $-15\%$  to  $+10\%$  of the rated voltage
  - Frequency variation Within  $\pm 5\%$  of the rated frequency
  - Ambient temperature 0 to  $+40^{\circ}\text{C}$   
( $-10$  to  $50^{\circ}\text{C}$  is allowable temporarily within few hours a day, but use under the state where dew condensation or freezing does not occur.)
  - Relative humidity 30 to 80% on daily average
  - Altitude 2000 m or lower
  - The state where abnormal vibration, shock, inclination, magnetic field are not applied
  - The state where it is not exposed to harmful smoke/gas, saline gas, water droplet or vapor, excessive dust or fine powder, explosive gas or fine powder, wind & rain
- While energized, do not tamper with or remove any components other than those which have been designated. Otherwise, there is a risk of failure, malfunction, or maloperation.
- While energized, do not draw out the internal unit (subunit). Otherwise, there is a risk of electric shock, injury, failure, malfunction, or maloperation.
- When changing the setting value during the energized state, ensure that all trip circuits are locked in order not to operate. Otherwise, there is a risk of malfunction.

## [Maintenance and Inspection]

 <b>Danger</b>
<ul style="list-style-type: none"> <li>●The equipment must only be operated and handled by qualified personnel. Otherwise, there are risks of electric shock, injury, failure, malfunction, and maloperation.</li> <li>●Handling and maintenance of the equipment must only be carried out after gaining a thorough understanding of the instruction manual. Otherwise, there is the risk of electric shock, injury, failure, malfunction, or maloperation.</li> <li>●Do not touch any live parts, such as terminals, etc. Otherwise, there is a risk of electric shock.</li> </ul>

 <b>Caution</b>
<ul style="list-style-type: none"> <li>●When replacing the equipment, use a product of same model, rating, and specifications. Otherwise, there is the risk of failure or fire.. If any other product is to be used, the manufacturer must be consulted.</li> <li>●We recommend that any tests or inspections are carried out under the following conditions, as well as any additional conditions described in the instruction manual. <ul style="list-style-type: none"> <li>• Ambient temperature 20 ± 10°C</li> <li>• Relative humidity 90% or less</li> <li>• External magnetic field 80 A/m or less</li> <li>• Atmospheric pressure 86 to 106 × 10<sup>3</sup> Pa</li> <li>• Mounting angle Regular direction ±2°</li> <li>• Frequency Rated frequency ±1%</li> <li>• Waveform (in the case of AC) Distortion factor 2% or less  <math display="block">\text{Distortion factor} = \frac{\text{Effective value of higher harmonics only}}{\text{Effective value of fundamental wave}} \times 100 (\%)</math> </li> <li>• AC component (in the case of DC) Ripple factor 3% or less  <math display="block">\text{Ripple factor} = \frac{\text{Max. value} - \text{Min. value}}{\text{Average value of DC}} \times 100 (\%)</math> </li> <li>• Control power supply voltage Rated voltage ±2%</li> </ul> </li> <li>●Do not exceed the overload capacity for voltage and current. Otherwise, equipment failure or fire could occur.</li> <li>●Do not clean the equipment while energised. When the cover needs to be cleaned, make use of a damp cloth.</li> </ul>

## [Repair and modification]

 <b>Caution</b>
<ul style="list-style-type: none"> <li>●When carrying out repair and/or modification, please consult with the manufacturer in advance.of carrying out the work. We will not take any responsibility for any repair and/or modification (including software) which has been carried out without prior consent.</li> </ul>

## [Disposal]

 <b>Caution</b>
<ul style="list-style-type: none"> <li>●Disposal must take place in accordance with the applicable legislation</li> </ul>

# Guarantee

## 1. Guarantee period

The guarantee period of this product should be one year after delivery, unless otherwise specified by both parties.

## 2. Scope of guarantee

When any fault or defect is detected during the period of guarantee and such fault or defect is proved to be caused apparently at the responsibility of MITSUBISHI ELECTRIC CORPORATION, the defective unit concerned will be repaired or replaced with substitute with free of charge.

However, the fee for our engineer dispatching to site has to be covered by the user.

Also, site retesting or trial operation caused along with replacing the defect units should be out of scope of our responsibilities.

It is to be acknowledged that the following faults and defects should be out of this guarantee.

(1) When the faults or defects are resulted from the use of the equipment at the range exceeding the condition/environment requirements stated in the catalogue and manual.

(2) When the faults or defects are resulted from the reason concerning without our products.

(3) When the faults or defects are resulted from the modification or repair carried out by any other entity than MITSUBISHI ELECTRIC CORPORATION.

(4) When the faults or defects are resulted from a phenomenon which cannot be predicted with the science and technology put into practical use at the time of purchase or contract

(5) In case of integrating our products into your equipment, when damages can be hedged by the proper function or structure in the possession of your equipment which should be completed according to the concept of the de fact standard of industry.

(6) In case of that the faults or defects are resulted from un-proper application being out of instruction of MITSUBISHI ELECTRIC CORPORATION.

(7) In case that the faults or defects are resulted from force majeure such a fire or abnormal voltage and as an act of God such as natural calamity or disaster.

## 3. Exclusion of loss in opportunity and secondary loss from warranty liability

Regardless of the gratis warranty term, MITSUBISHI ELECTRIC CORPORATION shall not be liable for compensation of damages caused by any cause found not be the responsibility of MITSUBISHI ELECTRIC CORPORATION, loss in opportunity, lost profits incurred to the user by failures of MITSUBISHI ELECTRIC CORPORATION products, special damages and secondary damages whether foreseeable or not, compensation for accidents, and compensation for damages to products other than MITSUBISHI ELECTRIC CORPORATION products and other tasks.

## 4. Applications of products

(1) The user is requested to confirm the standards, the regulations and the restrictions which should be applied, in case of utilizing products described in this catalogue and another one in combination.

Also, the user is requested to confirm the suitability of our products to your applied system or equipment or apparatus by yourself.

MITSUBISHI ELECTRIC CORPORATION shall not be liable for any suitability of our products to your utilization.

(2) This MITSUBISHI ELECTRIC CORPORATION products described in the catalogue have been designed and manufactured for application in general industries, etc. Thus, application in which the life or an asset could be affected by special application such as medical system for life-sustaining, in nuclear power plants, power plants, aerospace, transportation devices(automobile, train, ship, etc.) shall be excluded from the application. In addition to above, application in which the life or an asset could be affected by potentially chemical contamination or electrical interference and also in which the circumstances and condition are not mentioned in this catalogue shall be excluded from the application.

Note even if the user wants to use for these applications with user's responsibility, the user to be requested to approve the specification of MITSUBISHI ELECTRIC CORPORATION products and to contact to the technical section of MITSUBISHI ELECTRIC CORPORATION prior to such applications.

If the user applies MITSUBISHI ELECTRIC CORPORATION products to such applications without any contact to our technical section, MITSUBISHI ELECTRIC CORPORATION shall not be liable for any items and not be insured, independently from mentioned in this clause.

(3) In using MITSUBISHI ELECTRIC CORPORATION product, the working conditions shall be that the application will not lead to a major accident even if any problem or fault occur, and that backup or duplicate system built in externally which should be decided depend on the importance of facility, is recommended.

(4) The application examples given in this catalogue are reference only and you are requested to confirm function and precaution for equipment and apparatus and then, use our products.

(5) The user is requested to understand and to respect completely all warning and caution items so that unexpected damages of the user or the third party arising out of un-correct application of our products would not be resulted.

5. Onerous repair term after discontinuation of product

(1) MITSUBISHI ELECTRIC CORPORATION shall accept onerous product repairs for 7(seven) years after production of the product is discontinued. (However, please consider the replacement of products after 15 years have been passed from ex-work of products.)

(2)Product supply (including repair parts) is not available after production is discontinued.

6. Changes in product specification

The specification given in the catalogue, manuals or technical documents are subject to change without prior to notice.

7. Scope of service

The technical service fee such as engineer dispatching fee is excluded in the price of our products.

Please contact to our agents if you have such a requirement.

## Improvement on the reliability of protection function

Any parts and materials applied to the protection relay have limited life time which will bring the degradation to the relay.

The degree of degradation will be variable and depend on the purpose, period in use, applied circumstance and unevenness on the performance of each part.

MITSUBISHI ELECTRIC CORPORATION design the relay so as to realize that the recommended replaced duration is more than 15 years.

However, there may be some possibilities to occur some defects before reaching 15 years due to above mentioned the degree of degradation of parts and materials being depended on the condition in use.

To prevent unwanted operation or no operation of relay due to above reasons, it is recommended to apply the relay with self-diagnosis function and/or multiplexing relay system such as dual or duplex scheme.

## Introduction

Thank for your purchasing MITSUBISHI ELECTRIC **MELPRO**<sup>™</sup> – D Series Digital Protection Relay.  
Please read this instruction manual carefully to be familiar with the functions and performances enough to use the product properly.

It is necessary to forward this instruction manual to end users and a person in charge of maintenance.

In regard to the instruction manual for PC software, read the following document.

Title of document	Document No.
MELPRO-D Series Protection Relay PC-HMI Instruction Manual	JEP0-IL9504

## INDEX

<b>1.</b>	<b>General description .....</b>	<b>10</b>
<b>2.</b>	<b>Structure .....</b>	<b>11</b>
2.1.	Front view of relay .....	11
2.2.	Terminal layout on the back of relay .....	12
2.3.	Dimensions of relay and Cut-Out dimensions of panel .....	13
2.4.	External view of relay .....	14
<b>3.</b>	<b>Handling, Mounting.....</b>	<b>15</b>
3.1.	Unpacking .....	15
3.2.	Transportation and storage .....	15
3.3.	How to draw sub-unit out.....	15
3.3.1.	Procedures for drawing out subunit.....	16
3.3.2.	Procedures for housing subunit.....	16
3.4.	Mounting.....	17
3.5.	Distance between two devices .....	17
<b>4.</b>	<b>Connection .....</b>	<b>18</b>
4.1.	Precautions for wiring work .....	18
4.2.	Terminal layout.....	19
4.3.	External connection .....	20
4.3.1.	Connection example of control circuit.....	20
4.3.2.	Connection example of input circuit.....	20
<b>5.</b>	<b>Human machine interface .....</b>	<b>22</b>
5.1.	Pushbutton switches and indication display .....	22
5.2.	List of menus.....	26
5.3.	Operation method.....	27
5.3.1.	DISPLAY/SETTING mode selection.....	27
5.3.2.	DISPLAY mode menu operations.....	28
5.3.2.1.	Status (STATUS) menu.....	29
5.3.2.1.1.	Clock (CLOCK) menu.....	30
5.3.2.1.2.	Measured analog value (METERING) menu .....	31
5.3.2.1.3.	DI/DO status (DIGITAL I/O) menu .....	33
5.3.2.1.4.	Trip counter (TRIP COUNTER) menu .....	34
5.3.2.1.5.	Device name (DEVICE NAME) menu.....	34
5.3.2.2.	Record (RECORD) menu .....	35
5.3.2.2.1.	Fault record (FAULT RECORD) menu .....	36
5.3.2.2.2.	Event record (EVENT RECORD) menu .....	40
5.3.2.2.3.	Access record (ACCESS RECORD) menu .....	43
5.3.2.2.4.	Alarm record (ALARM RECORD) menu.....	45
5.3.2.3.	Setting (SETTING) menu .....	46
5.3.2.4.	Configuration (CONFIG) menu.....	46
5.3.3.	Password input screen .....	47
5.3.4.	SETTING mode menu operations .....	48
5.3.4.1.	Setting (SETTING) menu .....	49
5.3.4.1.1.	Active group (ACTIVE WG) menu .....	50
5.3.4.1.2.	Group 1 setting (G1) and Group 2 setting (G2) menus.....	51
5.3.4.2.	Configuration (CONFIG) menu.....	54
5.3.4.2.1.	Communication setting (COMMUNICATION) menu.....	55
5.3.4.2.2.	Clock adjustment (CLOCK ADJUST) menu .....	56
5.3.4.2.3.	Analog value display switching (METERING) menu.....	58
5.3.4.2.4.	Trip counter (TRIP COUNTER) menu .....	60
5.3.4.2.5.	Disturbance record (DISTURBANCE) menu .....	61
5.3.4.2.6.	Password use/unuse (PASSWORD USE) menu.....	62

5.3.4.2.7. Password registration (PASSWORD REGIST) menu.....	63
5.3.4.3. TEST menu .....	64
5.3.4.3.1. DO contact test (CONTACT TEST) menu .....	64
5.3.4.3.2. Test mode (MODE) menu .....	66
5.3.4.3.3. LED/VFD lighting test (LED/VFD TEST) menu.....	67
5.3.4.4. Clear record (RECORD-CLR) menu.....	68
5.3.4.4.1. Clear fault record (FAULT REC CLEAR) menu.....	68
5.3.4.4.2. Clear alarm record (ALARM REC CLEAR) menu.....	69
5.3.4.4.3. Clear event record (EVENT REC CLEAR) menu .....	69
<b>6. PC-HMI .....</b>	<b>70</b>
<b>7. Rating, Specification.....</b>	<b>75</b>
7.1. Features .....	75
7.2. Standard Ratings.....	76
7.3. Protection elements.....	77
7.4. Measuring element .....	78
7.5. List of functions.....	79
<b>8. Protective function .....</b>	<b>80</b>
8.1. Overcurrent element.....	81
8.1.1. OC1 element (Instantaneous Overcurrent element).....	82
8.1.2. OC2 element (Instantaneous overcurrent element with 2 <sup>nd</sup> harmonic restraint) .....	83
8.1.2.1. 2 <sup>nd</sup> harmonic restraint function.....	84
8.1.3. OC3 element (Instantaneous overcurrent element with 2 <sup>nd</sup> harmonic restraint).....	85
8.1.4. OC4 element (Definite time or IDMT overcurrent with 2 <sup>nd</sup> harmonic restraint).....	86
8.1.4.1. Operating time characteristic .....	88
8.1.4.2. Reset time characteristic .....	89
8.1.4.3. IDMT characteristic.....	91
8.2. Directional ground (earth) fault element .....	109
8.2.1. DIRG1 element.....	110
8.2.2. DIRG2 element.....	112
<b>9. Standard (Technical data) .....</b>	<b>114</b>
9.1. Relay characteristic data .....	114
9.2. General specification data .....	120
<b>10. Test.....</b>	<b>124</b>
10.1. Visual inspection.....	124
10.2. Characteristic test.....	125
10.2.1. Notes related to the tests.....	125
10.2.2. Characteristic test.....	126
<b>11. Maintenance and self diagnosis .....</b>	<b>128</b>
11.1. Maintenance.....	128
11.1.1. Daily inspection .....	128
11.1.2. Periodic inspection .....	128
11.2. Self diagnosis .....	129
<b>12. Default setting or configuration value .....</b>	<b>132</b>
12.1. Setting .....	132
12.2. Output contacts .....	134

# 1. General description

Mitsubishi Electric **MELPRO™** – D Series is a digital protection relay product with a microprocessor for protection of high/extra-high voltage electric power systems.

With its improved functions, such as PLC (Programmable Logic Controller), data saving at the time when relay elements are operated, and measurement of input value, this series of protection relay allows stable and effective control and monitoring of electric power systems as well as high-reliable protection.

## High accurate digital computation

The digital computation with high-speed sampling minimizes the effect of higher harmonics, etc., which enables high accurate protections. As this computation is implemented in software, stable operation without aging is obtained.

## Advanced self-diagnosis function improves reliability

The relay continuously monitors electronic circuits from input to output so that it can detect internal component failure, which enables to improve reliability.

## Measurement functions

The input values of the relay (e.g. current, voltage, phase and frequency) can be measured at a steady state, which is useful for energy-saving management. Measurement items differ depending on the types of the relay units.

## Data saving functions

Various record functions as shown below are useful for fault investigations.

- (1) The data savings of input value at the time when relay element are operated.
- (2) The operation logs of the relay.

## Programmable output contacts with PLC provide flexibility

The operation of output contacts can be set by combining the detection or definitive signals of the protection elements with PLC which incorporates logic circuit (e.g. OR, AND, NOT, and flip-flop) and timer (e.g. on-delay, off-delay, and one-shot). This is useful for easy designing of sequential circuits and reducing labor-hours of wiring.

## Forced contact test enables checking of relay sequence

The output contacts can be forced to operate in the test menu, which enables checking of relay sequence easily.

## Easy replacement

The cut-out dimensions of panel are the same as MULTICAP-C series or the old model of MELPRO-DASH series. Replacing an existing relay with this new type is easy. (There are some exceptions.)

## Easy maintenance

The relay adopts draw-out unit mechanisms with automatic CT shorting at drawing, thereby making it easy to maintain the relay.

## Diverse operation and reset characteristics

The relay incorporates various operation and reset characteristics including the standards of IEC 60255-3, which can be adopted to the protection of various types of electric systems.

## Communication network (will be supported in the future)

The relay can build a network system which allows monitoring and control of measurement values, operation status, and setting changes, etc., from a remote location. This leads to labor-saving of maintenance.

## 2. Structure

### 2.1. Front view of relay

For the details about front panel, refer to Section 5.1.

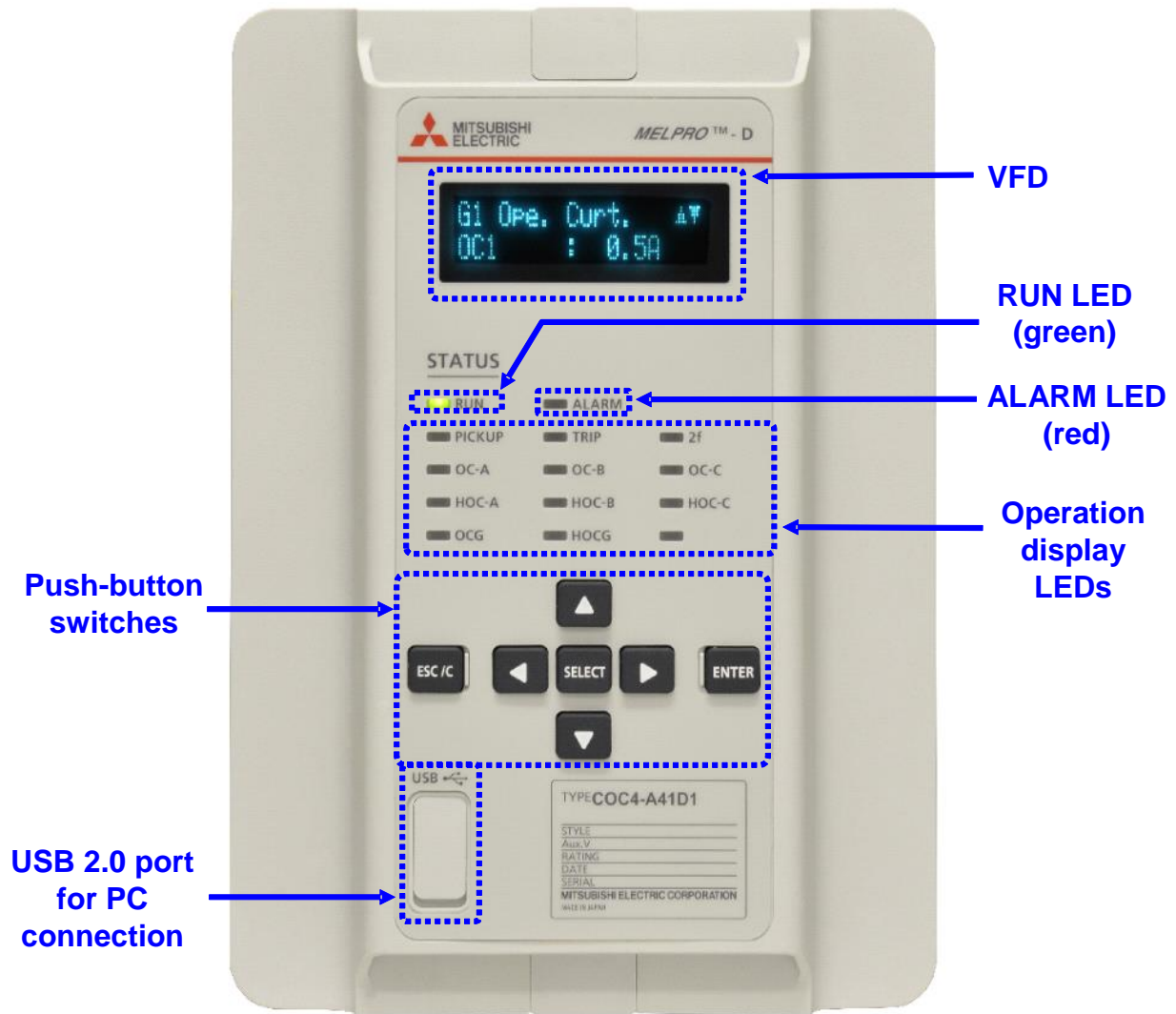

Fig. 2-1 Front view of relay



### 2.3. Dimensions of relay and Cut-Out dimensions of panel

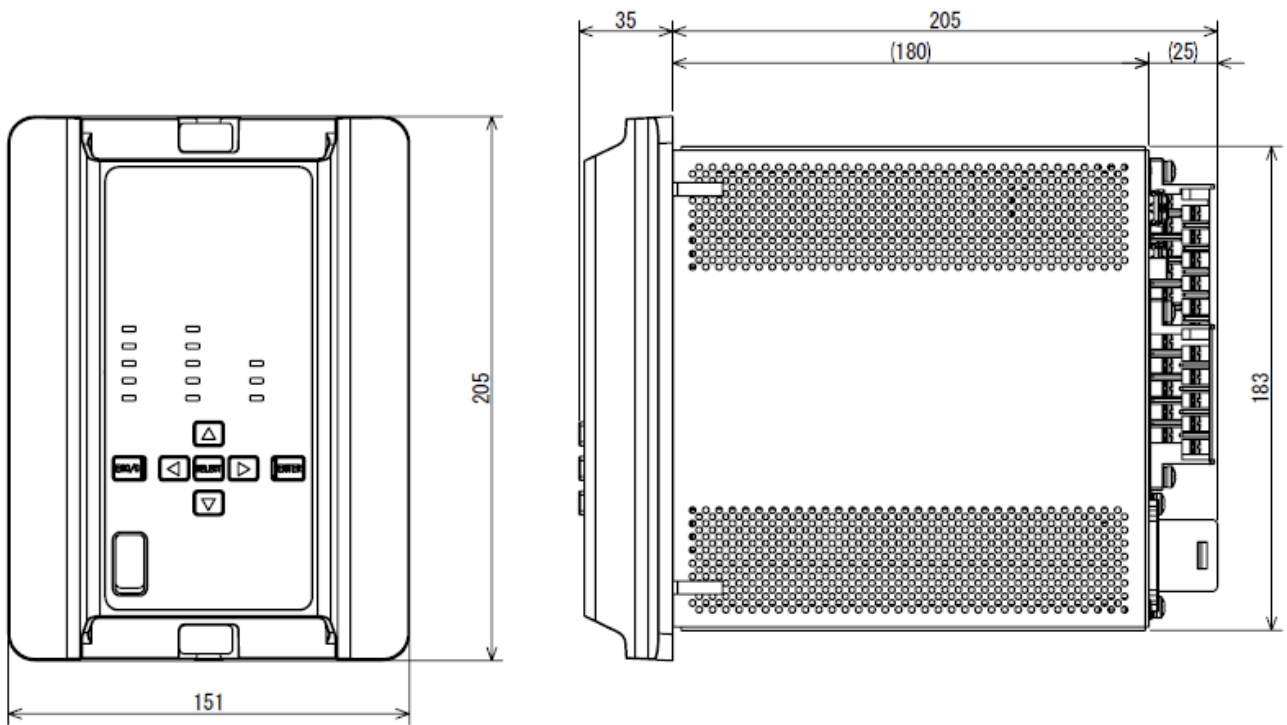

Fig. 2-4 Dimensions of relay

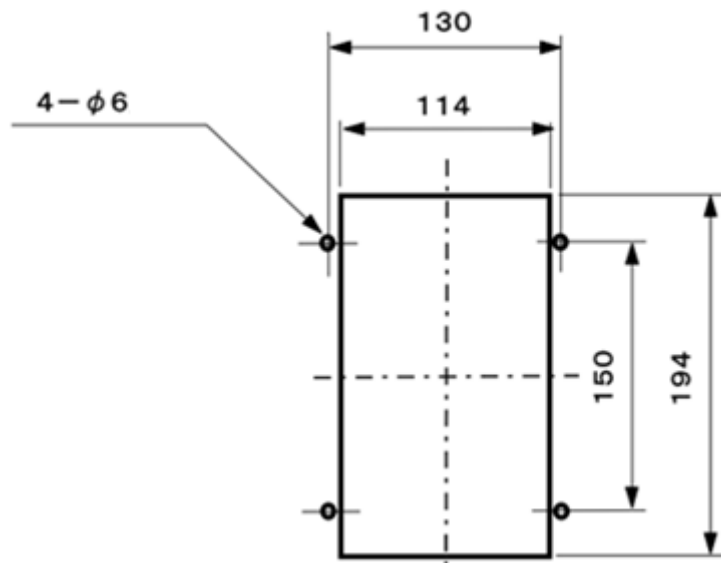
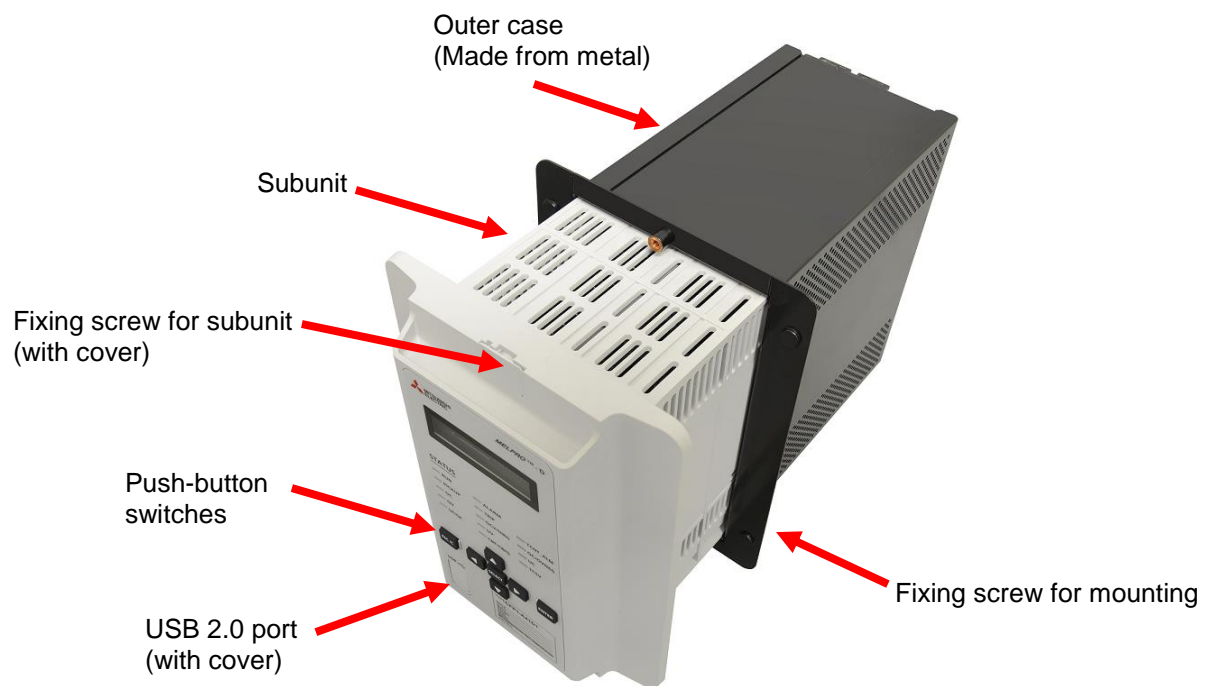

Fig. 2-5 Cut-Out dimensions of panel

## 2.4. External view of relay



**Fig. 2-6 External view of relay**

## 3. Handling, Mounting

### 3.1. Unpacking

Usually this relay is packed in a case for transportation. However, it may occur that only the sub-unit is transported independently for the convenience at repair. In such a case, fully brush off the dust, dirt, etc. adhered to the sub unit after completion of unpacking, and further visually check that the parts mounted on the front panel or built in the sub unit are not damaged.

### 3.2. Transportation and storage

To carry the equipment within the place of use, handle it carefully so that the parts installed on the front panel of the sub-unit or built-in parts cannot be deformed or broken.

### 3.3. How to draw sub-unit out

The relay has draw-out construction to facilitate inspection and testing. Therefore, it is possible to draw out the sub-unit without disconnecting the external wiring

When drawing out the subunit, be sure to take the following steps to avoid the unwanted operation of primary equipment:

- Open control power supply of the relay (Note: Take care that the appropriate circuit is opened.)
- Shunt / Isolate the CT circuit
- Lock out the tripping circuit including breakers etc.
- Disconnect the main control circuits

As an additional precaution, the CT circuit is provided with an automatic short-circuiting mechanism. This will ensure that the CT secondary circuit is not opened when the sub-unit is removed even if the CT circuits have not been shunted.

### 3.3.1. Procedures for drawing out subunit

#### (1) Removing screws



When drawing out the subunit from the outer case, open upper & lower screw covers at the front side of the subunit and detach both screws.

#### (2) Drawing out the subunit



Draw out subunit horizontally by using fingers on the upper & lower grooves of it.

### 3.3.2. Procedures for housing subunit

#### (1) Inserting the subunit

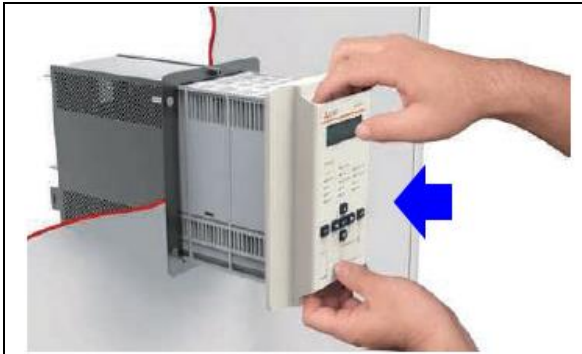

Insert subunit into the outer case horizontally by using fingers on the upper & lower grooves of it. Ensure that there is no gap between front side of the subunit and outer case.

#### (2) Fixing the screws



Tighten upper & lower screws and fix the subunit to the outer case. After that, close screw covers.

### 3.4. Mounting

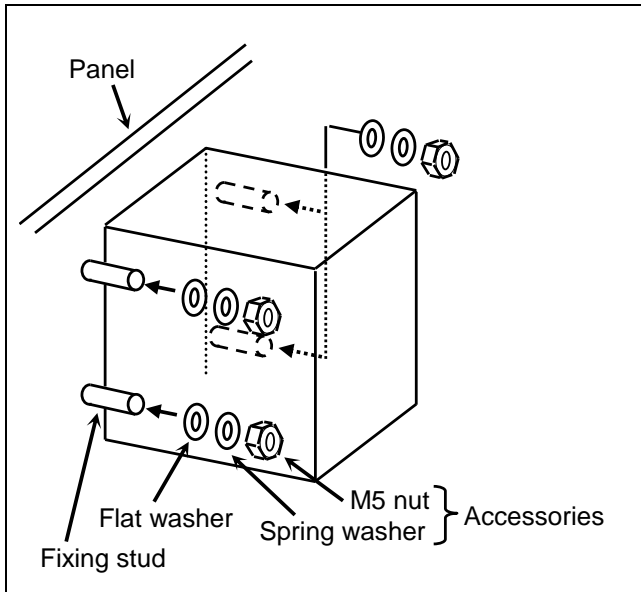

When inserting this relay into control panel, take care in order not to damage it.  
After inserting, fix this relay with washers and nuts which are supplied with the product.

Section 2.3 explains Cut-Out dimensions of panel.

### 3.5. Distance between two devices

If you install more than one relay devices in a control panel, please leave 50 mm between one device and another.

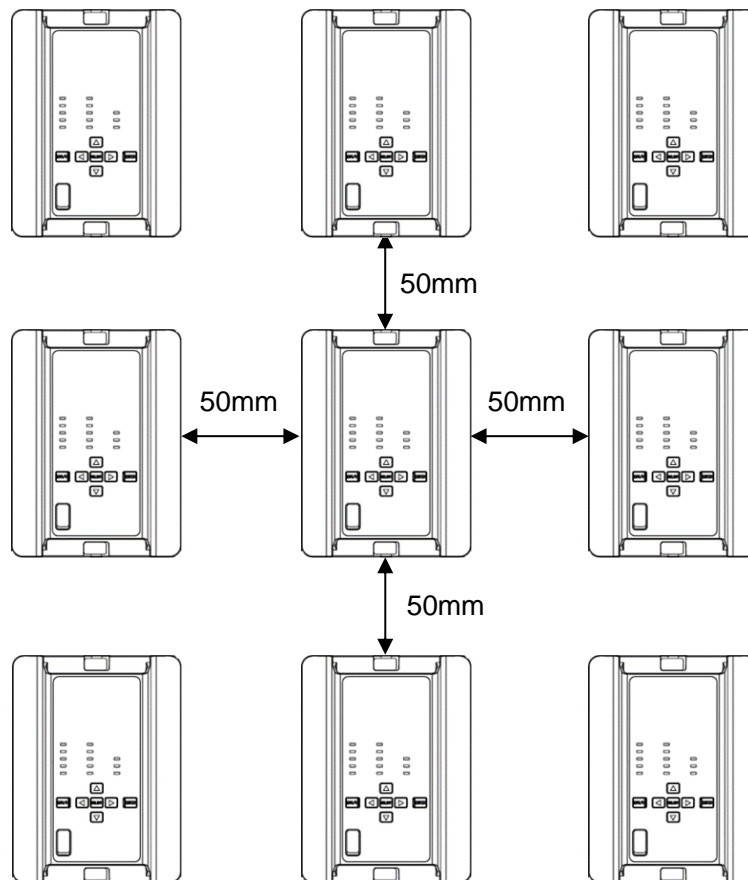

## 4. Connection

### 4.1. Precautions for wiring work

#### (1) Multiplexing

Important facilities should be provided with fail-safe measures such as dual or duplex system in order to improve reliability of the facilities.

#### (2) Effects of external surge

Some types of surge with a certain condition may negatively affect the relay. If so, take it into account to install surge absorbers. (MF type surge absorbers made by Mitsubishi Electric, for example.)

#### (3) Guarantee of control power supply against power interruption

The control power supply of the relay is not guaranteed against power interruption. When you do not have an uninterruptible power supply (UPS), please purchase it that is made by Mitsubishi Electric or commercially available. When you select UPS, please confirm rated values, ambient temperature, and other service conditions.

#### (4) Inrush current of control power supply

Since inrush current may flow in the relay when the control power supply is turned on as shown in the figure below, make consideration of this point when selecting the breaker for the control power supply circuit.

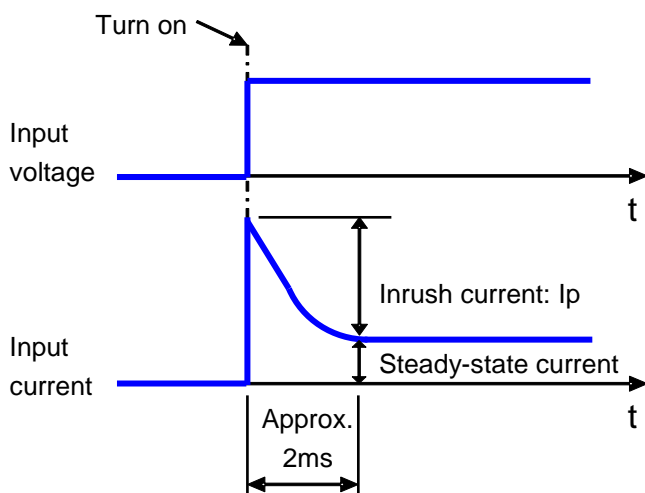

Input voltage	Inrush current: $I_p$
DC100V	Approx. 20A or less
DC220V	Approx. 55A or less
AC100V	Approx. 25A or less
AC220V	Approx. 65A or less

**Fig. 4-1 Inrush current of control power supply**

#### (5) Self-diagnosis output circuit

In order to be able to continue monitoring even if the built-in power fuse is blown, the self-diagnosis output circuit adopts normally-closed contact which is excited (opened) at the time of normal condition of monitoring. Therefore, connect the timer to the external wiring. For details, refer to Fig. 4-2.

#### (6) Trip circuit

There are two kinds of output contacts for the trip circuits and the control circuits. Please keep in mind that the output contacts for control circuits cannot be used for the trip circuit. (If used, the contact may burn.)

Connect the pallet contact (52a) of the circuit breaker to the trip circuit.

#### (7) Ground circuit

Be sure to earth the ground terminal located on the back of the relay with D class grounding method whose ground resistance is 100  $\Omega$  or less.

#### (8) ZCT circuit

It is necessary to reduce surge or noise which is entered into the relay as much as possible, thus the connection from ZCT to the relay should be done with 2 core shielded cable whose cross-sectional area is 0.75 ~ 1 mm<sup>2</sup>. The shield of the cable should be connected to the ground terminal of the relay or that of the cubicle.

The burden should be less than 5 $\Omega$  as a round-trip (e.g. about 100 meters one way for 0.75 mm<sup>2</sup> cable).

## 4.2. Terminal layout

Regarding to the terminal layout, refer to Section 2.2. The screw size of each terminal is M3.5. Recommended wire size is 2mm<sup>2</sup> or less.

### 4.3. External connection

#### 4.3.1. Connection example of control circuit

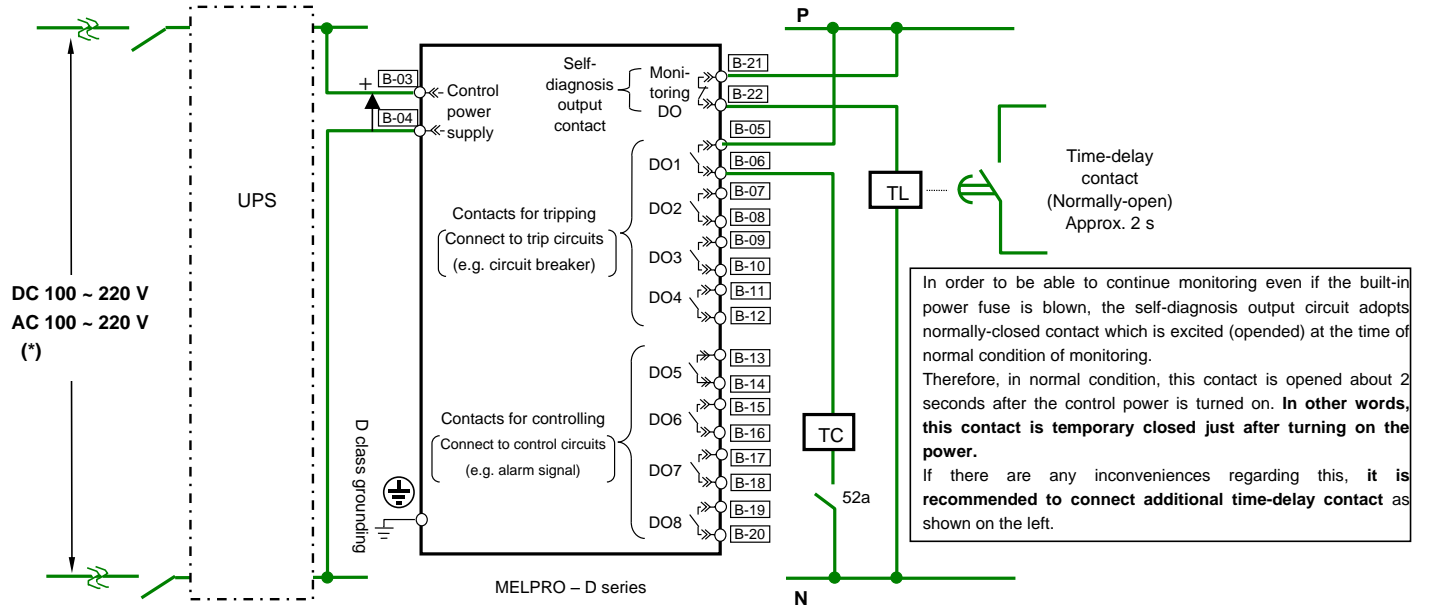

(\*) Refer to Section 4.1-(3) "Guarantee of control power supply against power interruption".

Fig. 4-2 Connection example of control power supply and self-diagnosis output circuit.

#### 4.3.2. Connection example of input circuit

This figure shows concept of the connection to the relay. Therefore, the position or condition of CT, VT, and other devices sometimes differs from the actual state.

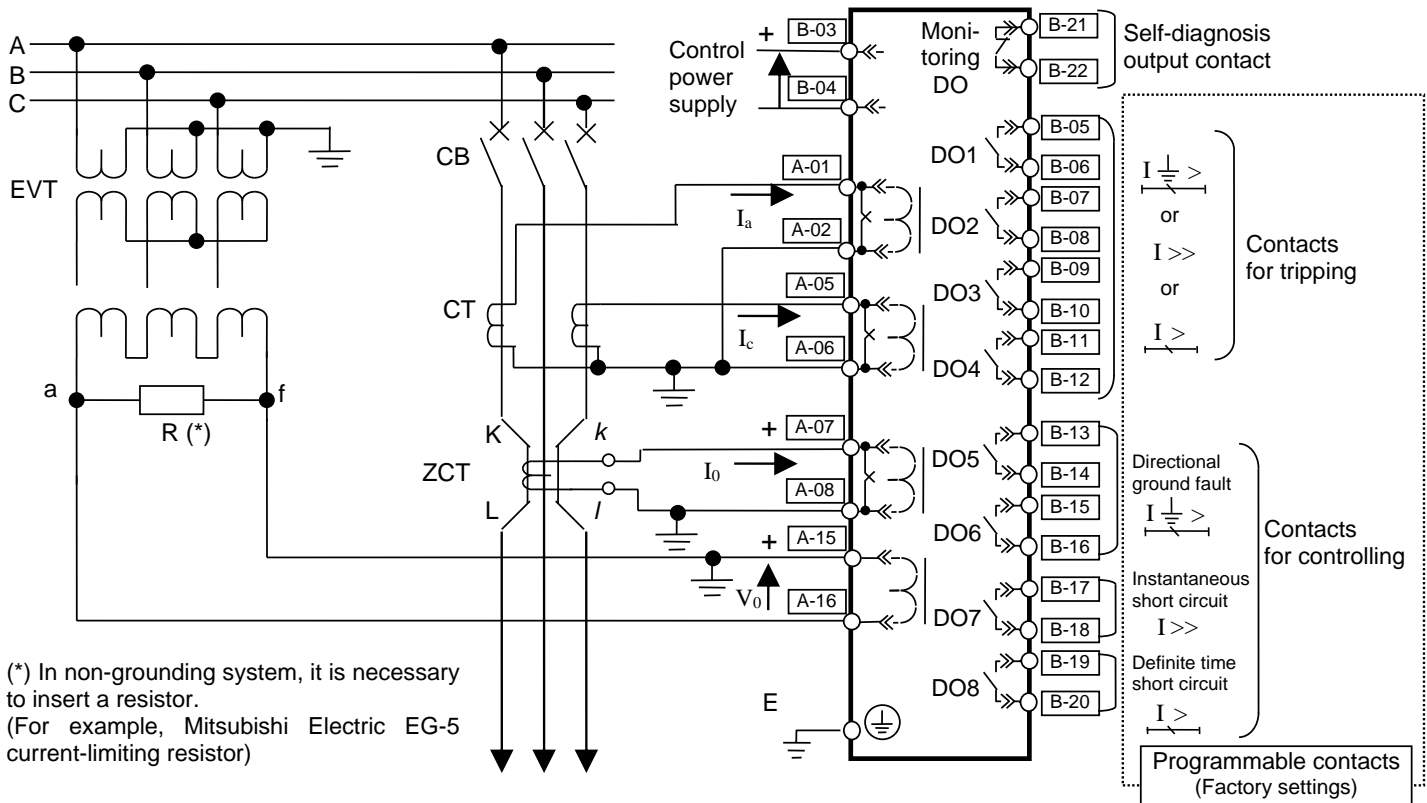

Fig. 4-3 CFP1-A42D1 Example of AC input circuit



## 5. Human machine interface

There are three ways to set and operate the relay:

- (1) Operation from the front panel
- (2) Operation from a locally connected PC

This chapter describes about “(1) Operation from the front panel” by pushbuttons and the indication display. The operation method (2) is described in a separate volume. Please refer to the following document.

Title of document	Document No.
MELPRO-D Series Protection Relay PC-HMI Instruction Manual	JEP0-IL9504

### 5.1. Pushbutton switches and indication display

This section describes the pushbuttons and indication display on the front panel.

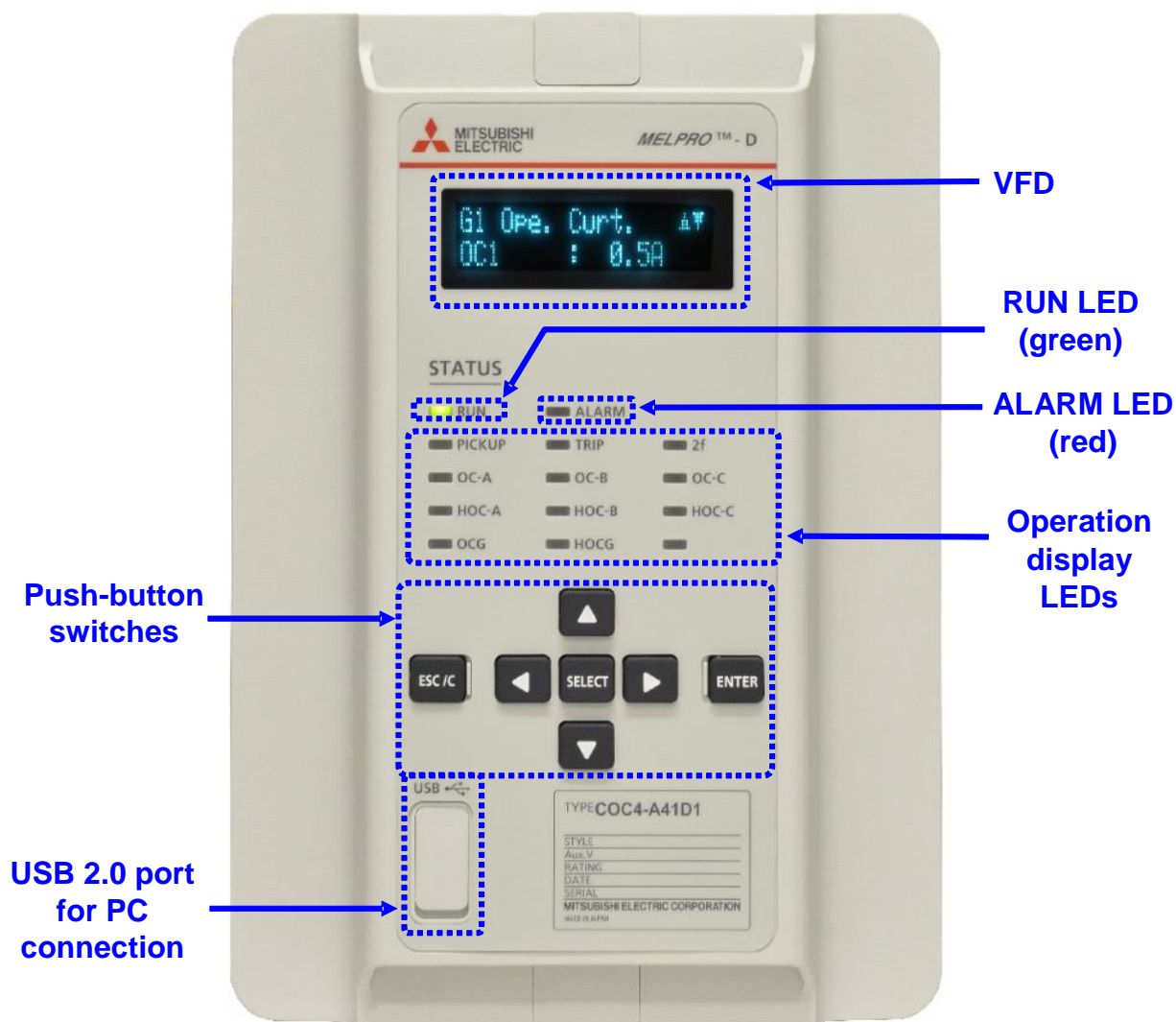
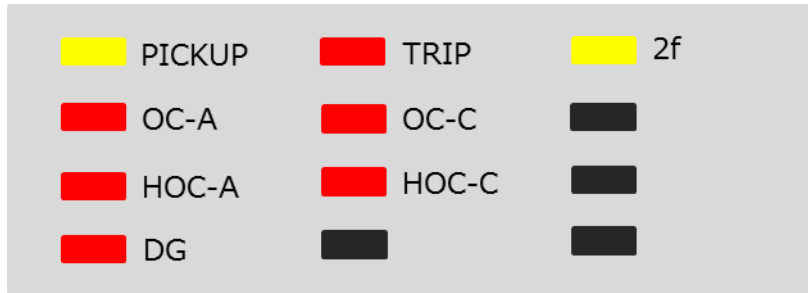
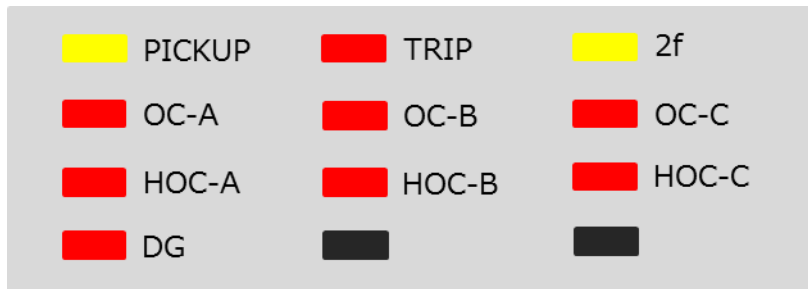

Fig. 5-1 Front view of relay



**Fig. 5-2 Operation display LEDs of CFP1-A42D1**



**Fig. 5-3 Operation display LEDs of CFP1-A43D1**

**Table 5-1 Description of front panel**

Name		Description		
VFD (Vacuum Fluorescent Display) (18 characters x 2 lines)		Shows various menus and values of the DISPLAY/SETTING mode. If you has not operated any push buttons for more than 30 minutes, the VFD is automatically turned off. In the METERING menu, you can expand the character size.		
RUN LED	Green	Shows the result of constant supervision. Illuminated for a normal condition. When this LED light is turned off, the relay functions are not working.		
ALARM LED	Red	Shows the result of constant supervision. Illuminated for an abnormal condition.		
Operation display LED	PICKUP	Yellow	Illuminated for detection of protection element (OR of all elements). This LED will be turned off after resetting.	
	TRIP	Red	Illuminated when the definitive signal (TRIP signal) of protection element is issued (OR of all elements). (*)	
	2f	Yellow	Illuminated for detection of 2f. This LED will be turned off after resetting.	
	CFP1-A42D1	OC-A	Red	Illuminated when the definitive signal of definite time or IDMT overcurrent element (A phase) is issued. (*)
		OC-C	Red	Illuminated when the definitive signal of definite time or IDMT overcurrent element (C phase) is issued. (*)
		HOC-A	Red	Illuminated when the definitive signal of instantaneous overcurrent element (A phase) is issued. (*)
		HOC-C	Red	Illuminated when the definitive signal of instantaneous overcurrent element (B phase) is issued. (*)
		DG	Red	Illuminated when the definitive signal of directional ground fault element is issued. (*)
	CFP1-A43D1	OC-A	Red	Illuminated when the definitive signal of definite time or IDMT overcurrent element (A phase) is issued. (*)
		OC-B	Red	Illuminated when the definitive signal of definite time or IDMT overcurrent element (B phase) is issued. (*)
		OC-C	Red	Illuminated when the definitive signal of definite time or IDMT overcurrent element (C phase) is issued. (*)
		HOC-A	Red	Illuminated when the definitive signal of instantaneous overcurrent element (A phase) is issued. (*)
		HOC-B	Red	Illuminated when the definitive signal of instantaneous overcurrent element (B phase) is issued. (*)
		HOC-C	Red	Illuminated when the definitive signal of instantaneous overcurrent element (C phase) is issued. (*)
DG		Red	Illuminated when the definitive signal of directional ground fault element is issued. (*)	

(\*) The LED continues lighting after resetting the protection element. You can turn the LED off by pushing ESC/C button if the trouble has been resolved.

Name		Description
Pushbutton switch	SELECT	<ul style="list-style-type: none"> <li>Moves to the menu one level lower</li> <li>Confirms selection of input item</li> <li>Confirms input value</li> <li>Reconfirms after pressing ENTER in SETTING mode</li> </ul>
	ENTER	<ul style="list-style-type: none"> <li>Starts operation in SETTING mode</li> </ul>
	ESC/C	<ul style="list-style-type: none"> <li>Turns off VFD</li> <li>Turns off operation indicator LEDs by holding down (for 3s or longer)</li> </ul>
	◀	<ul style="list-style-type: none"> <li>Moves to the menu one level higher</li> <li>Moves to digit on the left in the value input screen</li> <li>Discards the input value in the input screen and moves to the menu one level higher</li> </ul>
	▶	<ul style="list-style-type: none"> <li>Moves to digit on the right in the value input screen</li> </ul>
	▼ ▲	<ul style="list-style-type: none"> <li>Moves to the menu above/below</li> <li>Increments/decrements the input value in the value input screen</li> </ul>
USB2.0 port		For PC connection (Commercial USB cable is available)

## 5.2. List of menus

The operation mode includes the DISPLAY and SETTING modes, which respectively have different menus. lists the menus available in the respective modes.

**Table 5-2 List of menu**

○: DISPLAY only   ⊙: DISPLAY and SETTING   -: Not shown

Menu		Operation mode	
		DISPLAY	SETTING
Status (STATUS)	Clock (CLOCK)	○	-
	Measured analog value (METERING)	○	-
	DI/DO status (DIGITAL I/O)	○	-
	Trip counter (TRIP COUNTER)	○	-
	Device name (DEVICE NAME)	○	-
Record (RECORD)	Fault record (FAULT RECORD)	○	-
	Event record (EVENT RECORD)	○	-
	Access record (ACCESS RECORD)	○	-
	Alarm record (ALARM RECORD)	○	-
Setting (SETTING)	Active group (ACTIVE WG)	○	⊙
	Group 1 setting (G1)	○	⊙
	Group 2 setting (G2)	○	⊙
Configuration (CONFIG)	Communication setting (COMMUNICATION)	○	⊙
	Clock adjustment (CLOCK ADJUST)	-	⊙
	Analog value display switching (METERING)	○	⊙
	Trip counter (TRIP COUNTER)	○	⊙
	Disturbance record (DISTURBANCE)	○	⊙
	Password use/unuse (PASSWORD USE)	-	⊙
	Password registration (PASSWORD REGIST)	-	⊙
Test (TEST)	DO contact test (CONTACT TEST)	-	⊙
	Test mode (MODE)	-	⊙
	LED/VFD lighting test (LED/VFD TEST)	-	⊙
Clear record (RECORD- CLR)	Clear fault record (FAULT REC CLEAR)	-	⊙
	Clear alarm record (ALARM REC CLEAR)	-	⊙
	Clear event record (EVENT REC CLEAR)	-	⊙

## 5.3. Operation method

This section describes the operations for mode selection and various menus.

### 5.3.1. DISPLAY/SETTING mode selection

Press a key except for ESC/C when VFD is OFF to show the DISPLAY/SETTING mode selection screen. The DISPLAY and SETTING modes offer different sets of menus available. For the details about the menus in the respective modes, see Table 5-2.

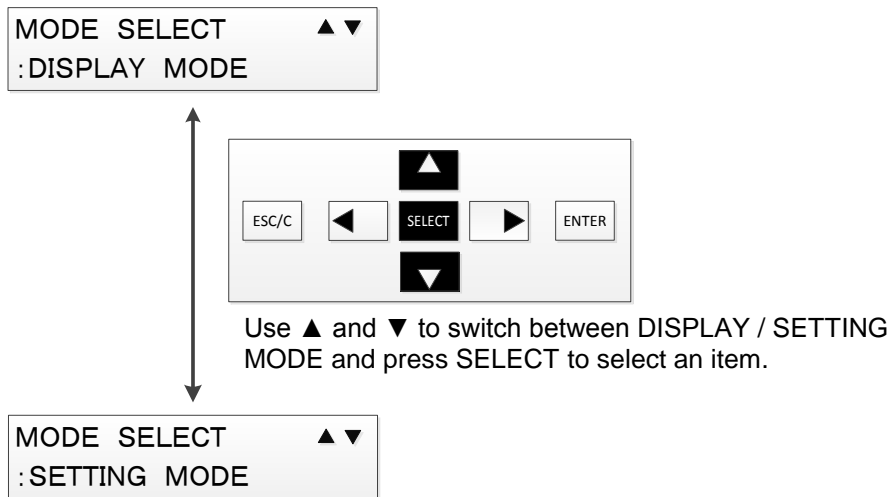

### 5.3.2. DISPLAY mode menu operations

This subsection describes the menu operations in the DISPLAY mode.

The menu screen has four selectable items. Use the Up and Down keys to select the item and press SELECT.

For the details about the menus available in the DISPLAY mode, see Table 5-2.

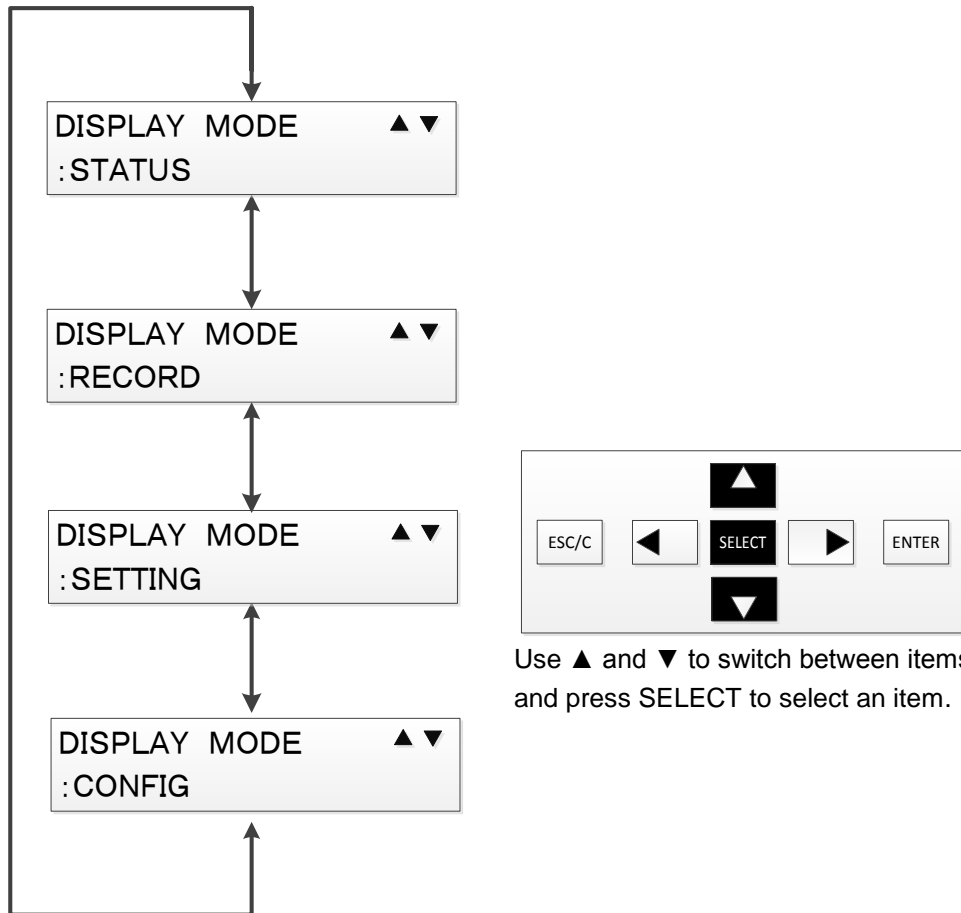

### 5.3.2.1. Status (STATUS) menu

This subsection describes the Status (STATUS) menu.

The Status menu shows the current time, measured value, DI/DO status, trip counter, device name and Software version.

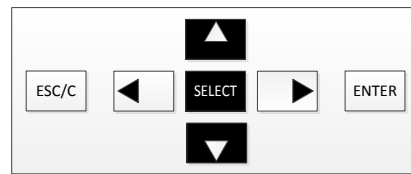
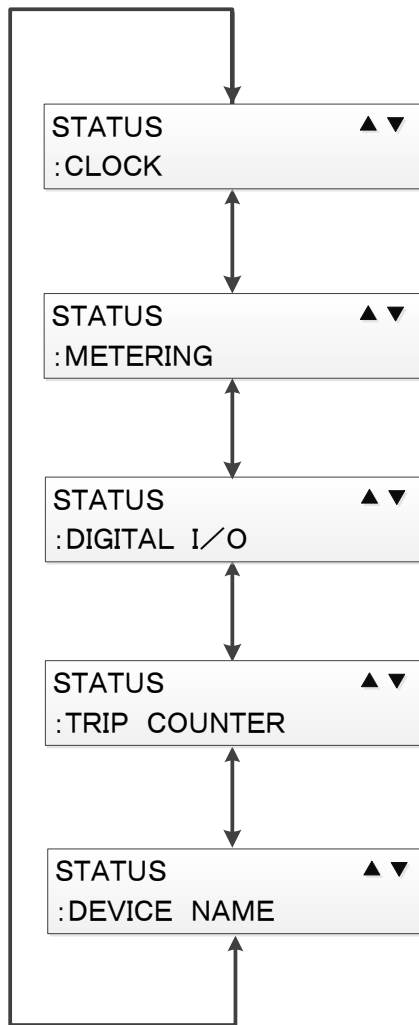

Use ▲ and ▼ to switch between items and press SELECT to select an item.

### 5.3.2.1.1. Clock (CLOCK) menu

[Operation path] DISPLAY MODE > STATUS > CLOCK

The clock (CLOCK) menu allows viewing of the current time and synchronization type.

CLOCK	(LOCAL)
1970-01-01	00:00:00

The text in the upper right part of the screen indicates the synchronization type for the time shown.  
(Part showing "LOCAL" in figure above)

5.3.2.1.2. Measured analog value (METERING) menu

[Operation path] DISPLAY MODE > STATUS > METERING

The Measured analog value (METERING) menu allows viewing of the current measured value. The Configuration menu can specify the measured value of the primary or secondary value of CT/VT. For the setting procedure, see 5.3.4.2.3.

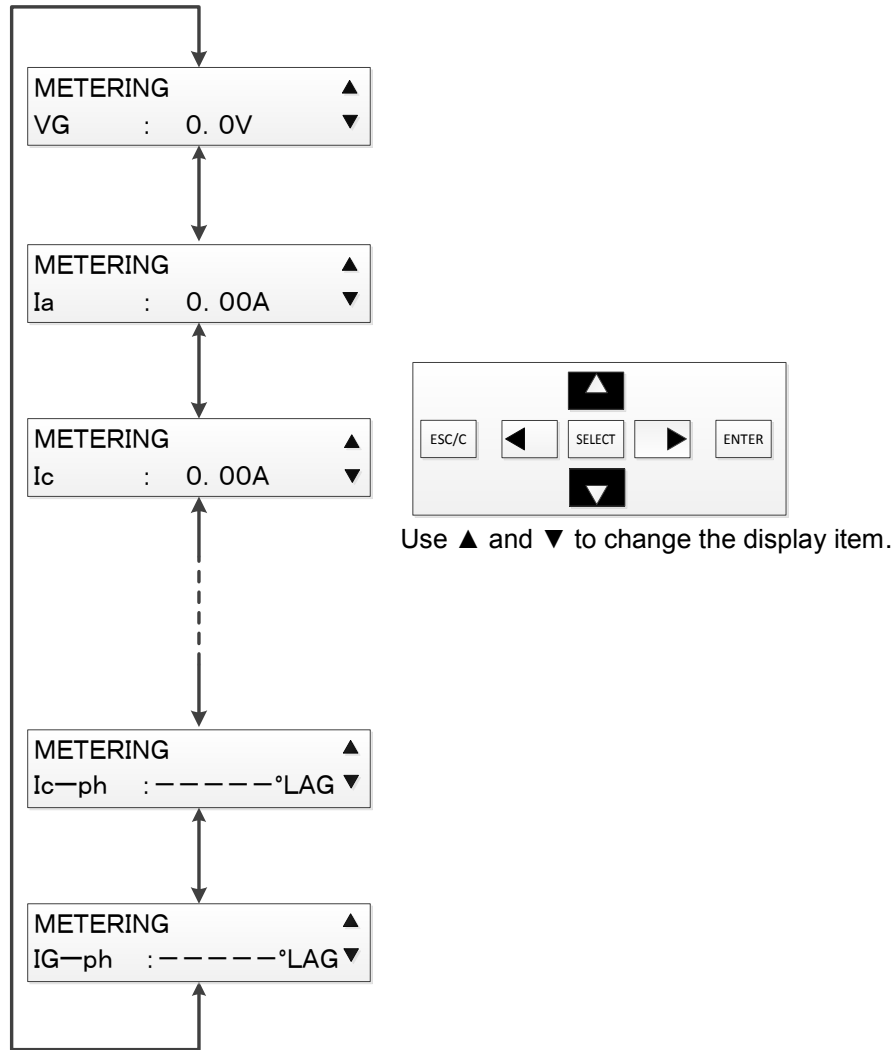

Note: This is an example.

By pressing SELECT, you can expand the character size of the measured value. Pressing SELECT again goes back to the original state.

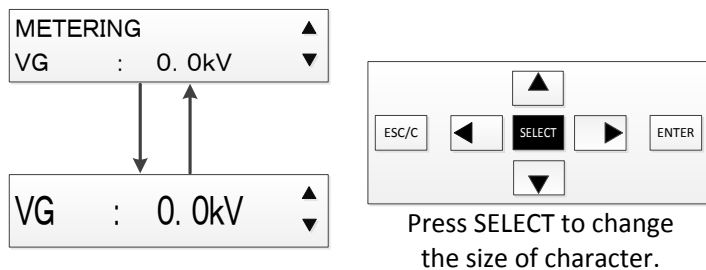

**Table 5-3 Measured value display items**

• CFP1-A42D1

No.	Signal name	Unit (primary/secondary)
1	VG	kV / V
2	Ia	A / A
3	Ic	A / A
4	IG	A / mA
5	VG-ph	°LAG / °LAG
6	Ia-ph	°LAG / °LAG
7	Ic-ph	°LAG / °LAG
8	IG-ph	°LAG / °LAG

• CFP1-A43D1

No.	Signal name	Unit (primary/secondary)
1	VG	kV / V
2	Ia	A / A
3	Ib	A / A
4	Ic	A / A
5	IG	A / A
6	VG-ph	°LAG / °LAG
7	Ia-ph	°LAG / °LAG
8	Ib-ph	°LAG / °LAG
9	Ic-ph	°LAG / °LAG
10	IG-ph	°LAG / °LAG

5.3.2.1.3. DI/DO status (DIGITAL I/O) menu

[Operation path] DISPLAY MODE > STATUS > DIGITAL I/O

The DI/DO status (DIGITAL I/O) menu allows viewing of the current DI/DO.

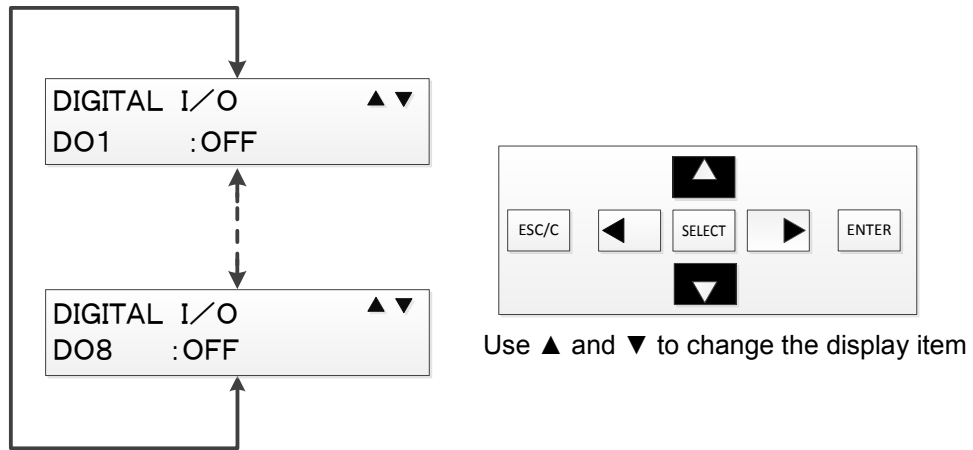

**Table 5-4 Show DI/DO status Display items**

No.	Signal name
1	DO1
2	DO2
3	DO3
4	DO4
5	DO5
6	DO6
7	DO7
8	DO8

5.3.2.1.4. Trip counter (TRIP COUNTER) menu

[Operation path] DISPLAY MODE > STATUS > TRIP COUNTER

The Trip counter (TRIP COUNTER) menu allows viewing of the number of trips.

TRIP COUNTER
Trip CNT : 0

5.3.2.1.5. Device name (DEVICE NAME) menu

[Operation path] DISPLAY MODE > STATUS > DEVICE NAME

The Device name (DEVICE NAME) menu allows viewing of the device name.

DEVICE NAME
DEVICE 1

### 5.3.2.2. Record (RECORD) menu

This subsection describes the operation logs in the Record (RECORD) menu. The Record menu allows viewing four types of log data. (Fault record, Event record, Access record and Alarm record)

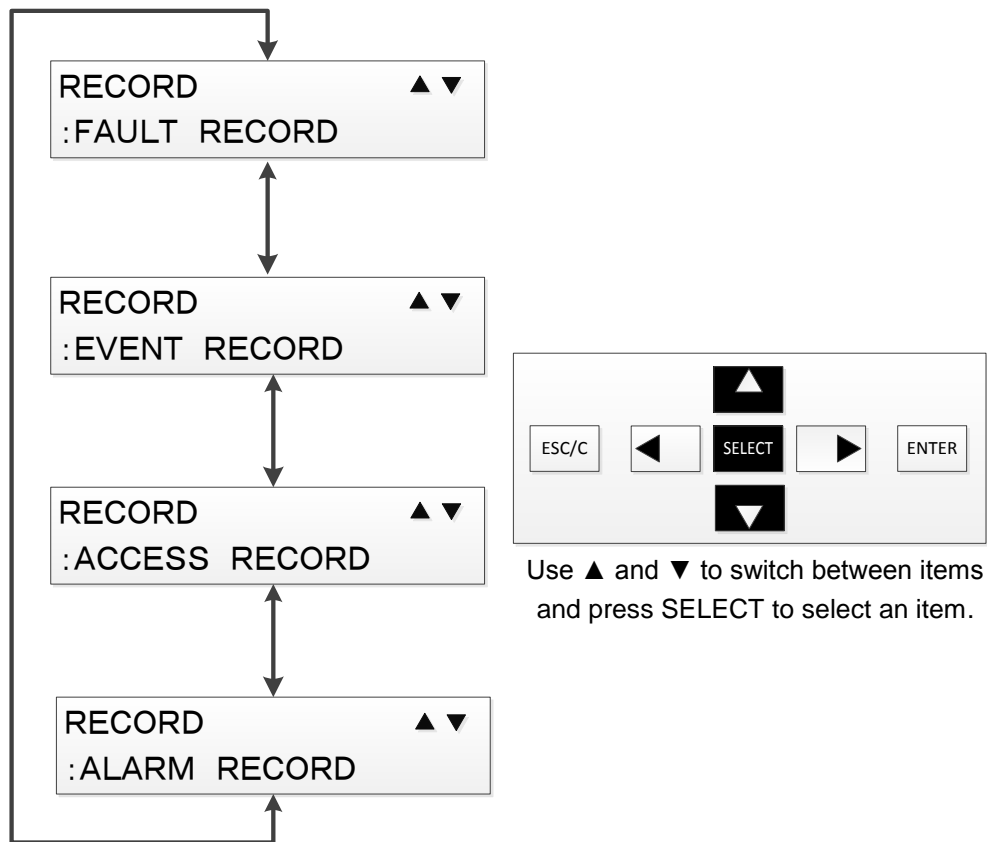

5.3.2.2.1. Fault record (FAULT RECORD) menu

[Operation path] DISPLAY MODE > RECORD > FAULT RECORD

The Fault record (FAULT RECORD) menu allows viewing of the time, operating values and operating elements when the fault is detected. Fault records of up to five phenomena are stored and the respective fault record can be viewed. For selecting record for display, use the Up and Down keys to select the date of the fault record and press SELECT.

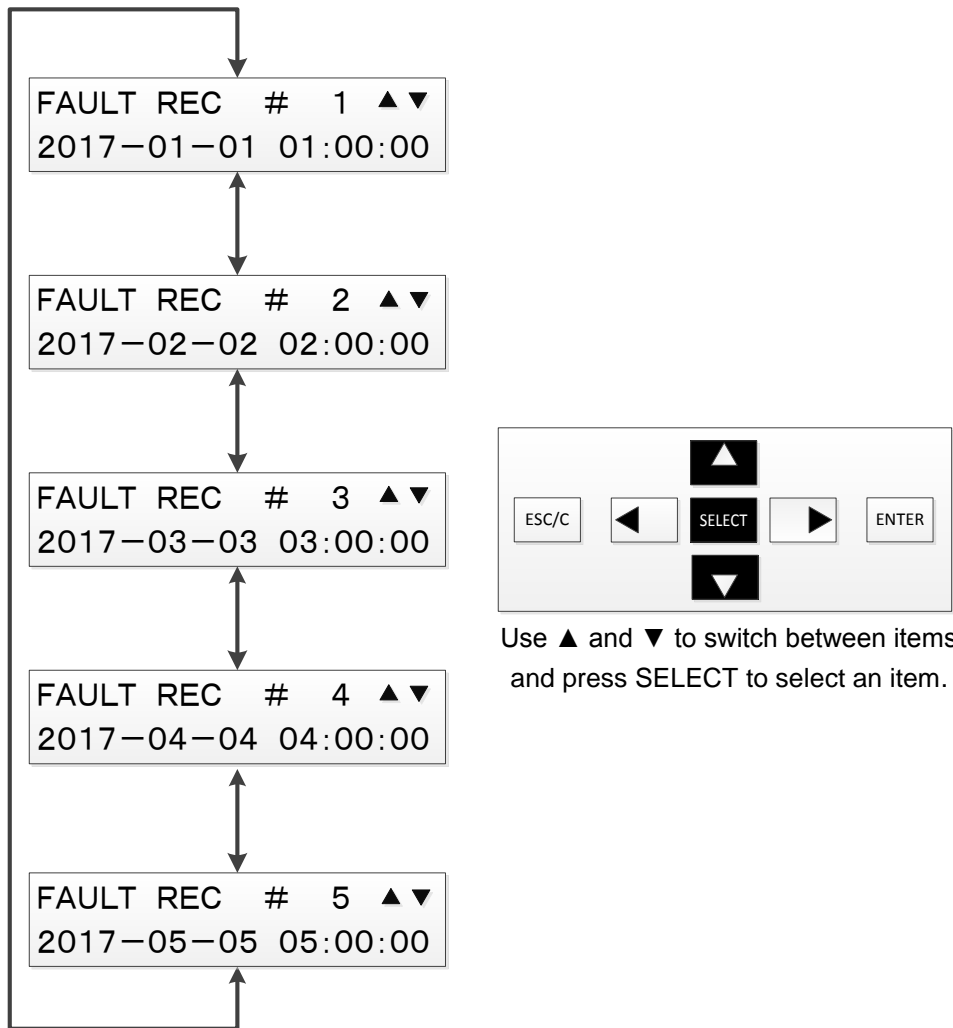

Note: This is an example.

After a fault record is selected, use the Up and Down keys to view the trip factors and measured values.

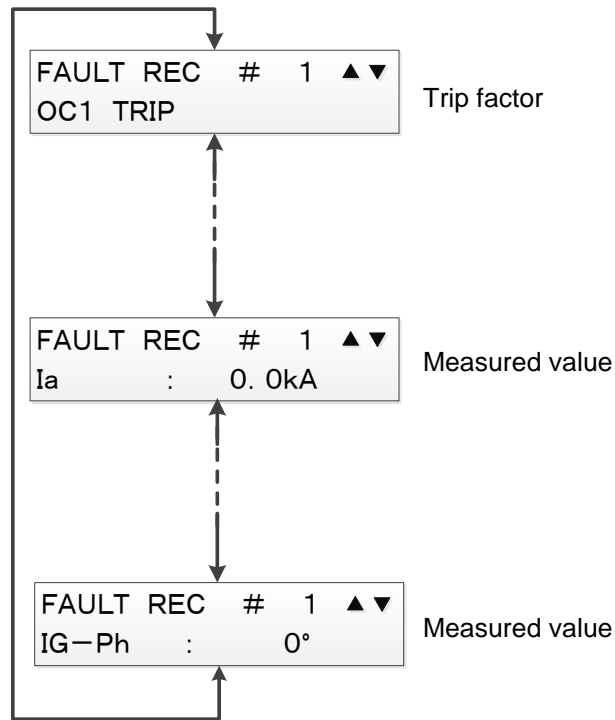

Note: This is an example.

**Table 5-5 Elements of fault records (CFP1-A42D1)**

Element name displayed
OC1-A Trip
OC1-C Trip
OC2-A Trip
OC2-C Trip
OC3-A Trip
OC3-C Trip
OC4-A Trip
OC4-C Trip
DIRG1 Trip
DIRG2 Trip

**Table 5-6 Elements of fault records (CFP1-A43D1)**

Element name displayed
OC1-A Trip
OC1-B Trip
OC1-C Trip
OC2-A Trip
OC2-B Trip
OC2-C Trip
OC3-A Trip
OC3-B Trip
OC3-C Trip
OC4-A Trip
OC4-B Trip
OC4-C Trip
DIRG1 Trip
DIRG2 Trip

**Table 5-7 Measured values of fault records (CFP1-A42D1)**

No.	Signal name	Unit
1	VG	kV
2	Ia	A
3	Ic	A
4	IG	A
5	VG-ph	°LAG
6	Ia-ph	°LAG
7	Ic-ph	°LAG
8	IG-ph	°LAG

**Table 5-8 Measured values of fault records (CFP1-A43D1)**

No.	Signal name	Unit
1	VG	kV
2	Ia	A
3	Ib	A
4	Ic	A
5	IG	A
6	VG-ph	°LAG
7	Ia-ph	°LAG
8	Ib-ph	°LAG
9	Ic-ph	°LAG
10	IG-ph	°LAG

5.3.2.2.2. Event record (EVENT RECORD) menu

[Operation path] DISPLAY MODE > RECORD > EVENT RECORD

The Event record (EVENT RECORD) menu allows viewing of event records saved. Event records of up to 512 events are stored and the respective event record can be viewed. Press the Up and Down keys to switch the indication on the screen as below.

Date of occurrence > Record description > Date of occurrence...

Press the Right key to display from the current event record to the past 10<sup>th</sup> record.

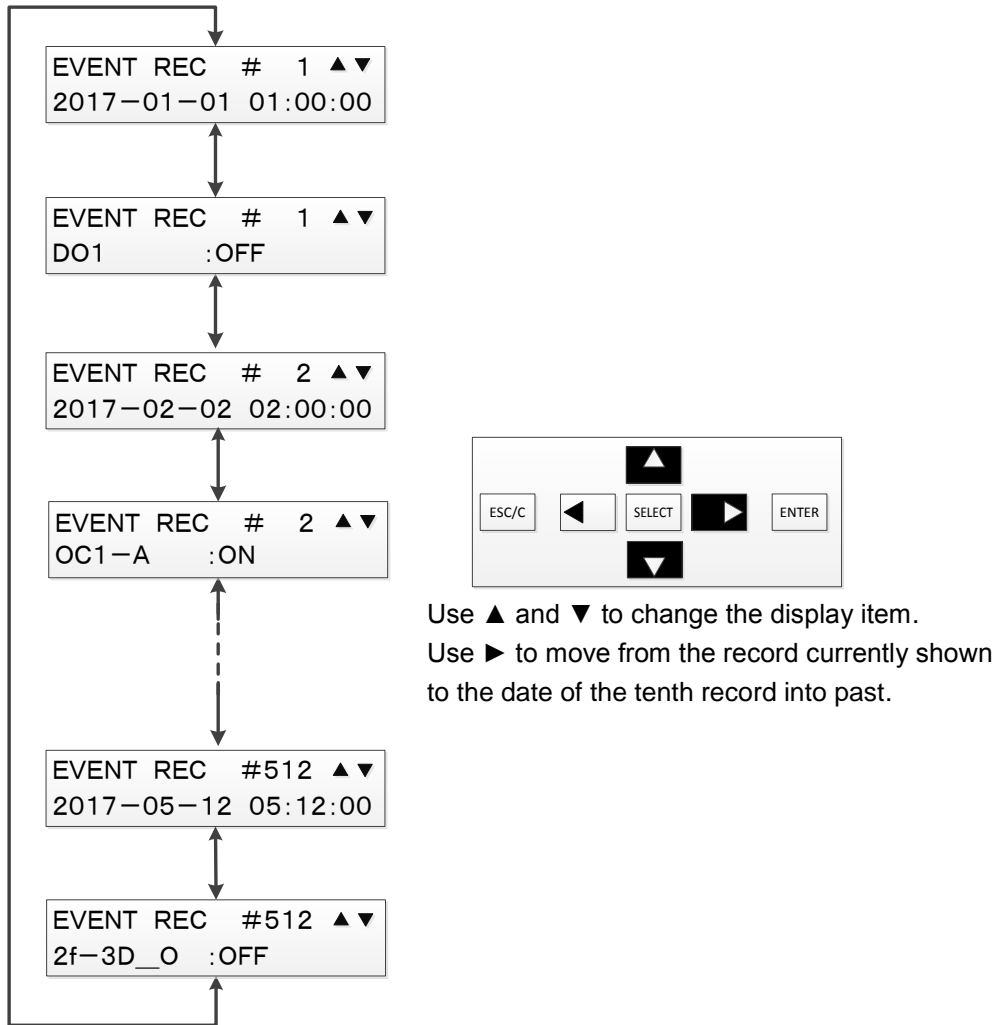

Use ▲ and ▼ to change the display item.  
Use ▶ to move from the record currently shown to the date of the tenth record into past.

Note: This is an example.

**Table 5-9 List of event record (CFP1-A42D1)**

Event name	
OC1-A	Definitive signal of OC1 A-phase or forced operation from PC-HMI
OC1-C	Definitive signal of OC1 C-phase or forced operation from PC-HMI
OC2-A	Definitive signal of OC2 A-phase or forced operation from PC-HMI
OC2-C	Definitive signal of OC2 C-phase or forced operation from PC-HMI
OC3-A	Definitive signal of OC3 A-phase or forced operation from PC-HMI
OC3-C	Definitive signal of OC3 C-phase or forced operation from PC-HMI
OC4-A	Definitive signal of OC4 A-phase or forced operation from PC-HMI
OC4-C	Definitive signal of OC4 C-phase or forced operation from PC-HMI
DIRG1	Definitive signal of DIRG1 or forced operation from PC-HMI
DIRG2	Definitive signal of DIRG2 or forced operation from PC-HMI
TCNT_ALM	Alarm of trip counter
DO1	Status of DO1
DO2	Status of DO2
DO3	Status of DO3
DO4	Status of DO4
DO5	Status of DO5
DO6	Status of DO6
DO7	Status of DO7
DO8	Status of DO8
ALARM	Abnormal condition of constant supervision (serious failure)
ALARM-L	Abnormal condition of constant supervision (minor failure)
RY-LOCK	Locking of relay
2f-3D_0	Detection of 2f (OR of all phases)
ALLEL-O	OR of all definitive signals
DS_TRIG	Pulse signal from start-up until the end of data saving (Except for pre-fault time)
SV-LK	Locking of supervision
TCNT-LK	Locking of trip counter

**Table 5-10 List of event record (CFP1-A43D1)**

Event name	
OC1-A	Definitive signal of OC1 A-phase or forced operation from PC-HMI
OC1-B	Definitive signal of OC1 B-phase or forced operation from PC-HMI
OC1-C	Definitive signal of OC1 C-phase or forced operation from PC-HMI
OC2-A	Definitive signal of OC2 A-phase or forced operation from PC-HMI
OC2-B	Definitive signal of OC2 B-phase or forced operation from PC-HMI
OC2-C	Definitive signal of OC2 C-phase or forced operation from PC-HMI
OC3-A	Definitive signal of OC3 A-phase or forced operation from PC-HMI
OC3-B	Definitive signal of OC3 B-phase or forced operation from PC-HMI
OC3-C	Definitive signal of OC3 C-phase or forced operation from PC-HMI
OC4-A	Definitive signal of OC4 A-phase or forced operation from PC-HMI
OC4-B	Definitive signal of OC4 B-phase or forced operation from PC-HMI
OC4-C	Definitive signal of OC4 C-phase or forced operation from PC-HMI
OC4-3_O	Definitive signal of any OC4 of A, B, and C phase or forced operation from PC-HMI
DIRG1	Definitive signal of DIRG1 or forced operation from PC-HMI
DIRG2	Definitive signal of DIRG2 or forced operation from PC-HMI
TCNT_ALM	Alarm of trip counter
DO1	Status of DO1
DO2	Status of DO2
DO3	Status of DO3
DO4	Status of DO4
DO5	Status of DO5
DO6	Status of DO6
DO7	Status of DO7
DO8	Status of DO8
ALARM	Abnormal condition of constant supervision (serious failure)
ALARM-L	Abnormal condition of constant supervision (minor failure)
RY-LOCK	Locking of relay
2f-3D_0	Detection of 2f (OR of all phases)
ALLEL-O	OR of all definitive signals
DS_TRIG	Pulse signal from start-up until the end of data saving (Except for pre-fault time)
SV-LK	Locking of supervision
TCNT-LK	Locking of trip counter

5.3.2.2.3. Access record (ACCESS RECORD) menu

[Operation path] DISPLAY MODE > RECORD > ACCESS RECORD

The Access record (ACCESS RECORD) menu allows viewing of the saved access records. Access records of up to 512 accesses are stored and the records for the respective accesses can be viewed. Press the Up and Down keys to switch the indication on the screen as below.

Date of occurrence > Record description > Date of occurrence...

Press the Right key to display from the current access record to the past 10<sup>th</sup> record.

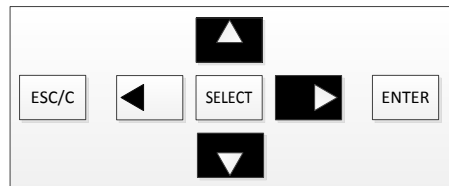
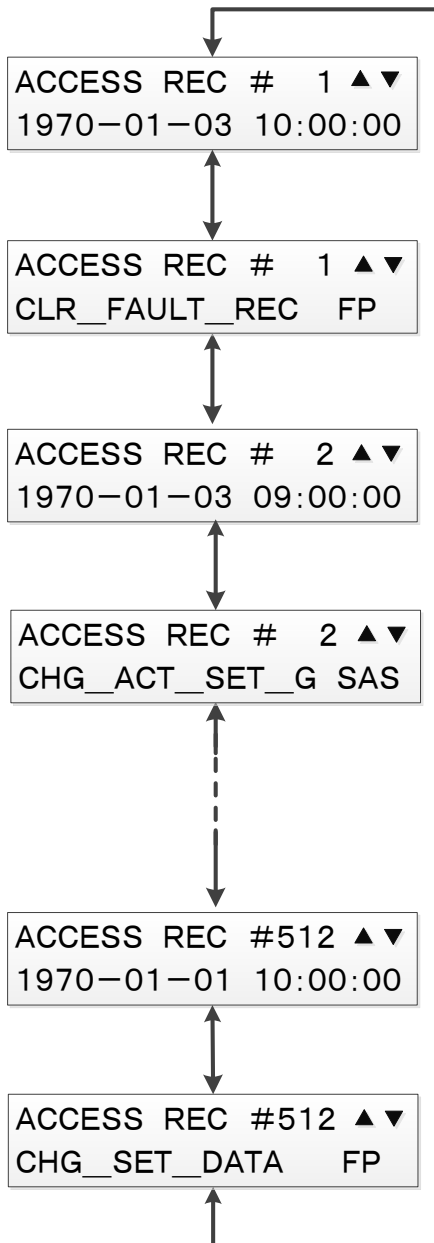

Use ▲ and ▼ to change the display item.  
Use ► to move from the record currently shown to the date of the tenth record into past.

Note: This is an example.

**Access record description registered (operator)**

Display item	Operation description
RY	Front panel
PC	PC-HMI
AUT	Automatic cancelation on device

**Access record description registered (operation description)**

Display item	Operation description
CHG_ACT_SET_G	Change of active setting group
CHG_DIST_REC_T	Change of configuration of disturbance record
CHG_USE_PASSWD	Change of password use setting
CHG_PASSWD	Change of password
CHG_USB_CONN	Change of USB connection channel
CHG_TRIP_CNTR	Change of trip counter
CHG_DEV_NAME	Change of device name
CHG_CFG_METER	Change of configuration of analog measurement status display
CHG_TIMEMANAGE	Change of configuration of time management
CHG_CONTACT_T	Change of configuration of DO contact test
CHG_PLC_DATA	Change of PLC data
CHG_SET_DATA	Change of relay setting
CLR_FAULT_REC	Clearing of fault/disturbance record
CLR_ALARM_REC	Clearing of alarm record
CLR_EVENT_REC	Clearing of event record
ADJ_CLOCK	Adjustment of system clock
ACT_TST_MODE	Activation of test mode
DEACT_TST_MODE	Deactivation of test mode
RESET_LED	LED reset
STA_CONTACTTST	Start of DO contact test
STP_CONTACTTST	Stop of DO contact test

5.3.2.2.4. Alarm record (ALARM RECORD) menu

[Operation path] DISPLAY MODE > RECORD > ALARM RECORD

The Alarm record (ALARM RECORD) menu allows viewing of the saved alarm records. Alarm records of up to 200 alarms are stored and the records for the respective alarms can be viewed. Press the Up and Down keys to switch the indication on the screen as below.

Date of occurrence > Record description > Date of occurrence...

Press the Right key to display from the current alarm record to the past 10<sup>th</sup> record.

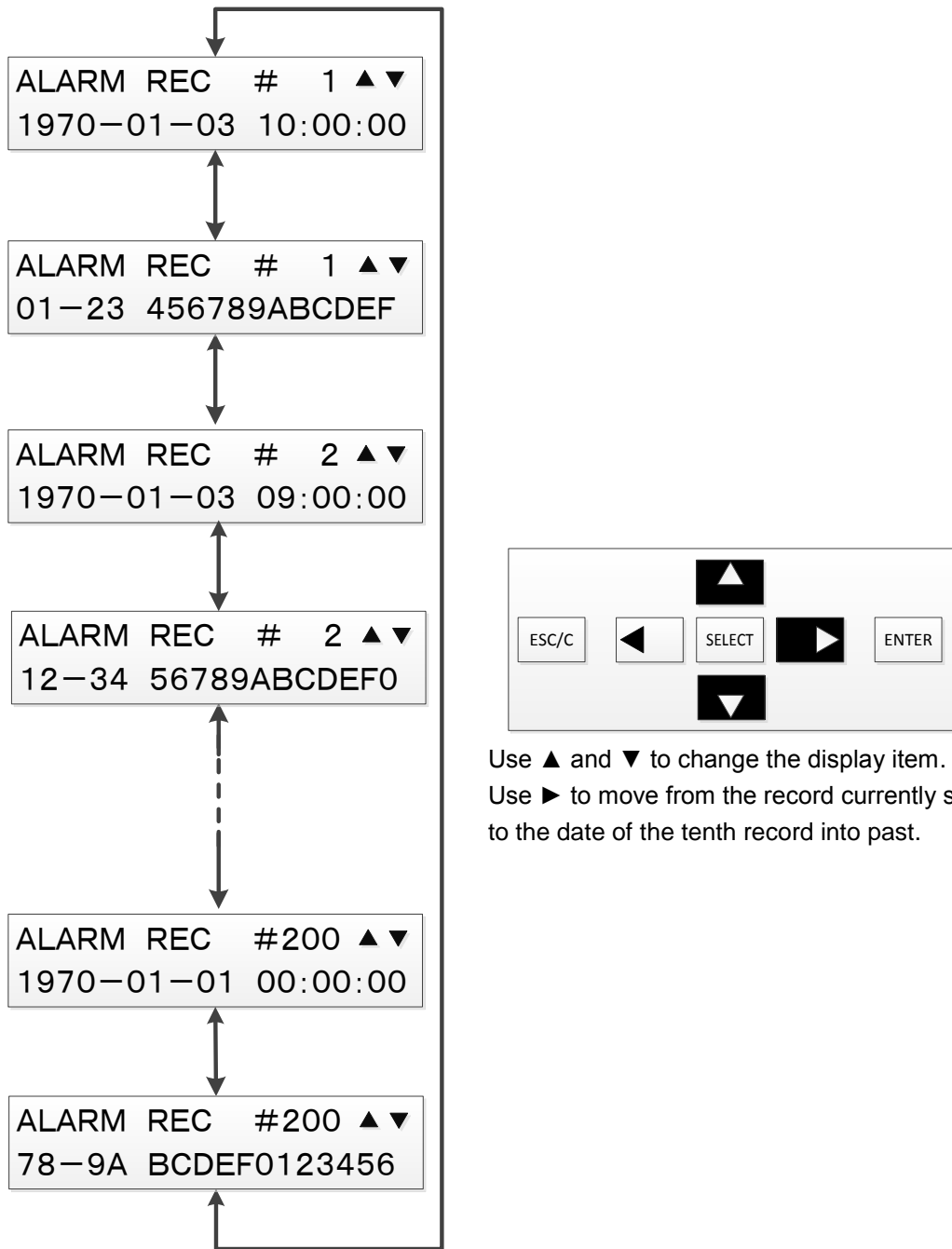

Use ▲ and ▼ to change the display item.  
Use ► to move from the record currently shown to the date of the tenth record into past.

Note: This is an example.

### 5.3.2.3. Setting (SETTING) menu

The Setting menu can be selected in either DISPLAY or SETTING mode but the DISPLAY mode only allows viewing of the setting values.

The setting values can be changed only in the SETTING mode.

For operations for the Setting menu, see 5.3.4.1.

### 5.3.2.4. Configuration (CONFIG) menu

The Configuration menu can be selected in either DISPLAY or SETTING mode. Clock adjustment (CLOCK ADJUST), Password use/unuse (PASSWORD USE) and Password registration (PASSWORD REGIST) can be selected only in the SETTING mode.

For other settings, the DISPLAY mode allows only viewing of the setting values.

The setting values can be changed only in the SETTING mode.

For operations for the Configuration menu, see 5.3.4.2.

### 5.3.3. Password input screen

If the password use/unuse setting is "USE," a four-digit password is requested when the SETTING mode is selected.

\* For the password use/unuse setting, see 5.3.4.2.6.

For how to set the password input, see 5.3.4.2.7.

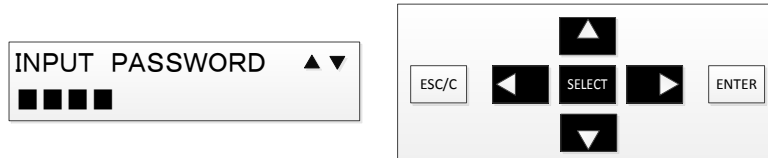

Use ▲ and ▼ to change the value of the each digit selected.  
Pressing SELECT confirms the value for the digit entered and moves the cursor to the next digit on the right.

If the password input is wrong, a screen as shown below appears.

PASSWORD INCORRECT  
TRY AGAIN

The main menu appears when the correct password has been input.

MAIN MENU ▲ ▼  
: SETTINGS

### 5.3.4. SETTING mode menu operations

This subsection describes the SETTING mode menu.

The menu screen has four selectable items. Use the Up and Down keys to select the item and press SELECT.

For the details about the menus available in the SETTING mode, see Table 5-2.

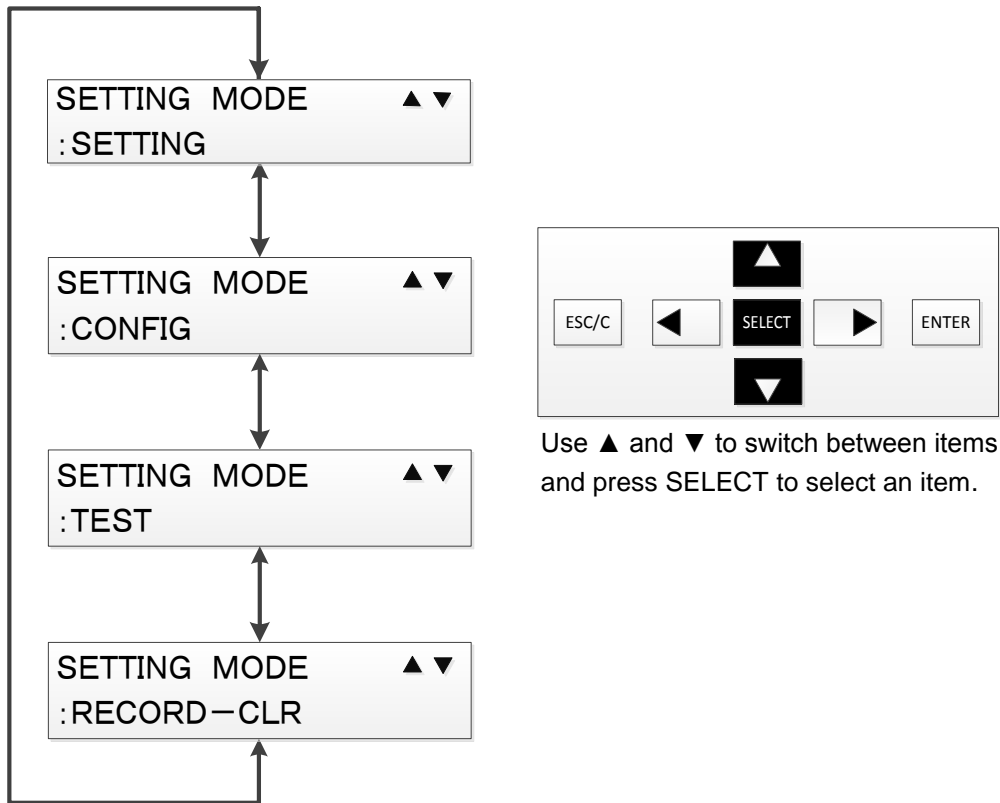

### 5.3.4.1. Setting (SETTING) menu

The Setting (SETTING) menu allows viewing/changing of the active setting group and viewing/changing of the group setting values.

The Setting menu can be selected in either DISPLAY or SETTING mode but the setting values can be changed only in the SETTING mode.

(The DISPLAY mode allows only viewing of the setting values.)

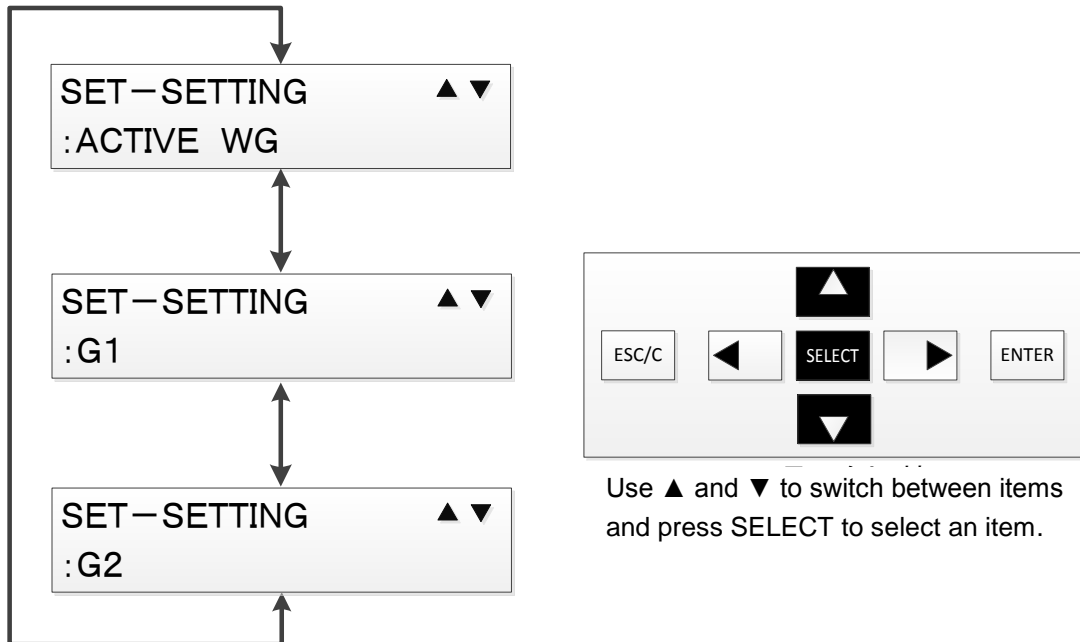

5.3.4.1.1. Active group (ACTIVE WG) menu

[Operation path] SETTING MODE > SETTING > ACTIVE WG

The Active group (ACTIVE WG) menu allows changing of the active group numbers setting. (Active group numbers can be changed only in the SETTING mode. The DISPLAY mode allows only viewing of the current group numbers.)



To change the active group number, in the Active group menu, press SELECT. A cursor appears, which allows the selection of a group number with the Up and Down keys. Select the group number to change and press SELECT to confirm the change.



Use ▲ and ▼ to switch between group Nos. and press SELECT to confirm the change

Press ENTER to show the confirmation screen below. Press SELECT to initiate the change to the group number selected.

When the new active group setting is not required, press the Left key to return the display back.

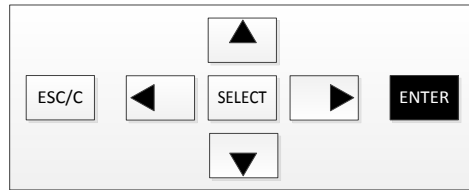

Press ENTER to show the screen on the left. ◦

The next message shows the Successful or Unsuccessful change of active group number. Pressing SELECT brings the display back to the Setting menu.



Message for a successful change of the active group



Message for an unsuccessful change of the active group

The cancel message will appear by pressing the Left key in the Active group menu. Pressing SELECT exits the Active group menu without changing the active group and brings the display back to the Setting menu.

Pressing the Left key brings the display back to the Active group menu.

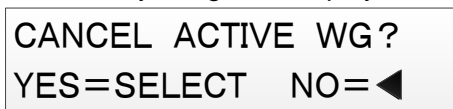

5.3.4.1.2. Group 1 setting (G1) and Group 2 setting (G2) menus

[Operation path] SETTING MODE > SETTING > G1(G2)

The Group 1 setting (G1) and Group 2 setting (G2) menus allow viewing and changing of the setting values for the respective group settings.

(Setting values can be changed only in the SETTING mode. The DISPLAY mode allows only viewing of the setting values)

The operation procedure for changing group settings is explained by changing G1 (for example).

1. First, select the setting value group in the Setting menu to change and press SELECT.



2. The Group setting menu appears.

Select the protective element to change with pressing the Up and Down key, and press SELECT.

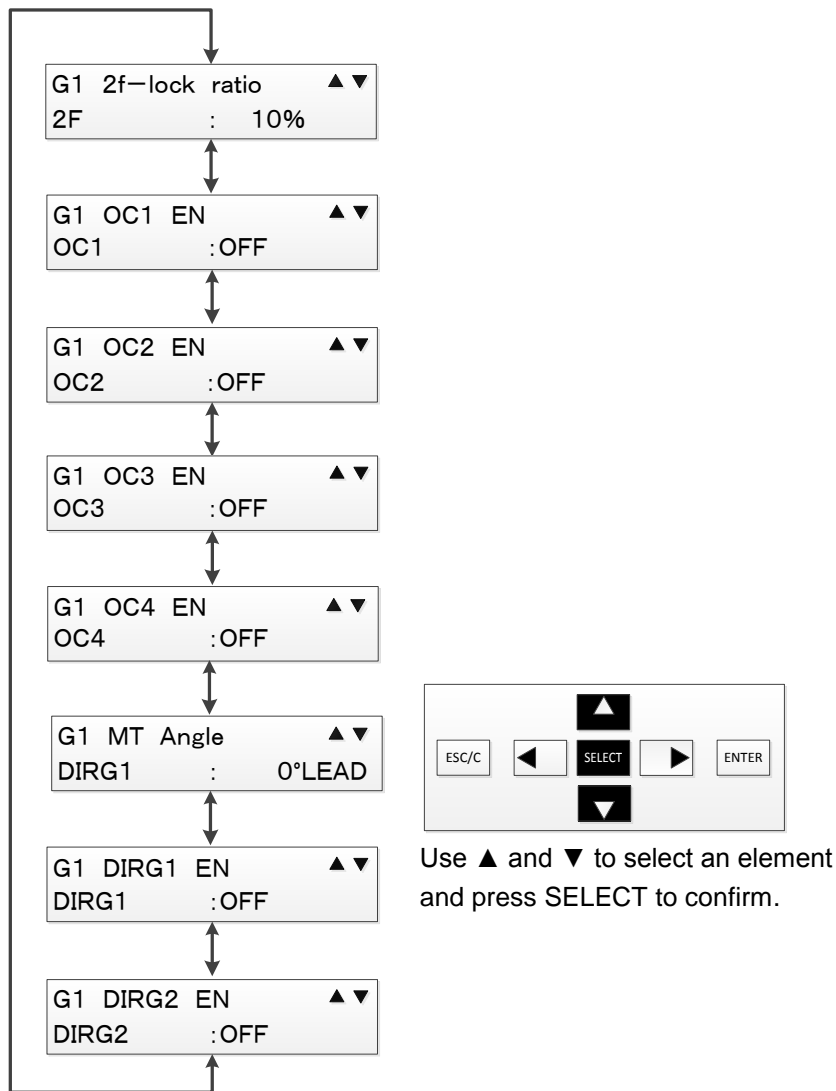

Note: This is an example.

3. The cursor moves to the setting parameter indication.

Use the Up and Down keys to select the setting parameter to be changed and press SELECT. The cursor moves to the setting value indication.

G1 ■f-lock ratio ▲▼  
2F : 10%

Cursor moves to the setting parameter indication.

G1 ■f-Min. Ope ▲▼  
2F : 0.4A

Select the setting parameter to change and press SELECT.

G1 1f-Min. Ope  
2F : ■.4A

Cursor moves to the setting value indication.

4. Use the Left and Right keys to select the digit to change and use the Up and Down keys to set the value.

G1 1f-Min. Ope  
2F : ■.4A

For setting a value as shown on the left, use ◀ and ▶ to select the digit to change, and ▲ and ▼ to set the value.

Press SELECT to confirm the change.

5. When the value has been changed, press SELECT to move the cursor to the setting parameter indication.

G1 ■f-Min. Ope ▲▼  
2F : 1.4A

Cursor moves to the setting parameter indication.

6. Complete setting of all parameters in the element to change by repeating steps 2 to 5 above.

7. Press the Left key to return the cursor back to the protective element indication.

Complete setting of any other protective elements to change by repeating steps 1 to 6 above.

G1 2f-lock ratio ▲▼  
■F : 20%

G1 OC1-EN ▲▼  
OC1 :OFF

8. When the all necessary change of the setting values has been completed, press ENTER.  
A confirmation message of the setting value changes appears as shown in the figure below. After confirmation of correct settings, press SELECT. If discarding the setting value changes, press the Left key.



CHANGE SETTING?  
YES=SELECT NO=◀

Press SELECT to change the setting.  
Press ◀ to discard the change.

The following messages are shown respectively to check the successful or unsuccessful setting change, The display returns back to the Setting menu by pressing SELECT while either of the messages below.



SETTING  
HAVE CHANGED

Message for successful  
changes of setting value



SETTING  
FAILED TO CHANGE

Message for unsuccessful  
changes of setting value

### 5.3.4.2. Configuration (CONFIG) menu

This subsection describes the operations for the Configuration (CONFIG) menu.

The Configuration menu can be selected in either DISPLAY or SETTING mode. Clock adjustment (CLOCK ADJUST), Password use/unuse (PASSWORD USE) and Password registration (PASSWORD REGIST) can be selected only in the SETTING mode.

The other settings can be changed in the SETTING mode only.  
(The DISPLAY mode only allows viewing of the setting values)

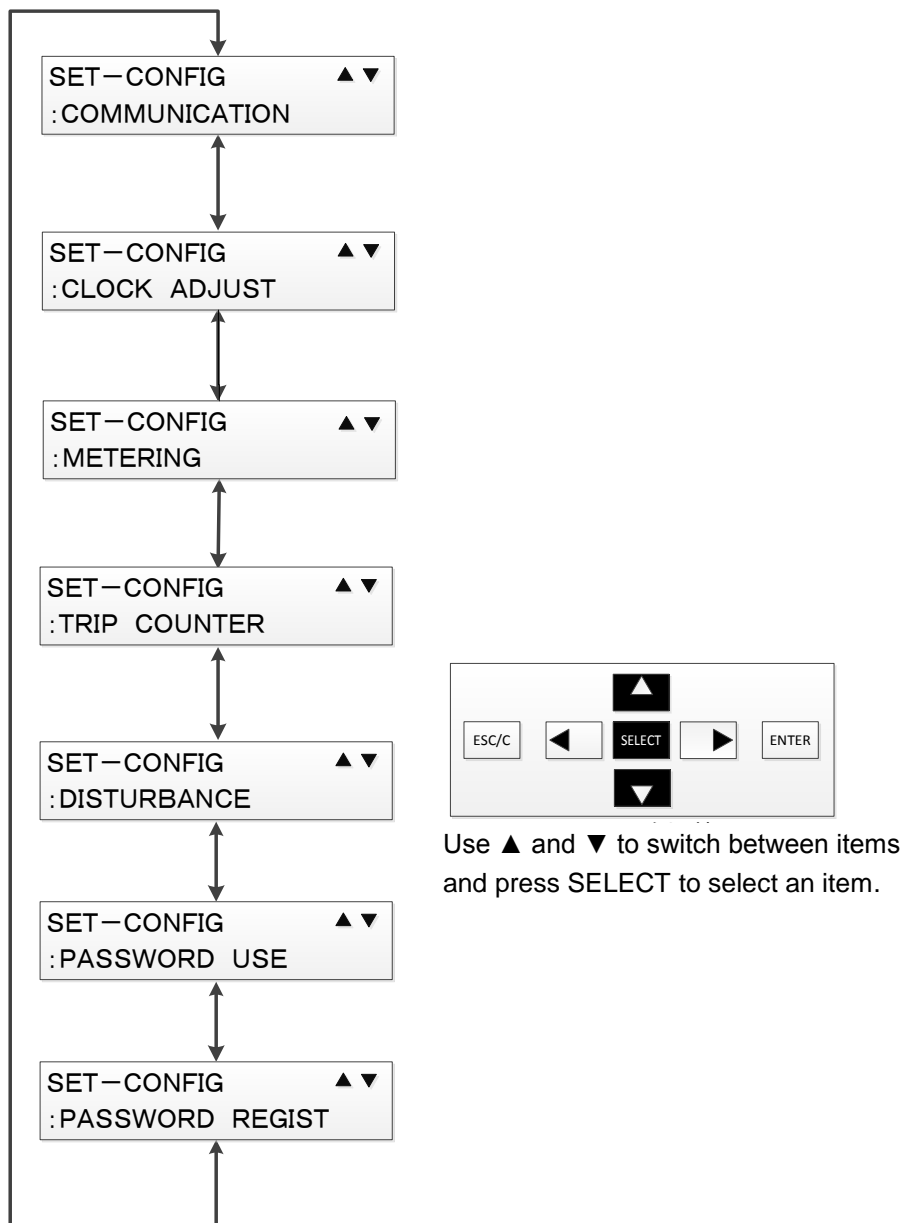

#### 5.3.4.2.1. Communication setting (COMMUNICATION) menu

[Operation path] SETTING MODE > CONFIG > COMMUNICATION

In regard to the standard products, there is no communication function.  
In this menu, the message "NONE" appears on the display.

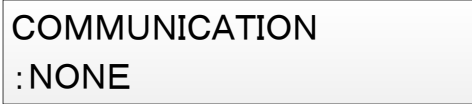

COMMUNICATION  
: NONE

5.3.4.2.2. Clock adjustment (CLOCK ADJUST) menu

[Operation path] SETTING MODE > CONFIG > CLOCK ADJUST

The Clock adjustment (CLOCK ADJUST) menu allows time setting. This item can be selected only in the SETTING mode.

1. When the Clock adjustment menu is selected, the current time is indicated as shown below. Pressing SELECT while this screen is shown allows changing of the year, month, day, hour, minute and second settings.

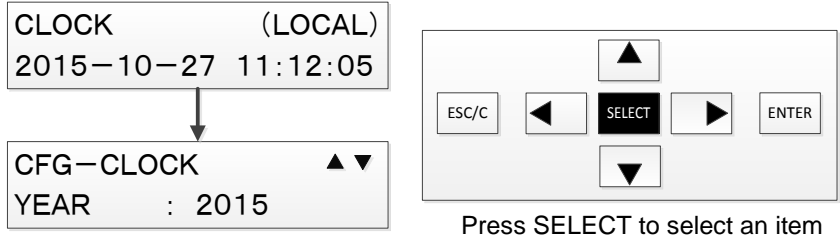

2. Pressing the Up and Down keys cycles through the year, month, day, hour, minute and second selection items. Select the item to change and press SELECT.

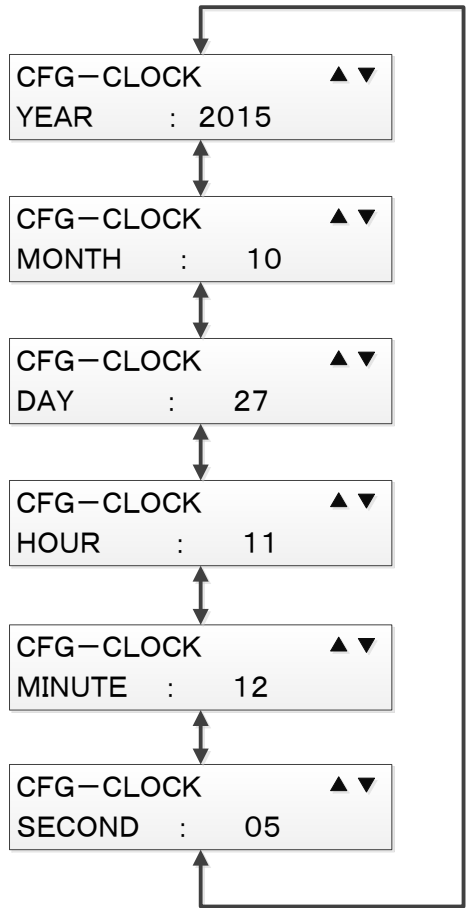

3. The cursor moves to the setting value. Use the Up and Down keys to select the value and the Left and Right keys to select the digit to make the change.



4. Press SELECT to change the setting value.

```
CFG-CLOCK ▲▼  
MONTH : 11
```

5. Complete setting of all other items to change by repeating steps 1. to 3..

6. Press ENTER and the confirmation message of the time setting appears.

Press SELECT to apply the time setting changed by steps 1. to 4. and complete the Clock adjustment setting.

Press the Left key to go back to the Clock adjustment menu without applying the setting changes.

```
CHANGE SETTING?  
YES=SELECT NO=◀
```

### 5.3.4.2.3. Analog value display switching (METERING) menu

[Operation path] SETTING MODE > CONFIG > METERING

The Analog value display switching (METERING) menu allows configuration of the following settings.

- (1) Set the indication type from the primary or secondary side of CT/VT
- (2) Set the rating of CT/VT.

(The DISPLAY mode only allows viewing of the setting values)

The following describes the operation procedure for viewing and changing the settings for the Measurement value display switching menu.

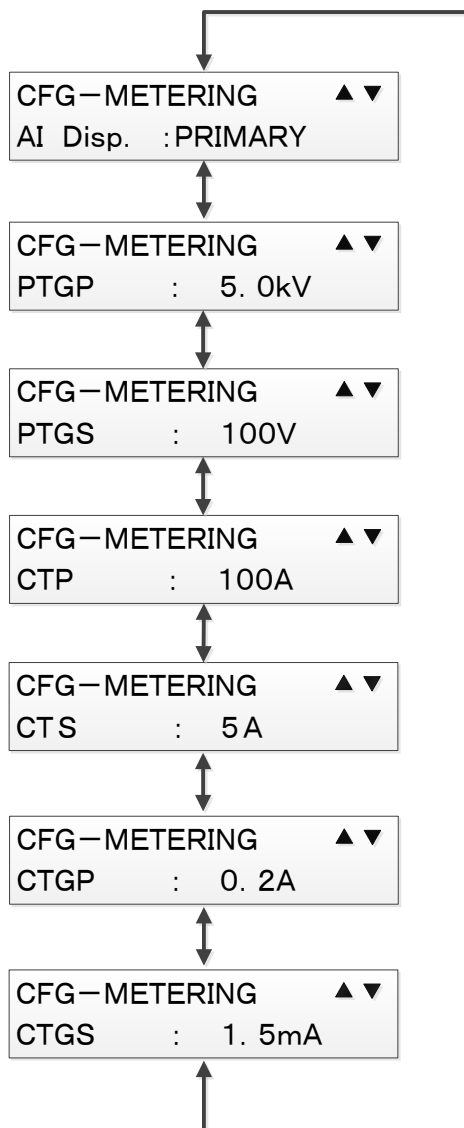

Note: This is an example.

1. Use the Up and Down keys to select the item to change and press SELECT for selection.

```
CFG—METERING ▲▼
AI Disp. : PRIMARY
```

2. The cursor moves to the setting value. Use the Up and Down keys to select the value and the Left and Right keys to select the digit to make the change.

3. Press SELECT to change the setting value.

4. Complete setting of all other items to change by repeating steps 1. to 3..

5. Press ENTER and the confirmation message of the new measurement settings appears as shown in the figure below.

Press SELECT to apply the measurement value settings changed by steps 1. to 4. and complete the setting.

Press the Left key to go back to the Analog value display switching menu without applying the setting changes.

```
CHANGE SETTING?
YES=SELECT NO=◀
```

**Table 5-11 Setting items of analog value display**

• CFP1-A42D1

No.	Item	Setting description	Setting range	Unit
1	AI Disp	AI display primary value / secondary value selection	PRIMARY / SECONDARY	—
2	PTGP	EVT primary side rating	0.10 ~ 99.00	kV
3	PTGS	EVT tertiary side rating	100 ~ 220	V
4	CTP	CT primary side rating	5 ~ 30000	A
5	CTS	CT secondary side rating	1, 5	A
6	CTGP	Zero-sequence current primary side rating	0.1 ~ 100.0	A
7	CTGS	Zero-sequence current secondary side rating	1.5 / 1, 5	mA A

• CFP1-A43D1

No.	Item	Setting description	Setting range	Unit
1	AI Disp	AI display primary value / secondary value selection	PRIMARY / SECONDARY	—
2	PTGP	EVT primary side rating	0.10 ~ 99.00	kV
3	PTGS	EVT tertiary side rating	100 ~ 220	V
4	CTP	CT primary side rating	5 ~ 30000	A
5	CTS	CT secondary side rating	1, 5	A
6	CTGP	Zero-sequence current primary side rating	5 ~ 30000	A
7	CTGS	Zero-sequence current secondary side rating	1, 5	A

5.3.4.2.4. Trip counter (TRIP COUNTER) menu

[Operation path] SETTING MODE > CONFIG > TRIP COUNTER

The Trip counter (TRIP COUNTER) menu allows setting of the initial counter and alarm counter values. The trip counter will count the number of trip times.

(The DISPLAY mode only allows viewing of the setting values)

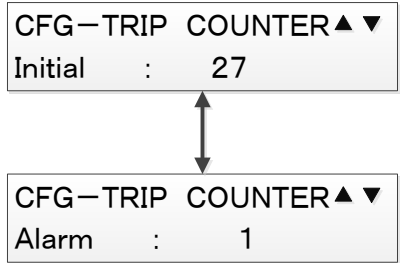

1. The trip counter setting menu appears. Use the Up and Down keys to select the item to change and press SELECT.

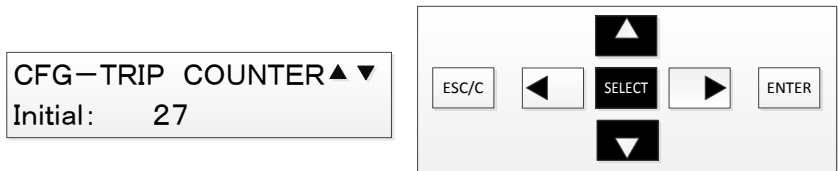

Use ▲ and ▼ to switch between items and press SELECT to select an item.

2. The cursor moves to the setting value. Use the Up and Down keys to select the value and the Left and Right keys to select the digit to make the change.



3. Press SELECT to change the setting value.



4. Complete setting of all other items to change by repeating steps 1. to 3..
5. Press ENTER and the confirmation message of the trip counter settings appears. Press SELECT to apply the trip counter settings changed by steps 1. to 4. and complete the setting. Press the Left key to go back to the setting menu in step 1. above without applying the setting changes.

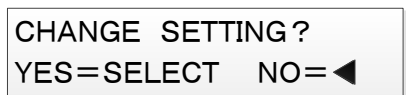

**Table 5-12 Setting items of trip counter**

No.	Item	Setting description	Setting range	Unit
1	Initial	Initial value of trip counter	0~10000	Times
2	Alarm	Alarm value of trip counter	1~10000	Times

5.3.4.2.5. Disturbance record (DISTURBANCE) menu

[Operation path] SETTING MODE > CONFIG > DISTURBANCE

The Disturbance record (DISTURBANCE) menu allows setting of maximum recording time and pre-fault recording time of each disturbance (fault) record.

(The DISPLAY mode only allows viewing of the setting values)

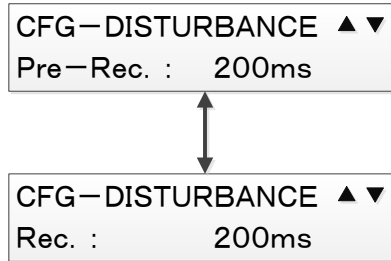

1. Use the Up and Down keys to select the item to change and press SELECT.

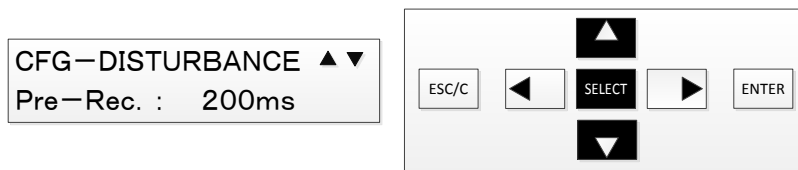

Use ▲ and ▼ to switch between items and press SELECT to select an item.

2. The cursor moves to the setting value. Use the Up and Down keys to select the value and the Left and Right keys to select the digit to make the change.



3. Press SELECT to change the setting value.

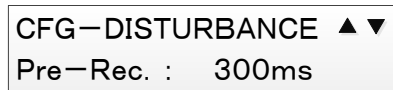

4. Complete setting of all other items to change by repeating steps 1. to 3..

5. Press ENTER and the message to confirm application of the disturbance record time settings appears. Press SELECT to apply the disturbance record time settings changed by steps 1. to 4. and complete the setting.

Press the Left key to go back to the setting menu in step 1. above without applying the setting changes.



**Table 5-13 Setting items of disturbance record time**

No.	Item	Setting description	Setting range	Unit
1	Pre-Rec.	Save time of pre-fault waveform data	100 ~ 4500	ms
2	Rec.	Save time of waveform data	200 ~ 5000	ms

Note: The save time of “PRE TIME” is included in that of “REC TIME”.

In other words, the setting value of “REC TIME” must be larger than that of “PRE TIME”.

5.3.4.2.6. Password use/unuse (PASSWORD USE) menu

[Operation path] SETTING MODE > CONFIG > PASSWORD USE

The Password use/unuse (PASSWORD USE) menu specifies whether to use or not use a password input when the SETTING mode is selected.

(This item is not shown in the DISPLAY mode)

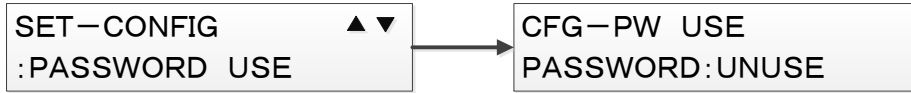

1. In the Password use/unuse menu, press SELECT.

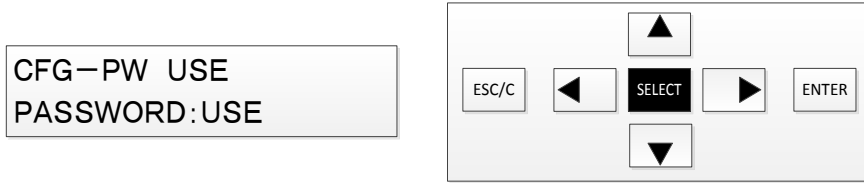

Press SELECT to select an item

2. The cursor moves to the setting value. Use the Up and Down keys to select the setting to be changed.

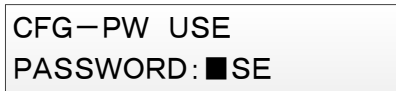

3. Press SELECT to change the setting value.



4. Press ENTER and the confirmation message of the password use/unuse setting changed appears as shown in the figure below.

Press SELECT to apply the password use/unuse setting and complete the setting.

Press the Left key to go back to the setting menu in step 1. above without applying the setting changes.

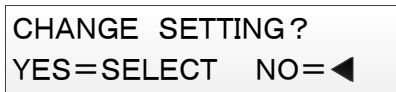

**Table 5-14 Setting item of Password use/unuse**

No.	Item	Setting description	Setting
1	PASSWORD	Password use/unuse setting	USE / UNUSE

5.3.4.2.7. Password registration (PASSWORD REGIST) menu

[Operation path] SETTING MODE > CONFIG > PASSWORD REGIST

The Password registration (PASSWORD REGIST) menu allows the setting of the password input when the SETTING mode is selected.

(This item is not shown in the DISPLAY mode)

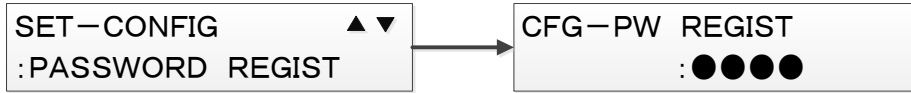

1. In the Password registration menu, press SELECT.

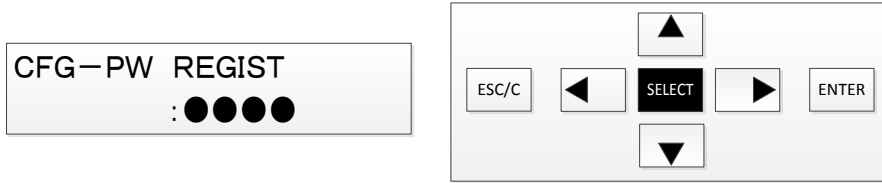

Press SELECT to select an item

2. The Password registration screen appears.

For registering a password, press SELECT after each digit is entered. Pressing SELECT confirms the value for the digit entered and moves the cursor to the digit on the right. It is not possible to return to the previous digit by using the Left key. Use the Up and Down keys to select a value out of 0 to 9 for each digit.



3. When the four digits have been entered, password input is requested again.

Enter the same password as that registered in step 2 above.

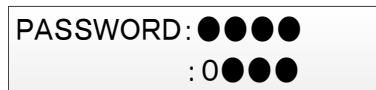

4. If the above two password-inputs in steps 2 and 3 are same, the screen shown in step 1 appears.

Press ENTER and the confirmation message of the password registration appears. Press SELECT to apply the password registration and complete the setting. Press the Left key to go back to the setting menu in step 1. above without applying the setting changes.

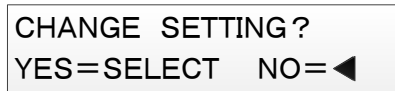

If the two password-inputs in steps 2 and 3 are not same, an error message as shown below appears.

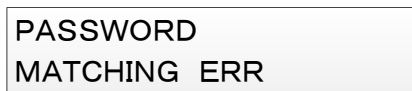

### 5.3.4.3. TEST menu

This subsection describes the operations for the Test menu.  
The Test menu can be selected only in the SETTING mode.

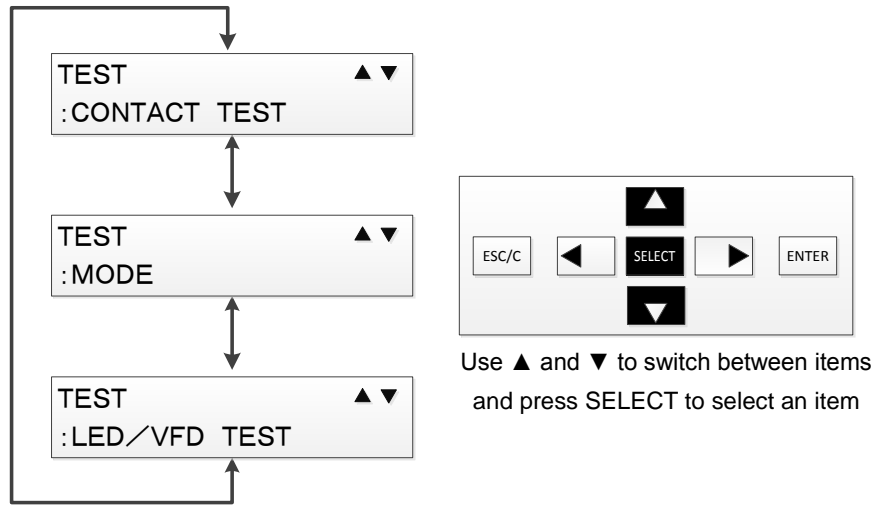

#### 5.3.4.3.1. DO contact test (CONTACT TEST) menu

[Operation path] SETTING MODE > TEST > CONTACT TEST

The DO contact test (CONTACT TEST) menu allows contact testing of DO signals (DO1 to DO8).

1. When the DO contact test menu has been selected, the caution message appears.

```
TRP-CIRCUIT BLOCK?
YES=SELECT NO=<
```

When pressing SELECT, the next message appears. Then, press "SELECT" again.

```
AFTER SPECIFYING.
PRESS 'ENTER'
```

2. The setting screen for the DO contact test appears.  
Use the Up and Down keys to select the item to set and press SELECT.

```
CONTACT TEST ▲▼
DO1-T : OFF
```

3. The cursor moves to the setting of the selected item.  
 Use the Up and Down keys to switch the setting.  
 Select ON to conduct a contact test on the selected DO. If not, select OFF.

CONTACT TEST	▲▼
DO1-T	: ■ FF

4. Press SELECT to change the setting and bring the cursor back to the item name.

CONTACT TEST	▲▼
DO1-T	: ON

5. Complete settings of all the items to change by repeating steps 2. to 4. above.
6. After the settings are completed, press ENTER while the setting item selection screen in step 4 is shown in order to operate DO contact test.  
 \*The selected DO contact(s) is(are) operated while ENTER is held down. The operation of the respective DO contact corresponds to the settings in steps (2) to (5) above.

To exit the DO contact test setting screen, press the Left key.

**Table 5-15 Setting items of DO contact test**

No.	Item
1	DO1-T
2	DO2-T
3	DO3-T
4	DO4-T
5	DO5-T
6	DO6-T
7	DO7-T
8	DO8-T

5.3.4.3.2. Test mode (MODE) menu

[Operation path] SETTING MODE > TEST > MODE

The Test mode (MODE) menu allows setting of the test mode.

1. Use the Up and Down keys to select the item to set and press SELECT.

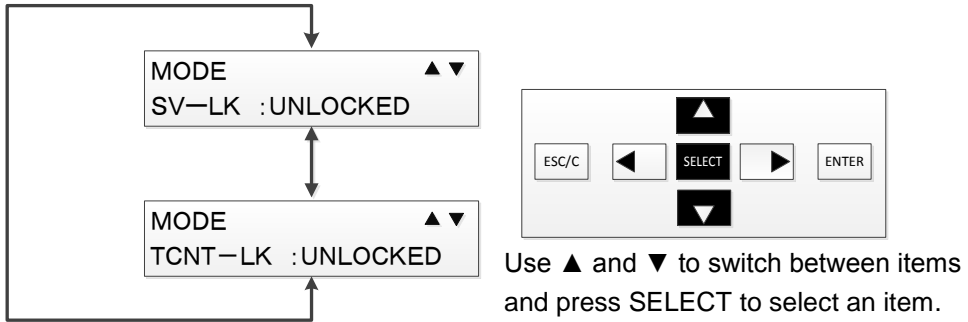

2. The cursor moves to the setting of the selected item. Use the Up and Down keys to switch the setting.



3. Press SELECT to change the setting.



4. Complete setting of all other items to change by repeating steps 1. to 3. above.
5. Press ENTER to be enable the test mode as set in steps 1. to 4. above.  
The RUN LED flashes during the test mode.

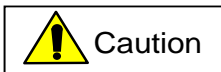

**During the test mode, use of the Left or ESC key to exit the SETTING mode is disabled.  
(Operations implemented in the SETTING mode are enabled)  
When turning off the VFD screen or moving to the DISPLAY mode, it exits the test mode.**

#### 5.3.4.3.3. LED/VFD lighting test (LED/VFD TEST) menu

[Operation path] SETTING MODE > TEST > LED/VFD TEST

The LED/VFD lighting test (LED/VFD TEST) menu allows lighting of all LEDs/VFDs.

When LED/VFD TEST is selected in the Test menu, a screen as shown below appears.

Pressing ENTER and all LEDs and VFDs are lighting while the key is held down.

It can be checked the LED/VFD indication visually.



LED/VFD TEST  
PREESS 'ENTER'

### 5.3.4.4. Clear record (RECORD-CLR) menu

The Clear record (RECORD-CLR) menu allows clearing three types of log data: fault, event and alarm records.

\*Access record log data cannot be cleared.

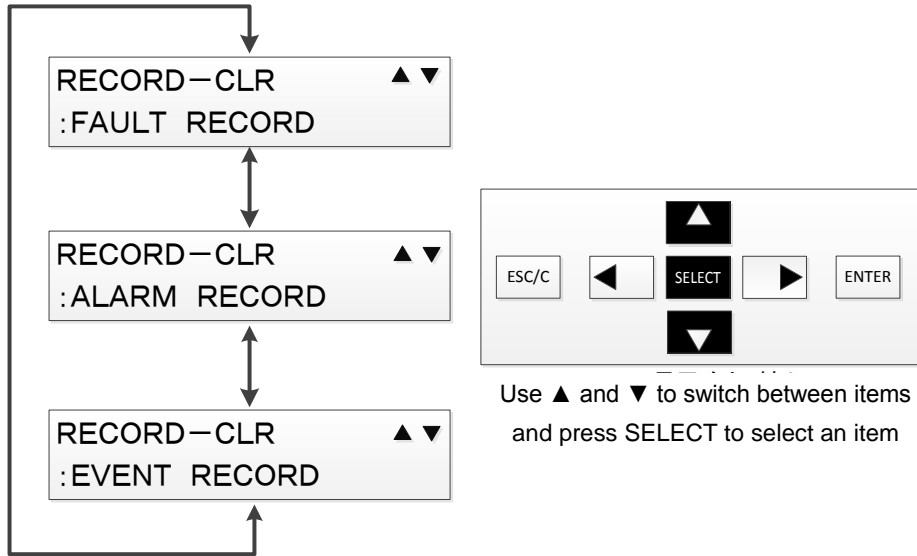

#### 5.3.4.4.1. Clear fault record (FAULT REC CLEAR) menu

[Operation path] SETTING MODE > RECORD-CLR > FAULT RECORD

The Clear fault record (FAULT REC CLEAR) menu allows clearing of fault records. In the Clear record menu, select FAULT RECORD and press ENTER. Then, the next screen appears. Press SELECT to clear the fault records. When pressing the Left key, the display returns to the selection screen of Clear record menu without clearing the fault records.



When clearing of the fault records are completed, the display returns to the Clear record menu. If the clearing is unsuccessful, a message screen as shown below appears. Pressing SELECT while the message below is shown brings the display back to the Clear record menu selection screen.

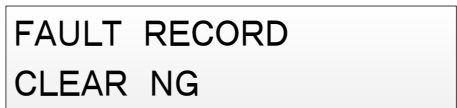

#### 5.3.4.4.2. Clear alarm record (ALARM REC CLEAR) menu

[Operation path] SETTING MODE > RECORD-CLR > ALARM RECORD

The Clear alarm record (ALARM REC CLEAR) menu allows clearing of alarm records. In the Clear record menu, select ALARM RECORD and press ENTER. Then, the next screen appears. Press SELECT to clear the alarm records. When pressing the Left key, the display returns to the selection screen of Clear record menu without clearing the alarm records.



ALARM REC CLEAR?  
YES=SELECT NO=<

When clearing of the alarm records are completed, the display returns to the Clear record menu. If the clearing is unsuccessful, a message screen as shown below appears. Pressing SELECT while the message below is shown brings the display back to the Clear record menu selection screen.

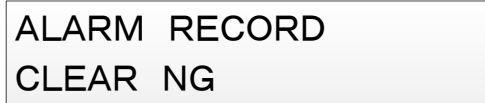

ALARM RECORD  
CLEAR NG

#### 5.3.4.4.3. Clear event record (EVENT REC CLEAR) menu

[Operation path] SETTING MODE > RECORD-CLR > EVENT RECORD

The Clear event record (EVENT REC CLEAR) menu allows clearing of event records. In the Clear record menu, select EVENT RECORD and press ENTER. Then, the next screen appears. Press SELECT to clear the event records. When pressing the Left key, the display returns to the selection screen of Clear record menu without clearing the event records.

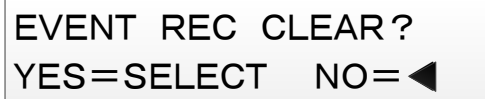

EVENT REC CLEAR?  
YES=SELECT NO=<

When clearing of the event records are completed, the display returns to the Clear record menu. If the clearing is unsuccessful, a message screen as shown below appears. Pressing SELECT while the message below is shown brings the display back to the Clear record menu selection screen.

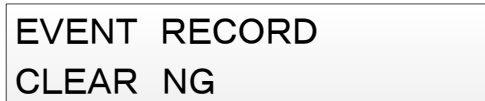

EVENT RECORD  
CLEAR NG

## 6. PC-HMI

PC-HMI is a software for setting, configuration, and supervision of this relay.

The software can be downloaded on the web site of Mitsubishi Electric FA (Factory Automation).

The operation method is described in a separate volume. Please refer to the following document.

Title of document	Document No.
MELPRO-D Series Protection Relay PC-HMI Instruction Manual	JEP0-IL9504

In regard to PLC signals, refer to Table 6-1 and Table 6-2.

**Table 6-1 PLC signals of CFP1-A42D1**

Signal name	Description
OC1-A/	Definitive signal of 1st instantaneous overcurrent (50) element on A phase
OC1-C/	Definitive signal of 1st instantaneous overcurrent (50) element on C phase
OC2-A/	Definitive signal of 2nd instantaneous overcurrent (50) element on A phase
OC2-C/	Definitive signal of 2nd instantaneous overcurrent (50) element on C phase
OC3-A/	Definitive signal of 3rd instantaneous overcurrent (50) element on A phase
OC3-C/	Definitive signal of 3rd instantaneous overcurrent (50) element on C phase
OC4-A/	Definitive signal of definite time or IDMT overcurrent (51) element on A phase
OC4-C/	Definitive signal of definite time or IDMT overcurrent (51) element on C phase
DIRG1/	Definitive signal of 1st directional ground fault (67G) element
DIRG2/	Definitive signal of 2nd directional ground fault (67G) element
TCNT_ALM	Alarm of trip counter
OC1-AD	Detection signal of 1st instantaneous overcurrent (50) element on A phase
OC1-CD	Detection signal of 1st instantaneous overcurrent (50) element on C phase
OC2-AD	Detection signal of 2nd instantaneous overcurrent (50) element on A phase
OC2-CD	Detection signal of 2nd instantaneous overcurrent (50) element on C phase
OC3-AD	Detection signal of 3rd instantaneous overcurrent (50) element on A phase
OC3-CD	Detection signal of 3rd instantaneous overcurrent (50) element on C phase
OC4-AD	Detection signal of definite time or IDMT overcurrent (51) element on A phase
OC4-CD	Detection signal of definite time or IDMT overcurrent (51) element on C phase
DIRG1-D	Detection signal of 1st directional ground fault (67G) element
DIRG2-D	Detection signal of 2nd directional ground fault (67G) element
2f-AD	Detection signal of 2f on A phase
2f-CD	Detection signal of 2f on C phase
ALARM	Abnormal condition of constant supervision (serious failure)
ALARM-L	Abnormal condition of constant supervision (minor failure)
RY-LOCK	Locking of relay
RESET	Reset signal (activated by pushing ESC/C button for more than 3 seconds)
INTER1	1st intermediate output signal of PLC
INTER2	2nd intermediate output signal of PLC
INTER3	3rd intermediate output signal of PLC
INTER4	4th intermediate output signal of PLC
INTER5	5th intermediate output signal of PLC
INTER6	6th intermediate output signal of PLC
INTER7	7th intermediate output signal of PLC
INTER8	8th intermediate output signal of PLC
OC1-3D_O	Detection signal of any OC1 of A and C phase
OC2-3D_O	Detection signal of any OC2 of A and C phase
OC3-3D_O	Detection signal of any OC3 of A and C phase
OC4-3D_O	Detection signal of any OC4 of A and C phase
2f-3D_O	Detection signal of any 2f of A and C phase
HOC-AD_O	Detection signal of any of OC1, OC2, and OC3 on A phase
HOC-CD_O	Detection signal of any of OC1, OC2, and OC3 on C phase
HOC-3D_O	Detection signal of any of OC1, OC2, and OC3 on A and C phase (OR of all instantaneous overcurrent elements)
OC-3D_O	Detection signal of any of overcurrent elements on A and C phase
DIRG-D_O	Detection signal of DIRG1 or DIRG2 elements

ALLEL-D_O	Detection signal of any of all elements (OR of all detection signals)
OC1-3_O/	Definitive signal of any OC1 of A and C phase
OC2-3_O/	Definitive signal of any OC2 of A and C phase
OC3-3_O/	Definitive signal of any OC3 of A and C phase
OC4-3_O/	Definitive signal of any OC4 of A and C phase
HOC-A_O/	Definitive signal of any of OC1, OC2, and OC3 on A phase
HOC-C_O/	Definitive signal of any of OC1, OC2, and OC3 on C phase
HOC-3_O/	Definitive signal of any of OC1, OC2, and OC3 on A and C phase (OR of all instantaneous overcurrent elements)
OC-3_O	Definitive signal of any of overcurrent elements on A and C phase
DIRG-O	Definitive signal of DIRG1 or DIRG2 elements
ALLEL-O	Definitive signal of any of all elements (OR of all definitive signals)
OC1-A	Definitive signal of OC1 A-phase or forced operation from PC-HMI
OC1-C	Definitive signal of OC1 C-phase or forced operation from PC-HMI
OC2-A	Definitive signal of OC2 A-phase or forced operation from PC-HMI
OC2-C	Definitive signal of OC2 C-phase or forced operation from PC-HMI
OC3-A	Definitive signal of OC3 A-phase or forced operation from PC-HMI
OC3-C	Definitive signal of OC3 C-phase or forced operation from PC-HMI
OC4-A	Definitive signal of OC4 A-phase or forced operation from PC-HMI
OC4-C	Definitive signal of OC4 C-phase or forced operation from PC-HMI
OC4-3_O	Definitive signal of any OC4 of A and C phase or forced operation from PC-HMI
DIRG1	Definitive signal of DIRG1 or forced operation from PC-HMI
DIRG2	Definitive signal of DIRG2 or forced operation from PC-HMI
HOC-A_O	Definitive signal of any of instantaneous elements on A phase or forced operation from PC-HMI
HOC-C_O	Definitive signal of any of instantaneous elements on C phase or forced operation from PC-HMI
HOC-3_O	Definitive signal of any of instantaneous elements on A and C phase or forced operation from PC-HMI

**Table 6-2 PLC signals of CFP1-A43D1**

Signal name	Description
OC1-A/	Definitive signal of 1st instantaneous overcurrent (50) element on A phase
OC1-B/	Definitive signal of 1st instantaneous overcurrent (50) element on B phase
OC1-C/	Definitive signal of 1st instantaneous overcurrent (50) element on C phase
OC2-A/	Definitive signal of 2nd instantaneous overcurrent (50) element on A phase
OC2-B/	Definitive signal of 2nd instantaneous overcurrent (50) element on B phase
OC2-C/	Definitive signal of 2nd instantaneous overcurrent (50) element on C phase
OC3-A/	Definitive signal of 3rd instantaneous overcurrent (50) element on A phase
OC3-B/	Definitive signal of 3rd instantaneous overcurrent (50) element on B phase
OC3-C/	Definitive signal of 3rd instantaneous overcurrent (50) element on C phase
OC4-A/	Definitive signal of definite time or IDMT overcurrent (51) element on A phase
OC4-B/	Definitive signal of definite time or IDMT overcurrent (51) element on B phase
OC4-C/	Definitive signal of definite time or IDMT overcurrent (51) element on C phase
DIRG1/	Definitive signal of 1st directional ground fault (67G) element
DIRG2/	Definitive signal of 2nd directional ground fault (67G) element
TCNT_ALM	Alarm of trip counter
OC1-AD	Detection signal of 1st instantaneous overcurrent (50) element on A phase
OC1-BD	Detection signal of 1st instantaneous overcurrent (50) element on B phase
OC1-CD	Detection signal of 1st instantaneous overcurrent (50) element on C phase
OC2-AD	Detection signal of 2nd instantaneous overcurrent (50) element on A phase
OC2-BD	Detection signal of 2nd instantaneous overcurrent (50) element on B phase
OC2-CD	Detection signal of 2nd instantaneous overcurrent (50) element on C phase
OC3-AD	Detection signal of 3rd instantaneous overcurrent (50) element on A phase
OC3-BD	Detection signal of 3rd instantaneous overcurrent (50) element on B phase
OC3-CD	Detection signal of 3rd instantaneous overcurrent (50) element on C phase
OC4-AD	Detection signal of definite time or IDMT overcurrent (51) element on A phase
OC4-BD	Detection signal of definite time or IDMT overcurrent (51) element on B phase
OC4-CD	Detection signal of definite time or IDMT overcurrent (51) element on C phase
DIRG1-D	Detection signal of 1st directional ground fault (67G) element
DIRG2-D	Detection signal of 2nd directional ground fault (67G) element
2f-AD	Detection signal of 2f on A phase
2f-BD	Detection signal of 2f on B phase
2f-CD	Detection signal of 2f on C phase
ALARM	Abnormal condition of constant supervision (serious failure)
ALARM-L	Abnormal condition of constant supervision (minor failure)
RY-LOCK	Locking of relay
RESET	Reset signal (activated by pushing ESC/C button for more than 3 seconds)
INTER1	1st intermediate output signal of PLC
INTER2	2nd intermediate output signal of PLC
INTER3	3rd intermediate output signal of PLC
INTER4	4th intermediate output signal of PLC
INTER5	5th intermediate output signal of PLC
INTER6	6th intermediate output signal of PLC
INTER7	7th intermediate output signal of PLC
INTER8	8th intermediate output signal of PLC
OC1-3D_O	Detection signal of any OC1 of A, B, and C phase
OC2-3D_O	Detection signal of any OC2 of A, B, and C phase

OC3-3D_O	Detection signal of any OC3 of A, B, and C phase
OC4-3D_O	Detection signal of any OC4 of A, B, and C phase
2f-3D_O	Detection signal of any 2f of A, B, and C phase
HOC-AD_O	Detection signal of any of OC1, OC2, and OC3 on A phase
HOC-BD_O	Detection signal of any of OC1, OC2, and OC3 on B phase
HOC-CD_O	Detection signal of any of OC1, OC2, and OC3 on C phase
HOC-3D_O	Detection signal of any of OC1, OC2, and OC3 on all phase (OR of all instantaneous overcurrent elements)
OC-3D_O	Detection signal of any of overcurrent elements on A, B, and C phase
DIRG-D_O	Detection signal of DIRG1 or DIRG2 elements
ALLEL-D_O	Detection signal of any of all elements (OR of all detection signals)
OC1-3_O/	Definitive signal of any OC1 of A, B, and C phase
OC2-3_O/	Definitive signal of any OC2 of A, B, and C phase
OC3-3_O/	Definitive signal of any OC3 of A, B, and C phase
OC4-3_O/	Definitive signal of any OC4 of A, B, and C phase
HOC-A_O/	Definitive signal of any of OC1, OC2, and OC3 on A phase
HOC-B_O/	Definitive signal of any of OC1, OC2, and OC3 on B phase
HOC-C_O/	Definitive signal of any of OC1, OC2, and OC3 on C phase
HOC-3_O/	Definitive signal of any of OC1, OC2, and OC3 on all phase (OR of all instantaneous overcurrent elements)
OC-3_O	Definitive signal of any of overcurrent elements on A, B, and C phase
DIRG-O	Definitive signal of DIRG1 or DIRG2 elements
ALLEL-O	Definitive signal of any of all elements (OR of all definitive signals)
OC1-A	Definitive signal of OC1 A-phase or forced operation from PC-HMI
OC1-B	Definitive signal of OC1 B-phase or forced operation from PC-HMI
OC1-C	Definitive signal of OC1 C-phase or forced operation from PC-HMI
OC2-A	Definitive signal of OC2 A-phase or forced operation from PC-HMI
OC2-B	Definitive signal of OC2 B-phase or forced operation from PC-HMI
OC2-C	Definitive signal of OC2 C-phase or forced operation from PC-HMI
OC3-A	Definitive signal of OC3 A-phase or forced operation from PC-HMI
OC3-B	Definitive signal of OC3 B-phase or forced operation from PC-HMI
OC3-C	Definitive signal of OC3 C-phase or forced operation from PC-HMI
OC4-A	Definitive signal of OC4 A-phase or forced operation from PC-HMI
OC4-B	Definitive signal of OC4 B-phase or forced operation from PC-HMI
OC4-C	Definitive signal of OC4 C-phase or forced operation from PC-HMI
OC4-3_O	Definitive signal of any OC4 of A, B, and C phase or forced operation from PC-HMI
DIRG1	Definitive signal of DIRG1 or forced operation from PC-HMI
DIRG2	Definitive signal of DIRG2 or forced operation from PC-HMI
HOC-A_O	Definitive signal of any of instantaneous elements on A phase or forced operation from PC-HMI
HOC-B_O	Definitive signal of any of instantaneous elements on B phase or forced operation from PC-HMI
HOC-C_O	Definitive signal of any of instantaneous elements on C phase or forced operation from PC-HMI
HOC-3_O	Definitive signal of any of instantaneous elements on all phase or forced operation from PC-HMI

## 7. Rating, Specification

### 7.1. Features

#### (1) Multi-function

- The relay incorporates a variety of protection functions which are required for feeder protection.
- The relay has two Group settings sets. Therefore, it can be used for different purposes, such as operation/test, or quickly adapted to meet load conditions.
- Control of a circuit breaker is possible via the front panel, PC-HMI, or remote communication (option).

#### (2) High-precision measuring functions

- Measurement functions are enhanced.  
Measurement values (e.g. current and voltage) can be viewed via the front panel display on the relay or using interface software on a PC.  
In addition, you can expand the character size of the measured values on the front panel display, which enables to check values easily.
- Fault / Disturbance Recording  
The relay stores up to 5 fault / disturbance records which can be used for fault investigations. Fault record function is the record of analog input values (as RMS) at the time when relay elements are operated. Disturbance record function is the record of waveform data for the prescribed period before and after occurrence of fault at sampling rate of 24 samples/cycle.

#### (3) Diverse operation and reset time characteristics

The relay incorporates various operation and reset time characteristics, which enables suitable protection coordination.

#### (4) Programmable Output Contacts provide flexibility

The configuration of output contact is possible by PLC (Programmable Logic Controller), which enables to apply the relay to various systems.

#### (5) Advanced constant monitoring function improves reliability

The relay continuously monitors the electronic circuits and can detect internal component failure, which enables to improve reliability.

The relay's behavior is as follows:

- In normal conditions: RUN LED lights.
- In abnormal conditions: ALARM LED lights.

During serious abnormal conditions, the protection elements are locked to prevent an unnecessary output, and the relay fail alarm is issued.

#### (6) The draw-out Subunit improves maintainability

The provision of an automatic CT shorting mechanism at the time of drawing out the unit makes it very easy to maintain the relay.

Remarks: This mechanism is installed only in relay devices with current protection element.

## 7.2. Standard Ratings

Item		Contents
Rating	Current	5 A
	Zero-sequence current	1 A
	Zero-sequence voltage	100 ~ 208 V
	Frequency	50 Hz / 60 Hz
	Power Supply	Voltage
Variation range		DC: 85 ~ 242 V (Range of 80 ~ 286 V is allowable temporarily.) AC: 85 ~ 242 V (Range of 85 ~ 253 V is allowable temporarily.)
Communication function*	CC-LINK	Option

### 7.3. Protection elements

Protection element	Operating value	Operating time	Other setting
50 (Instantaneous Overcurrent / Instantaneous Overcurrent with selectable 2 <sup>nd</sup> harmonic restraint)	0.5 ~ 100.0 A	0.00 ~ 10.00 s (0.01 s step)  In setting 0.00 s, instantaneous operating time is less than 30 ms. (With 2 <sup>nd</sup> harmonic restraint, operating time is less than 40ms.)	
51 (IDMT Overcurrent)	0.5 ~ 100.0 A	-	14 kinds of operating time characteristics, 3 kinds of recovery time characteristics 3 kinds
67G (Instantaneous Directional Ground Fault / Instantaneous Directional Ground Fault with selectable 2 <sup>nd</sup> harmonic restraint)	CFP1-A42D1 : 2.0 ~ 100.0 V, 1.0 ~ 100.0 mA, 0° ~ 90° (Lead angle)  CFP1-A43D1 : 2.0 ~ 100.0 V, 0.05 ~ 1.00 A, 0° ~ 90° (Lead angle)	0.00 ~ 10.00 s	

\* Factory settings are set to a default of "Non-use" for the items with setting of Use/Non-use. If the Use/Non-use setting is not applicable, the setting value will be set to the minimum setting.

\* For details about protective function, refer to Chapter 8.

## 7.4. Measuring element

- CFP1-A42D1

Contents displayed		Range (Secondary value / Primary value)	Measured value		Accident record	Waveform record
Name of signal	Item		Primary	Secondary	Primary only	Common
VG	Zero-phase voltage	0.0 ~ 247.0 V (0.1 V step) / 0.0 ~ 750.0 kV (0.1 kV step)	○	○	○	○
Ia	A-phase current	0.00 ~ 10.00 A (0.01 A step) / 0 ~ 60000 A (1 A step)	○	○	○	○
Ic	C-phase current		○	○	○	○
IG	Zero-phase current (ZCT)	0.0 ~ 999.9 mA (0.1 mA step) / 0.0 ~ 999.9 A (0.1 A step)	○	○	○	○
VG-phase	Phase angle of VG	0.0 ~ 359.9 ° (0.1 ° step) On the basis of Ia (Lag angle)	○	○	○	×
Ia-phase	Phase angle of Ia		○	○	○	×
Ic-phase	Phase angle of Ic		○	○	○	×
IG-phase	Phase angle of IG		○	○	○	×

- CFP1-A43D1

Contents displayed		Range (Secondary value / Primary value)	Measured value		Accident record	Waveform record
Name of signal	Item		Primary	Secondary	Primary only	Common
VG	Zero-phase voltage	0.0 ~ 247.0 V (0.1 V step) / 0.0 ~ 750.0 kV (0.1 kV step)	○	○	○	○
Ia	A-phase current	0.00 ~ 10.00 A (0.01 A step) / 0 ~ 60000 A (1 A step)	○	○	○	○
Ib	B-phase current		○	○	○	○
Ic	C-phase current		○	○	○	○
IG	Zero-phase current (ZCT)	0.00 ~ 2.00 A (0.01 A step) / 0 ~ 60000 A (1 A step)	○	○	○	○
VG-phase	Phase angle of VG	0.0 ~ 359.9 ° (0.1 ° step) On the basis of Ia (Lag angle)	○	○	○	×
Ia-phase	Phase angle of Ia		○	○	○	×
Ib-phase	Phase angle of Ib		○	○	○	×
Ic-phase	Phase angle of Ic		○	○	○	×
IG-phase	Phase angle of IG		○	○	○	×

## 7.5. List of functions

Menu	Item	Operation system	
		PC-HMI	Front panel
Status (STATUS)	Clock (CLOCK)	○	○
	Measured analog value (METERING)	○	○
	DI/DO status (DIGITAL I/O)	○	○
	Trip counter (TRIP COUNTER)	○	○
	Device name (DEVICE NAME)	○	○
	Monitoring	○	×
	LED reset	○	×
Record (RECORD)	Waveform analysis	○	×
	Disturbance record	○	×
	Fault record (FAULT RECORD)	○ (*)	○
	Event record (EVENT RECORD)	○	○
	Access record (ACCESS RECORD)	○	○
	Alarm record (ALARM RECORD)	○	○
Setting (SETTING)	Active group (ACTIVE WG)	○	○
	Group 1 setting (G1)	○	○
	Group 2 setting (G2)	○	○
	PLC	○	×
Configuration (CONFIG)	Communication setting (COMMUNICATION)	×	○
	Clock adjustment (CLOCK ADJUST)	○	○
	Analog value display switching (METERING)	○	○
	Trip counter (TRIP COUNTER)	○	○
	Disturbance record (DISTURBANCE)	○	○
	Password use/unuse (PASSWORD USE)	×	○
	Password registration (PASSWORD REGIST)	×	○
	Device name setting	○	×
	Time management setting	○	×
	DO contact test setting	○	×
Test (TEST)	DO contact test (CONTACT TEST)	○	○
	Test mode (MODE)	○	○
	LED/VFD lighting test (LED/VFD TEST)	×	○
	Forced operation of relay	○	×
Clear record (RECORD-CLR)	Clear fault record (FAULT REC CLEAR)	○	○
	Clear alarm record (ALARM REC CLEAR)	○	○
	Clear event record (EVENT REC CLEAR)	○	○

(\*) In PC-HMI, the item of Fault record is included in Disturbance analysis.

## 8. Protective function

In the relay, following protection elements are provided for the purposes of feeder protection. In this chapter, the protection elements incorporated in the relay are described.

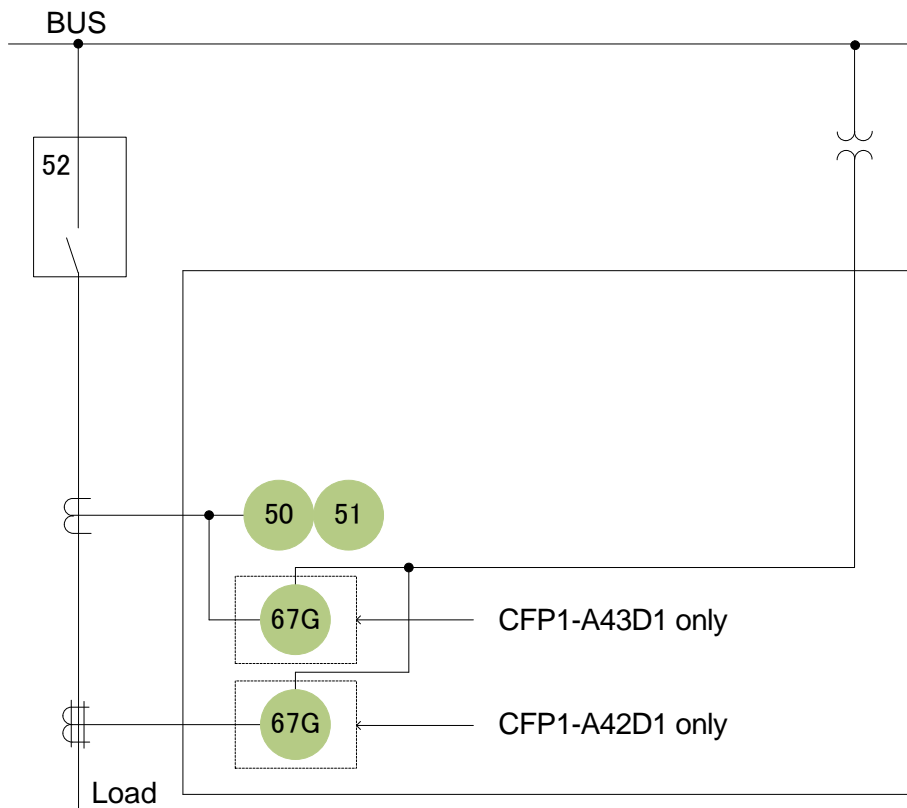

Model	Protection elements	Input	Purpose
CFP1-A42D1	50, 51, 67G	Ia, Ic (2 phase) I0 : JEC1201 standardized goods V0 : EVT	For high-resistance grounding system I0 from ZCT and V0 from EVT detects 67G.
CFP1-A43D1	50, 51, 67G	Ia, Ib, Ic (3 phase) I0 : 3CT residual circuit V0 : EVT	For resistance grounding system. I0 from 3CT residual circuit and V0 from EVT detects 67G.

## 8.1. Overcurrent element

Four types of overcurrent elements are incorporated in CFP1-A42D1 and CFP1-A43D1 relay, and this enables rapid detection of faults. Furthermore, a variety of protection characteristics are provided which enable effective time coordination as shown in Fig. 8-1. Accordingly, the relay can be applied to protect various systems. Furthermore, second harmonic restraint is incorporated, and this can prevent unnecessary operation due to transformer magnetizing inrush current.

Apparatus No.	Display name	Protective function
50	OC1	Instantaneous overcurrent element
	OC2, OC3	Instantaneous overcurrent element (two-stage) with selectable 2 <sup>nd</sup> harmonic restraint
51	OC4	Definite time or IDMT overcurrent element with selectable 2 <sup>nd</sup> harmonic restraint; <ul style="list-style-type: none"> <li>● Selection of 14 operating time characteristics</li> <li>● 3 reset time characteristics</li> </ul>

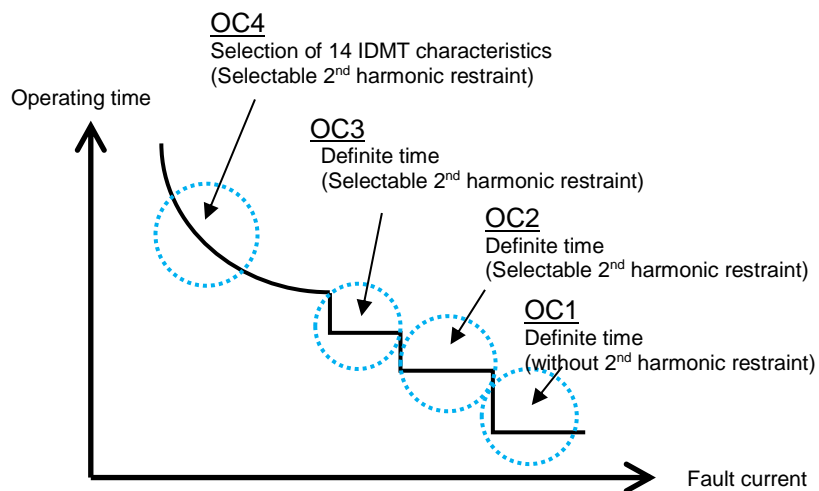

**Fig. 8-1 Example of a time coordination curve for overcurrent element**

### 8.1.1. OC1 element (Instantaneous Overcurrent element)

As the instantaneous overcurrent element operates without 2<sup>nd</sup> harmonic restraint, it is possible to achieve high-speed operation for large fault currents. Fig. 8-2 shows the internal function blocks of the element.

OC1 outputs a definitive signal after a preset time of the operation timer (Ope. Time) has passed, when input current is greater than or equal to the operation setting value (Ope. Curt.).

An off-delay timer of 200 ms is added in order to prevent chattering of the output contacts.

Furthermore, this element is enabled only when the setting of Use/Non-use of OC1 (OC1 EN) is set to ON. Therefore, when this element is not used, unnecessary operation can be prevented by setting to OFF. It is not necessary to set other setting items with regard to OC1 element.

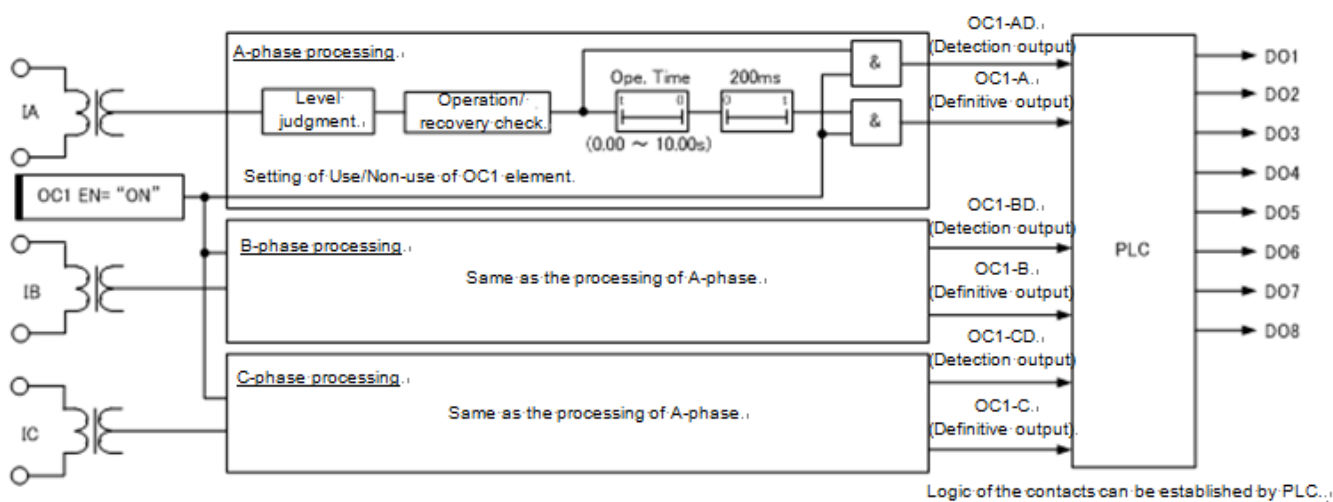

**Fig. 8-2 Internal function block diagram of the instantaneous overcurrent element (OC1)**

**Table 8-1 Setting items of the instantaneous overcurrent element (OC1)**

Display name	Setting parameter	Setting		Description
		Range of setting	step	
OC1	OC1 EN	OFF, ON	-	OFF: Non-use, ON: Use When this element is used, set to ON.
	Ope. Curt.	0.5 ~ 100.0 A	0.1 A	Operating current
	Ope. Time	0.00 ~ 10.00 s	0.01 s	Operating time INST: ≤ 30 ms

8.1.2. OC2 element (Instantaneous overcurrent element with 2<sup>nd</sup> harmonic restraint)

This element includes the selectable 2<sup>nd</sup> harmonic restraint function so it can prevent unnecessary operation due to transformer magnetizing inrush current.

Fig. 8-3 shows the internal function blocks of the element.

The OC2 element outputs a definitive signal after the preset time of the operation timer (Ope. Time) has passed, when the input current is greater than or equal to the operation setting value (Ope. Curt.), and when 2<sup>nd</sup> harmonic restraint is not operated.

When the 2<sup>nd</sup> harmonic restraint function is not used (2f-lock EN=OFF), it is not linked to the operation of the OC2 element.

An off-delay timer of 200 ms is added in order to prevent chattering of the output contacts.

Furthermore, this element outputs the trip signal only when the setting of Use/Non-use of OC2 element (OC2 EN) is ON. Therefore, when this element is not used, unnecessary operation can be prevented by setting to OFF. It is not necessary to set other setting items with regard to OC2 element.

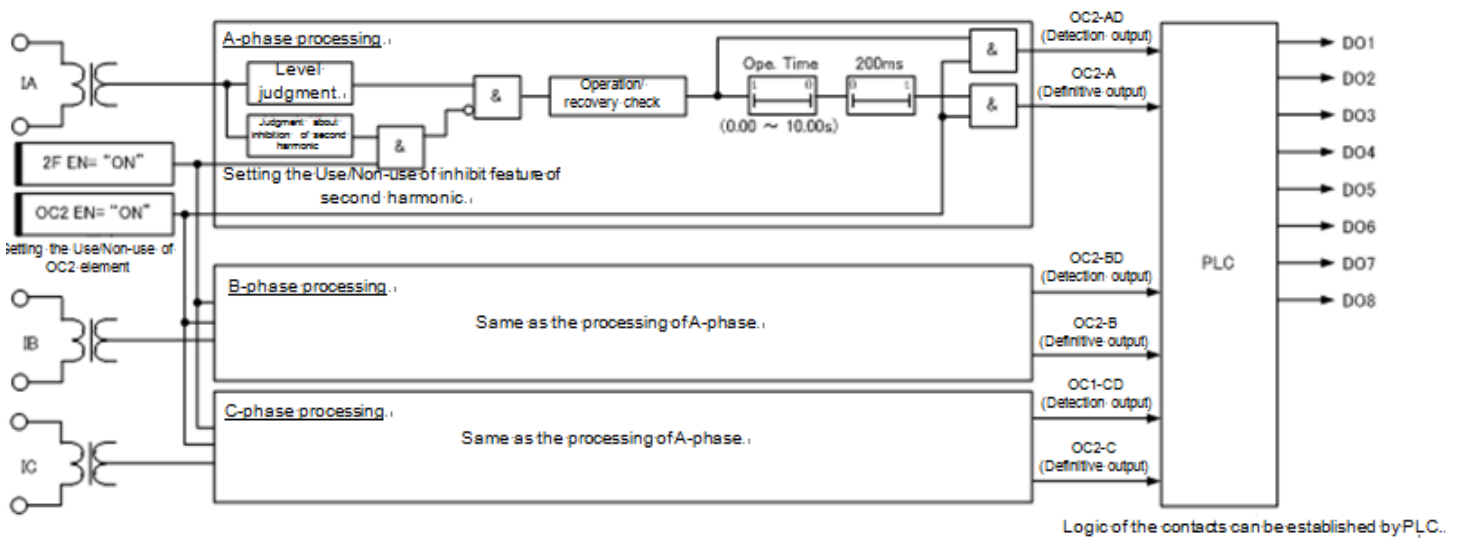

Fig. 8-3 Internal function block diagram of OC2 element

Table 8-2 Setting items of OC2 element

Display name	Setting parameter	Setting		Description
		Range of setting	step	
OC2	OC2 EN	OFF, ON	-	OFF: Non-use, ON: Use When this element is used, set to ON.
	Ope. Curt.	0.5 ~ 100.0 A	0.1 A	Operating current
	Ope. Time	0.00 ~ 10.00 s	0.01 s	Operating time INST: ≤ 40 ms (2f-lock EN=ON)
	2f-lock EN	OFF, ON	-	OFF: Non-use, ON: Use When the 2 <sup>nd</sup> harmonic restraint function is used, set to ON.

### 8.1.2.1. 2<sup>nd</sup> harmonic restraint function

In the relay, 2<sup>nd</sup> harmonic restraint function is provided in order to prevent unnecessary operation due to transformer magnetizing inrush current. The operation of 2<sup>nd</sup> harmonic restraint function is explained by means of the internal function blocks shown in Fig. 8-4.

As there is significant second harmonic component in the transformer magnetizing inrush current, the relay extracts the fundamental and second harmonic components in the input current. It detects the second harmonic when the fundamental component is greater than or equal to the minimum operation setting value (1f-Min. Ope.), and when the 2nd harmonic component is greater than or equal to the setting of content percentage (2f-lock ratio) of fundamental component. Furthermore, in order to reduce chattering of output contacts when the 2f component is near the setting of content percentage, the detection signal is latched when the 2f component is continuously detected during one cycle (\*1). (Release of the latch is done after 1.5 cycles when the 2f component has become less than the percentage setting of fundamental component.)

(\*1) 1 cycle is calculated by the following formula.

1 cycle (sec) = 1/System frequency----- (16.7 ms @60 Hz, 20 ms @50 Hz)

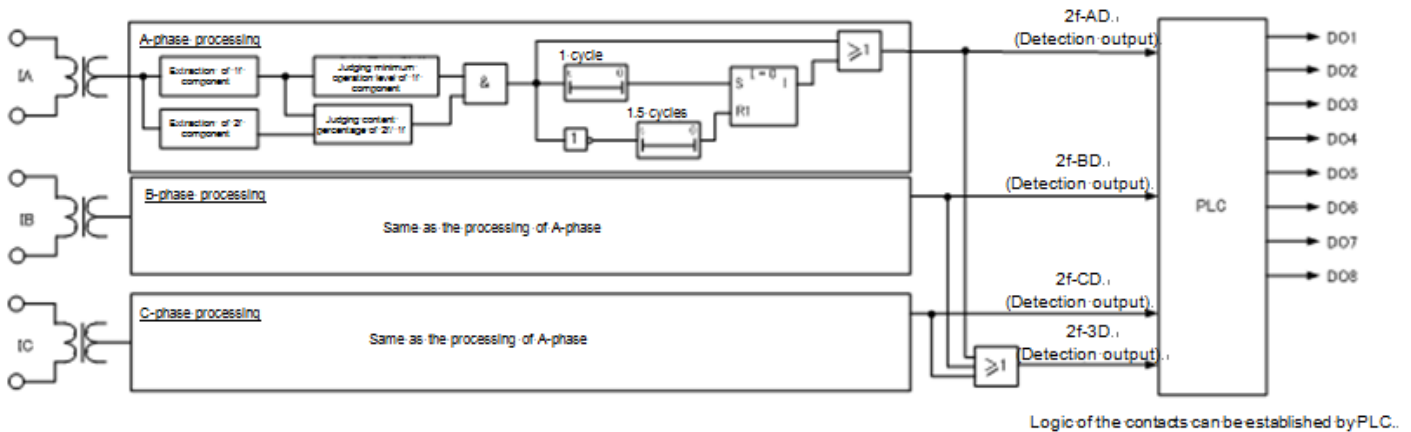

**Fig. 8-4 Internal block diagram for 2<sup>nd</sup> harmonic restraint**

**Table 8-3 Setting items of 2<sup>nd</sup> harmonic restraint function**

Display name	Setting parameter	Setting		Description
		Range of setting	step	
2F	2f-lock ratio	10 ~ 30%	1%	Content percentage of 2f/1f
	1f-Min. Ope.	0.4 ~ 2.5 A	0.1 A	Minimum operating value of 1f component

### 8.1.3. OC3 element (Instantaneous overcurrent element with 2nd harmonic restraint)

The OC3 element has the same characteristics as the OC2 element.

Regarding the internal function block diagram and its operation, refer to sub-clause 8.1.2.

**Table 8-4 Setting items of OC3 element**

Display name	Setting parameter	Setting		Description
		Range of setting	step	
OC3	OC3 EN	OFF, ON	-	OFF: Non-use, ON: Use When this element is used, set to ON.
	Ope. Curt.	0.5 ~ 100.0 A	0.1 A	Operating current
	Ope. Time	0.00 ~ 10.00 s	0.01 s	Operating time INST: ≤ 40 ms (2F EN=ON)
	2f-lock EN	OFF, ON	-	OFF: Non-use, ON: Use When the second harmonic restraint function is used, set to ON.

8.1.4. OC4 element (Definite time or IDMT overcurrent with 2<sup>nd</sup> harmonic restraint)

As selectable second harmonic restraint function is incorporated, unnecessary operation due to transformer magnetizing inrush current can be avoided. Furthermore, 14 kinds of operating time characteristics and 3 types of reset time characteristics are provided.

Fig. 8-5 shows the internal function blocks of the element.

The OC4 element outputs a definitive signal when detection signal operates for longer than a definite time setting.

The detection signal is issued when input current is greater than or equal to the operation setting value (Ope. Curt. or Ope. Curt.x1.15 is to be selected by setting of IEC Chr. EN), and when 2<sup>nd</sup> harmonic restraint is not operated.

The DT or IDMT timer counts up in accordance with the operating time characteristic (Ope. Chr.), when input current is greater than or equal to the operation setting value (Ope. Curt.), and when 2<sup>nd</sup> harmonic restraint is not operated.

When the 2<sup>nd</sup> harmonic restraint function is not used (2f-lock EN=OFF), it is not linked to the operation of the OC4 element.

The reset time characteristic can be selected by setting (Rst. Chr.).

When set to IDMT (inverse definite minimum time) or DT (definite time), it is included an off-delay timer of 200 ms to prevent chattering of the contacts.

When instantaneous reset of the contact is required, the setting (Rst. Chr.) should be set to INST (instantaneous).

Furthermore, this element outputs the definitive signal only when the setting of Use/Non-use of OC4 element (OC4 EN) is ON. Therefore, when this element is not used, unnecessary operation can be prevented by setting to OFF. It is not necessary to set any other settings with regard to the OC4 element.

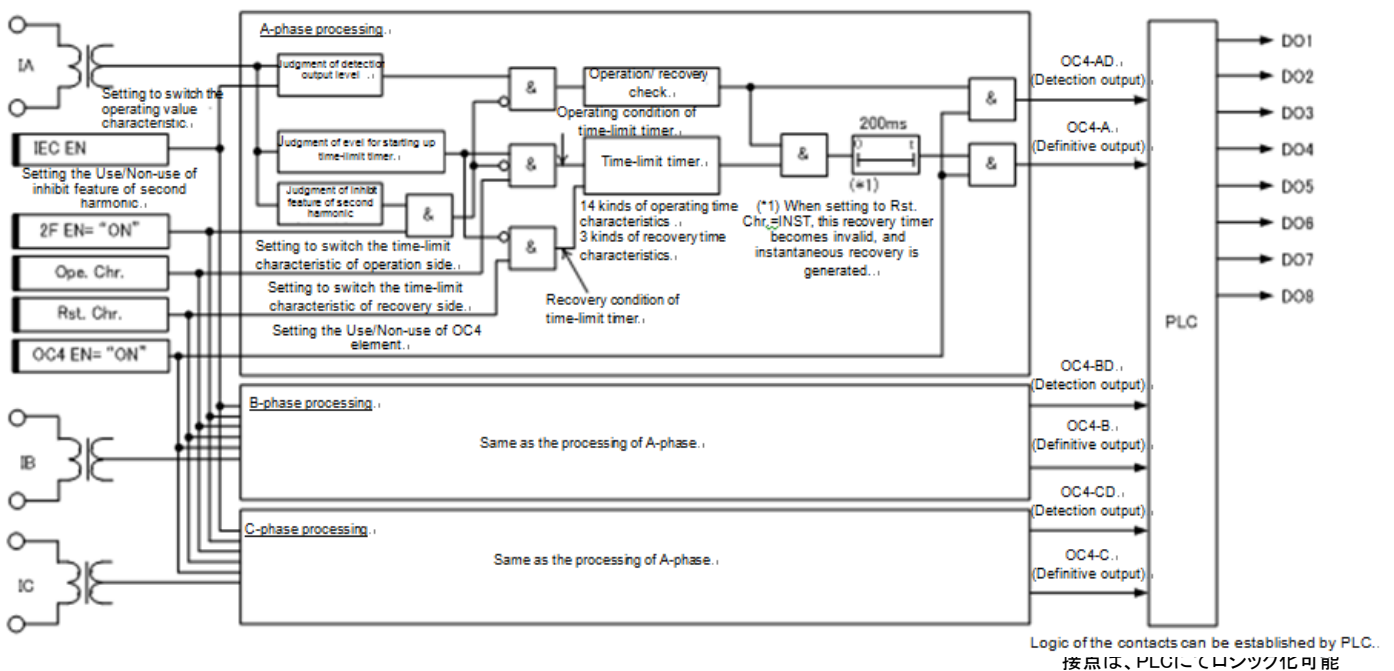

Fig. 8-5 Internal function block diagram of OC4 element

**Table 8-5 Setting items of OC4 element**

Display name	Setting parameter	Setting		Description
		Range of setting	step	
OC4	OC4 EN	OFF, ON	-	OFF: Non-use, ON: Use When this element is used, set to ON.
	Ope. Curt.	0.5 ~ 100.0 A	0.1 A	Operating current (pickup current)
	Ope. TM	0.25 ~ 50.00	0.01	Operating time multiplier. This is indicated as "M" in the characteristic formula shown in sub-clause 8.1.4.3.
	Ope. Chr.	NI01, VI01, EI01, LI01, LI02, DT01, NI11, EI11, EI12, NI21, VI21, LI21, NI31, VI31	-	Choice of DT or IDMT operating characteristics. (Refer to IDMT characteristic formula in sub-clause 8.1.4.3.)
	Rst. Chr.	IDMT,DT,INST	-	Reset time characteristic. IDMT: Inverse definite minimum time. DT: Definite time (fixed to 200 ms) INST: Instantaneous (50 ms or less) (Refer to IDMT characteristic formula in sub-clause 8.1.4.3.)
	2f-lock EN	OFF, ON	-	OFF: Non-use, ON: Use When 2 <sup>nd</sup> harmonic restraint is used, set to ON.
	IEC Chr. EN	OFF, ON	-	OFF: Normal characteristic, ON: Characteristic according to IEC When this element is used with the operating characteristic compliant with IEC60255-151, set this parameter to ON. By setting this parameter to ON, the operating value for detection becomes 1.15 times the Ope. Curt., as shown in sub-clause 8.1.4.1.

8.1.4.1. Operating time characteristic

The characteristic based on IEC60255-151 is incorporated in the OC4 element, and it is possible to select the operation by setting of IEC Chr. EN. The difference is described in Fig. 8-6.

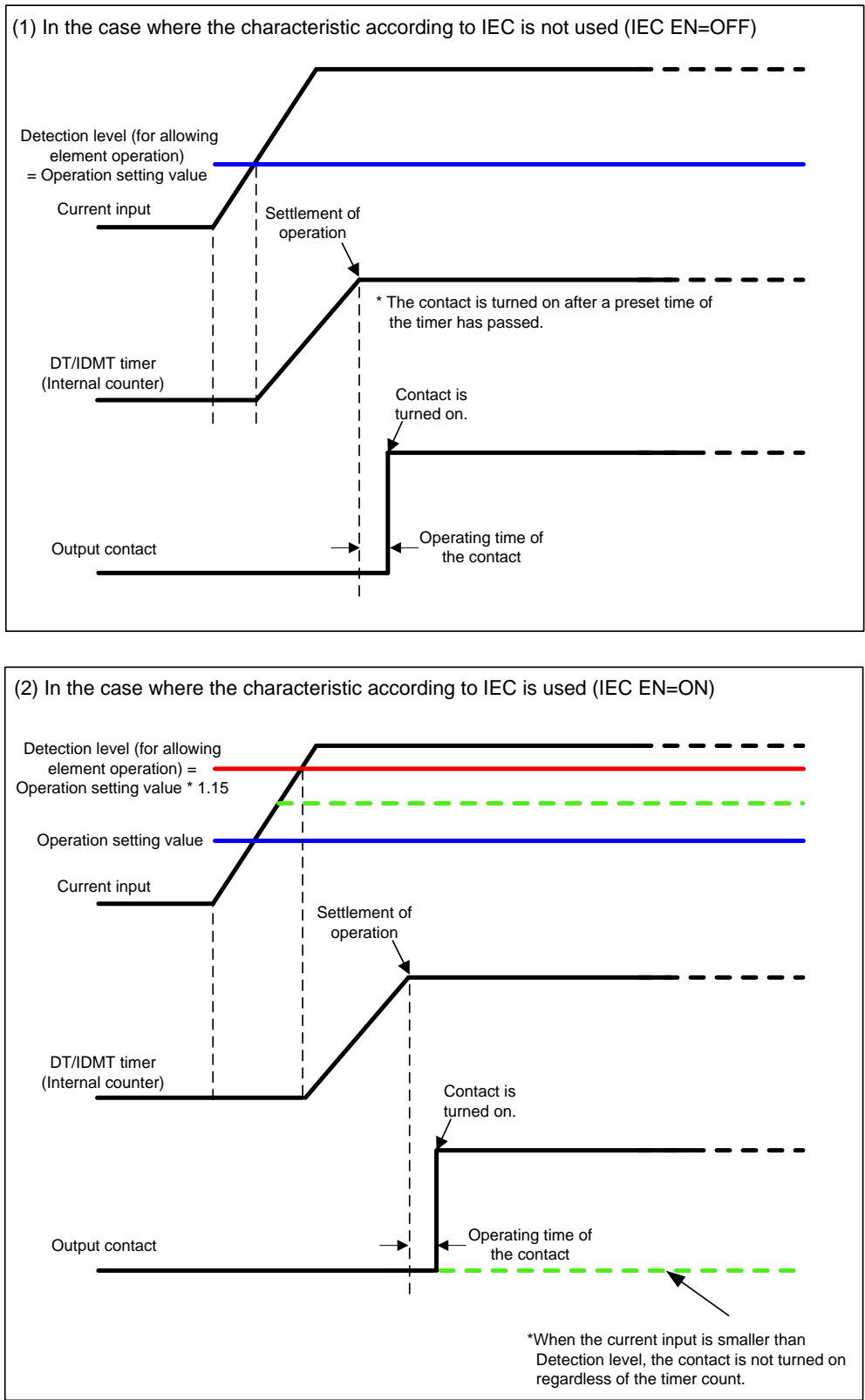

Fig. 8-6 Comparison of the operation between IEC EN=ON and IEC EN=OFF

### 8.1.4.2. Reset time characteristic

There are 3 types of resetting time characteristics associated with the OC4 element which can be selected.

- Instantaneous reset
- Definite time reset
- IDMT (Inverse definite minimum time) reset

These resetting characteristics are illustrated in Fig. 8-7 and Fig. 8-8.

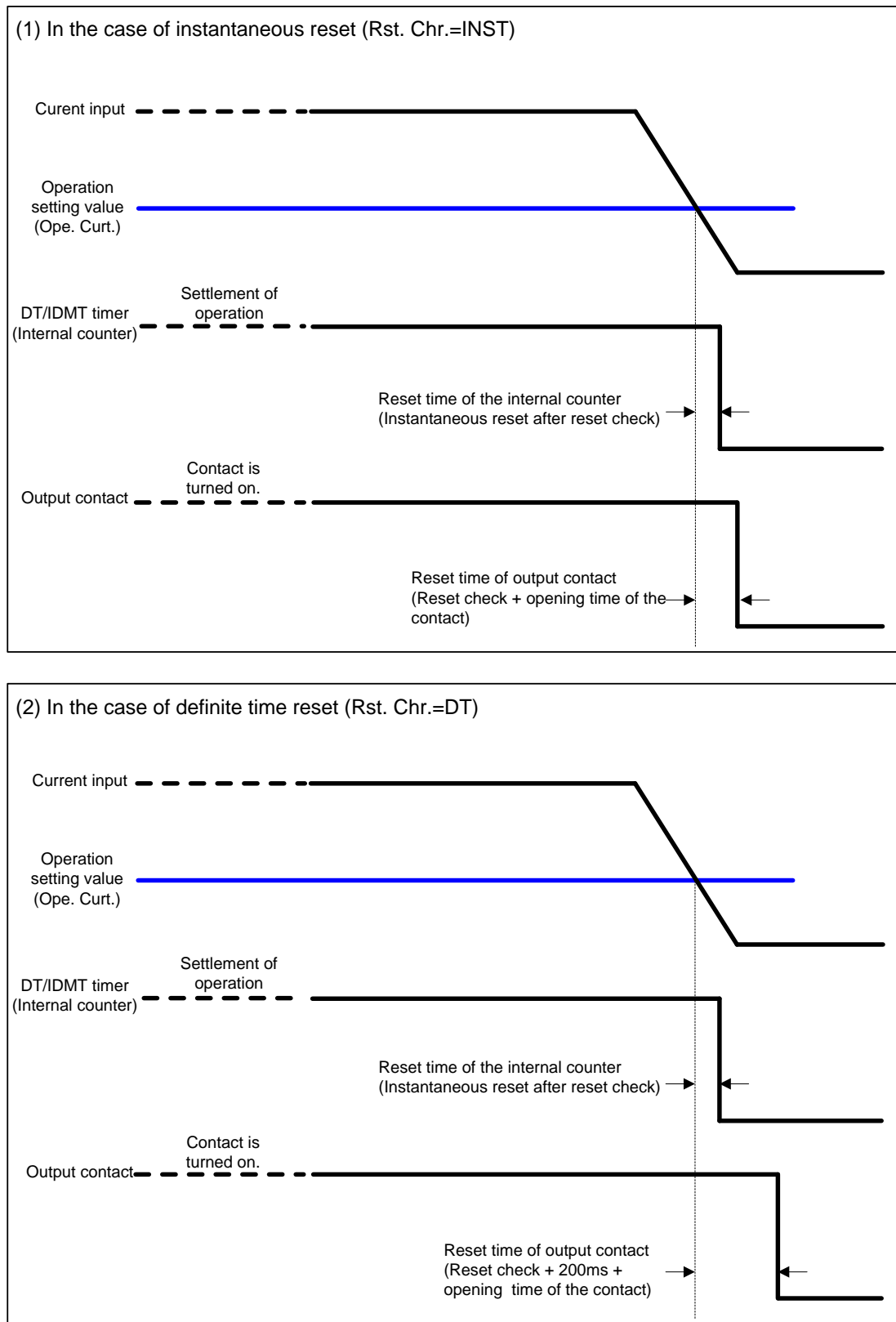
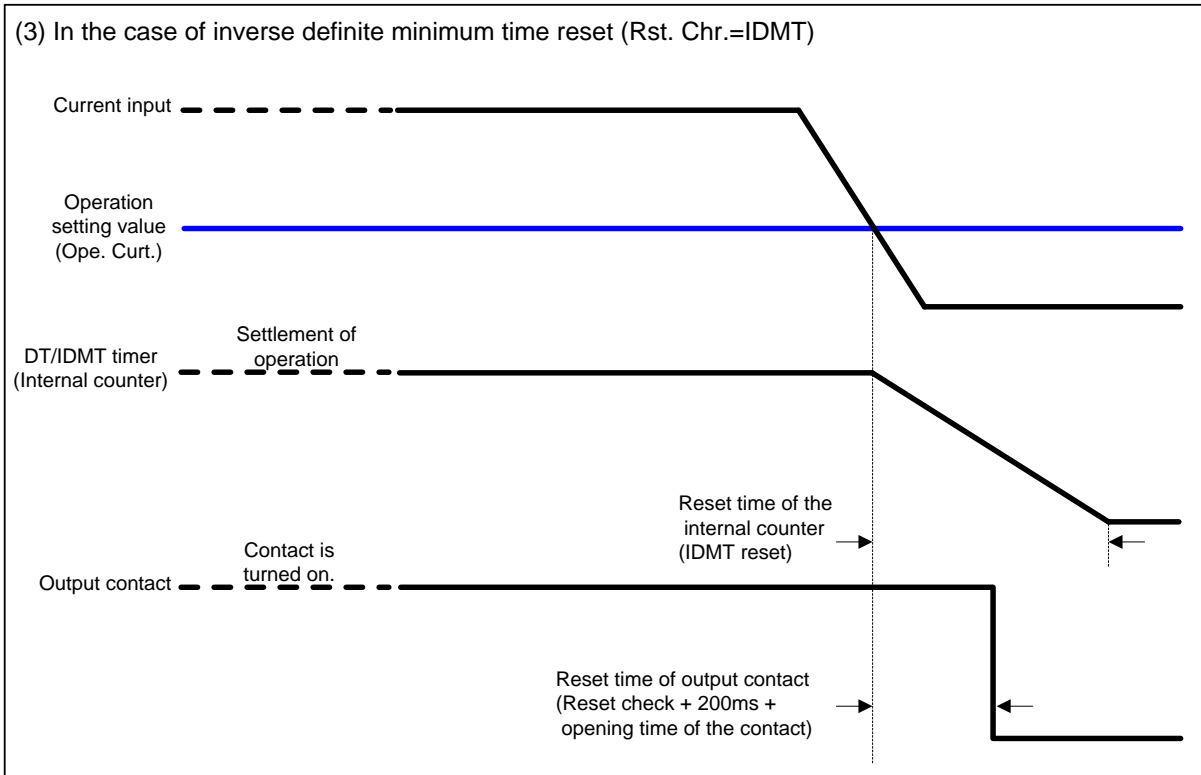

Fig. 8-7 Reset time characteristic (1)



**Fig. 8-8 Reset time characteristic (2)**

For details in regard to Fig. 8-8, refer to sub-clause 8.1.4.3.

8.1.4.3. IDMT characteristic

14 types of operating time characteristics and 3 types of reset time characteristics are provided in the OC4 element.

Operation time

$$t = \left\{ \left[ \frac{k}{I^\alpha - 1} \right] + C \right\} \times \frac{M}{10}$$

Reset time

$$t = \left[ \frac{8}{1 - I^2} \right] \times \frac{M}{10}$$

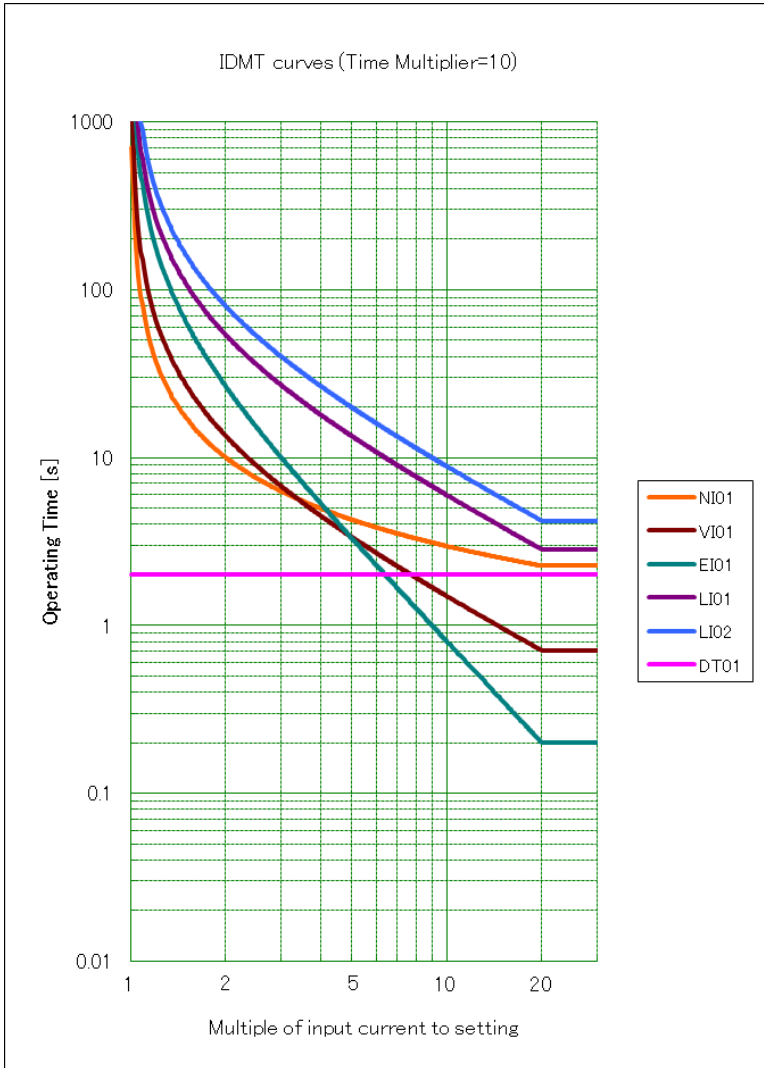

[1] IEC Normal Inverse (NI01)

$$t = \frac{0.14}{I^{0.02} - 1} \times \frac{M}{10} (s)$$

[2] IEC Very Inverse (VI01)

$$t = \frac{13.5}{I - 1} \times \frac{M}{10} (s)$$

[3] IEC Extremely Inverse (EI01)

$$t = \frac{80}{I^2 - 1} \times \frac{M}{10} (s)$$

[4] Long Time Inverse (LI01)

$$t = \frac{54}{I - 1} \times \frac{M}{10} (s)$$

[5] Long Time Inverse (LI02)

$$t = \frac{80}{I} \times \frac{M}{10} (s)$$

[6] Definite time characteristic (DT01)

$$t = 2 \times \frac{M}{10} (s)$$

*t*: Operating time (s)

*I*: Multiple of input current value to the setting value (times)

*M*: Operating time multiplier (times)

Fig. 8-9 Operating time characteristic (1)

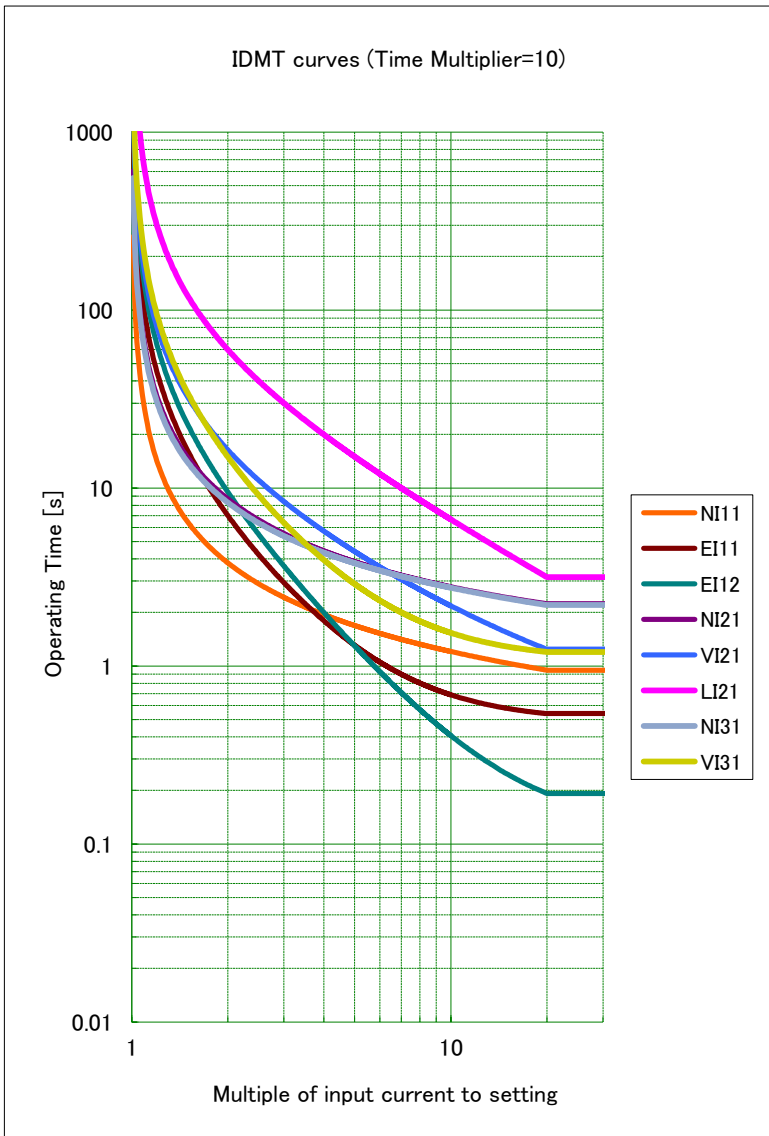

[7] IEEE Moderately Inverse (NI11)

$$t = \left( \frac{0.0515}{I^{0.02} - 1} + 0.114 \right) \times \frac{M}{10} (s)$$

[8] IEEE Very Inverse (EI11)

$$t = \left( \frac{19.61}{I^2 - 1} + 0.491 \right) \times \frac{M}{10} (s)$$

[9] IEEE Extremely Inverse (EI12)

$$t = \left( \frac{28.2}{I^2 - 1} + 0.1217 \right) \times \frac{M}{10} (s)$$

[10] Normal Inverse (NI21)

$$t = \left( \frac{2.4}{I^{0.4} - 1} + 1.2 \right) \times \frac{M}{10} (s)$$

[11] Very Inverse (VI21)

$$t = \left( \frac{16}{I - 1} + 0.4 \right) \times \frac{M}{10} (s)$$

[12] Long Time Inverse (LI21)

$$t = \frac{60}{I - 1} \times \frac{M}{10} (s)$$

[13] Korean Normal Inverse (NI31)

$$t = \left( \frac{0.11}{I^{0.02} - 1} + 0.42 \right) \times \frac{M}{10} (s)$$

[14] Korean Very Inverse (VI31)

$$t = \left( \frac{39.85}{I^{1.95} - 1} + 1.084 \right) \times \frac{M}{10} (s)$$

*t*: Operating time (s)

*I*: Multiple of input current value to the setting value (times)

*M*: Operating time multiplier (times)

Fig. 8-10 Operating time characteristic (2)

Fig. 8-11 shows the dependent resetting time characteristic of the internal counter when the setting of OC4-Rst.Chr. = IDMT is selected.

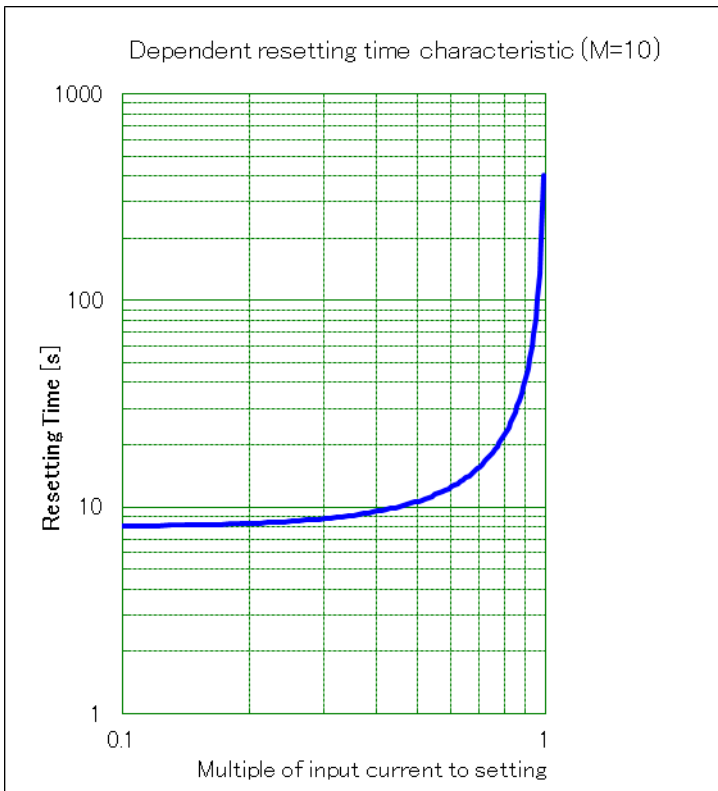

$$t_r = \frac{8}{1 - I^2} \times \frac{M}{10} (s)$$

$t_r$ : Reset time (s)

$I$ : Multiple of input current value to the setting value (times)

$M$ : Reset time multiplier (times)

**Fig. 8-11 Dependent reset time characteristic**

**\*Note for the IDMT reset characteristic**

Although the output contact resets at the definite time (0.2 s) after the input current is smaller than the operation setting value, the internal operation counter will be decreased by the IDMT characteristic which is similar to the reset characteristic of an induction disk type electromechanical overcurrent relay. This reset characteristic may be useful for intermittent overload detection at motor start-up and etc. For details, refer to sub-clause 8.1.4.2.

**Table 8-6 IEC Normal inverse (NI01) Operating time accuracy table**

Unit: s

Operating time multiplier setting (M)	Multiple of input relative to operating time		
	300%	500%	1000%
0.25	0.158 ± 5.50%	0.107 ± 3.75%	0.074 ± 3.75%
	* 0.050 ~ 0.504	* 0.050 ~ 0.267	* 0.050 ~ 0.186
0.5	0.315 ± 5.67%	0.214 ± 3.83%	0.149 ± 3.83%
	* 0.050 ~ 0.672	* 0.050 ~ 0.378	* 0.050 ~ 0.262
1	0.630 ± 6.00%	0.428 ± 4.00%	0.297 ± 4.00%
	0.252 ~ 1.008	0.257 ~ 0.599	0.178 ~ 0.416
1.5	0.945 ± 6.33%	0.642 ± 4.17%	0.446 ± 4.17%
	0.546 ~ 1.344	0.464 ~ 0.820	0.322 ~ 0.569
2	1.260 ± 6.67%	0.856 ± 4.33%	0.594 ± 4.33%
	0.840 ~ 1.681	0.670 ~ 1.041	0.465 ~ 0.723
2.5	1.575 ± 7.00%	1.070 ± 4.50%	0.743 ± 4.50%
	1.134 ~ 2.017	0.877 ~ 1.263	0.609 ~ 0.876
3	1.891 ± 7.33%	1.284 ± 4.67%	0.891 ± 4.67%
	1.428 ~ 2.353	1.084 ~ 1.484	0.753 ~ 1.030
3.5	2.206 ± 7.67%	1.498 ± 4.83%	1.040 ± 4.83%
	1.723 ~ 2.689	1.291 ~ 1.705	0.896 ~ 1.183
4	2.521 ± 8.00%	1.712 ± 5.00%	1.188 ± 5.00%
	2.017 ~ 3.025	1.498 ~ 1.926	1.040 ~ 1.337
4.5	2.836 ± 8.33%	1.926 ± 5.17%	1.337 ± 5.17%
	2.311 ~ 3.361	1.705 ~ 2.147	1.183 ~ 1.490
5	3.151 ± 8.67%	2.140 ± 5.33%	1.485 ± 5.33%
	2.605 ~ 3.697	1.912 ~ 2.368	1.327 ~ 1.644
6	3.781 ± 9.33%	2.568 ± 5.67%	1.782 ± 5.67%
	3.193 ~ 4.369	2.325 ~ 2.810	1.614 ~ 1.951
7	4.411 ± 10.00%	2.996 ± 6.00%	2.079 ± 6.00%
	3.781 ~ 5.042	2.739 ~ 3.253	1.901 ~ 2.258
8	5.042 ± 10.67%	3.424 ± 6.33%	2.376 ± 6.33%
	4.369 ~ 5.714	3.153 ~ 3.695	2.188 ~ 2.565
9	5.672 ± 11.33%	3.852 ± 6.67%	2.674 ± 6.67%
	4.958 ~ 6.386	3.566 ~ 4.137	2.475 ~ 2.872
10	6.302 ± 12.00%	4.280 ± 7.00%	2.971 ± 7.00%
	5.546 ~ 7.058	3.980 ~ 4.579	2.763 ~ 3.179
15	9.453 ± 12.00%	6.420 ± 7.00%	4.456 ± 7.00%
	8.319 ~ 10.587	5.970 ~ 6.869	4.144 ~ 4.768
20	12.604 ± 12.00%	8.559 ± 7.00%	5.941 ± 7.00%
	11.091 ~ 14.116	7.960 ~ 9.159	5.525 ~ 6.357
30	18.906 ± 12.00%	12.839 ± 7.00%	8.912 ± 7.00%
	16.637 ~ 21.174	11.940 ~ 13.738	8.288 ~ 9.536
40	25.208 ± 12.00%	17.119 ± 7.00%	11.882 ± 7.00%
	22.183 ~ 28.233	15.921 ~ 18.317	11.051 ~ 12.714
50	31.510 ± 12.00%	21.399 ± 7.00%	14.853 ± 7.00%
	27.728 ~ 35.291	19.901 ~ 22.897	13.813 ~ 15.893

**Table 8-7 IEC Very inverse (VI01) Operating time accuracy table**

Unit: s

Operating time multiplier setting (M)	Multiple of input relative to operating time		
	300%	500%	1000%
0.25	0.169 ± 5.50%	0.084 ± 3.75%	0.038 ± 3.75%
	* 0.050 ~ 0.540	* 0.050 ~ 0.211	* 0.050 ~ 0.094
0.5	0.338 ± 5.67%	0.169 ± 3.83%	0.075 ± 3.83%
	* 0.050 ~ 0.720	* 0.050 ~ 0.298	* 0.050 ~ 0.133
1	0.675 ± 6.00%	0.338 ± 4.00%	0.150 ± 4.00%
	0.270 ~ 1.080	0.203 ~ 0.473	0.090 ~ 0.210
1.5	1.013 ± 6.33%	0.506 ± 4.17%	0.225 ± 4.17%
	0.585 ~ 1.440	0.366 ~ 0.647	0.163 ~ 0.288
2	1.350 ± 6.67%	0.675 ± 4.33%	0.300 ± 4.33%
	0.900 ~ 1.800	0.529 ~ 0.821	0.235 ~ 0.365
2.5	1.688 ± 7.00%	0.844 ± 4.50%	0.375 ± 4.50%
	1.215 ~ 2.160	0.692 ~ 0.996	0.308 ~ 0.443
3	2.025 ± 7.33%	1.013 ± 4.67%	0.450 ± 4.67%
	1.530 ~ 2.520	0.855 ~ 1.170	0.380 ~ 0.520
3.5	2.363 ± 7.67%	1.181 ± 4.83%	0.525 ± 4.83%
	1.845 ~ 2.880	1.018 ~ 1.344	0.453 ~ 0.598
4	2.700 ± 8.00%	1.350 ± 5.00%	0.600 ± 5.00%
	2.160 ~ 3.240	1.181 ~ 1.519	0.525 ~ 0.675
4.5	3.038 ± 8.33%	1.519 ± 5.17%	0.675 ± 5.17%
	2.475 ~ 3.600	1.344 ~ 1.693	0.598 ~ 0.753
5	3.375 ± 8.67%	1.688 ± 5.33%	0.750 ± 5.33%
	2.790 ~ 3.960	1.508 ~ 1.868	0.670 ~ 0.830
6	4.050 ± 9.33%	2.025 ± 5.67%	0.900 ± 5.67%
	3.420 ~ 4.680	1.834 ~ 2.216	0.815 ~ 0.985
7	4.725 ± 10.00%	2.363 ± 6.00%	1.050 ± 6.00%
	4.050 ~ 5.400	2.160 ~ 2.565	0.960 ~ 1.140
8	5.400 ± 10.67%	2.700 ± 6.33%	1.200 ± 6.33%
	4.680 ~ 6.120	2.486 ~ 2.914	1.105 ~ 1.295
9	6.075 ± 11.33	3.038 ± 6.67%	1.350 ± 6.67%
	5.310 ~ 6.840	2.813 ~ 3.263	1.250 ~ 1.450
10	6.750 ± 12.00%	3.375 ± 7.00%	1.500 ± 7.00%
	5.940 ~ 7.560	3.139 ~ 3.611	1.395 ~ 1.605
15	10.125 ± 12.00%	5.063 ± 7.00%	2.250 ± 7.00%
	8.910 ~ 11.340	4.708 ~ 5.417	2.093 ~ 2.408
20	13.500 ± 12.00%	6.750 ± 7.00%	3.000 ± 7.00%
	11.880 ~ 15.120	6.278 ~ 7.223	2.790 ~ 6.357
30	20.250 ± 12.00%	10.125 ± 7.00%	4.500 ± 7.00%
	17.820 ~ 22.680	9.416 ~ 10.834	4.185 ~ 4.815
40	27.000 ± 12.00%	13.500 ± 7.00%	6.000 ± 7.00%
	23.760 ~ 30.240	12.555 ~ 14.445	5.580 ~ 6.420
50	33.750 ± 12.00%	16.875 ± 7.00%	7.500 ± 7.00%
	29.700 ~ 37.800	15.694 ~ 18.056	6.975 ~ 8.025

**Table 8-8 IEC Extremely inverse (EI01) Operating time accuracy table**

Unit: s

Operating time multiplier setting (M)	Multiple of input relative to operating time		
	300%	500%	1000%
0.25	0.250 ± 5.50%	0.083 ± 3.75%	0.020 ± 0.05
	* 0.050 ~ 0.800	* 0.050 ~ 0.208	* 0.050 ~ 0.070
0.5	0.500 ± 5.67%	0.167 ± 3.83%	0.040 ± 0.05
	* 0.050 ~ 1.067	* 0.050 ~ 0.294	* 0.050 ~ 0.090
1	1.000 ± 6.00%	0.333 ± 4.00%	0.081 ± 0.05
	0.400 ~ 1.600	0.200 ~ 0.467	* 0.050 ~ 0.131
1.5	1.500 ± 6.33%	0.500 ± 4.17%	0.121 ± 0.05
	0.867 ~ 2.133	0.361 ~ 0.639	0.071 ~ 0.171
2	2.000 ± 6.67%	0.667 ± 4.33%	0.162 ± 0.05
	1.333 ~ 2.667	0.522 ~ 0.811	0.112 ~ 0.212
2.5	2.500 ± 7.00%	0.833 ± 4.50%	0.202 ± 0.05
	1.800 ~ 3.200	0.683 ~ 0.983	0.152 ~ 0.252
3	3.000 ± 7.33%	1.000 ± 4.67%	0.242 ± 0.05
	2.267 ~ 3.733	0.844 ~ 1.156	0.192 ~ 0.292
3.5	3.500 ± 7.67%	1.167 ± 4.83%	0.283 ± 0.05
	2.733 ~ 4.267	1.006 ~ 1.328	0.233 ~ 0.333
4	4.000 ± 8.00%	1.333 ± 5.00%	0.323 ± 0.05
	3.200 ~ 4.800	1.167 ~ 1.500	0.273 ~ 0.373
4.5	4.500 ± 8.33%	1.500 ± 5.17%	0.364 ± 0.05
	3.667 ~ 5.333	1.328 ~ 1.672	0.314 ~ 0.414
5	5.000 ± 8.67%	1.667 ± 5.33%	0.404 ± 0.05
	4.133 ~ 5.867	1.489 ~ 1.844	0.354 ~ 0.454
6	6.000 ± 9.33%	2.000 ± 5.67%	0.485 ± 0.05
	5.067 ~ 6.933	1.811 ~ 2.189	0.435 ~ 0.535
7	7.000 ± 10.00%	2.333 ± 6.00%	0.566 ± 0.05
	6.000 ~ 8.000	2.133 ~ 2.533	0.516 ~ 0.616
8	8.000 ± 10.67%	2.667 ± 6.33%	0.646 ± 6.33%
	6.933 ~ 9.067	2.456 ~ 2.878	0.595 ~ 0.698
9	9.000 ± 11.33%	3.000 ± 6.67%	0.727 ± 6.67%
	7.867 ~ 10.133	2.778 ~ 3.222	0.673 ~ 0.781
10	10.000 ± 12.00%	3.333 ± 7.00%	0.808 ± 7.00%
	8.800 ~ 11.200	3.100 ~ 3.567	0.752 ~ 0.865
15	15.000 ± 12.00%	5.000 ± 7.00%	1.212 ± 7.00%
	13.200 ~ 16.800	4.650 ~ 5.350	1.127 ~ 1.297
20	20.000 ± 12.00%	6.667 ± 7.00%	1.616 ± 7.00%
	17.600 ~ 22.400	6.200 ~ 7.133	1.503 ~ 1.729
30	30.000 ± 12.00%	10.000 ± 7.00%	2.424 ± 7.00%
	26.400 ~ 33.600	9.300 ~ 10.700	2.255 ~ 2.594
40	40.000 ± 12.00%	13.333 ± 7.00%	3.232 ± 7.00%
	35.200 ~ 44.800	12.400 ~ 14.267	3.006 ~ 3.459
50	50.000 ± 12.00%	16.667 ± 7.00%	4.040 ± 7.00%
	44.000 ~ 56.000	15.500 ~ 17.833	3.758 ~ 4.323

**Table 8-9 Long inverse (LI01) Operating time accuracy table**

Unit: s

Operating time multiplier setting (M)	Multiple of input relative to operating time		
	300%	500%	1000%
0.25	0.675 ± 5.50%	0.338 ± 3.75%	0.150 ± 3.75%
	* 0.050 ~ 2.160	* 0.050 ~ 0.844	* 0.050 ~ 0.375
0.5	1.350 ± 5.67%	0.675 ± 3.83%	0.300 ± 3.83%
	* 0.050 ~ 2.880	0.158 ~ 1.193	0.070 ~ 0.530
1	2.700 ± 6.00%	1.350 ± 4.00%	0.600 ± 4.00%
	1.080 ~ 4.320	0.158 ~ 1.890	0.360 ~ 0.840
1.5	4.050 ± 6.33%	2.025 ± 4.17%	0.900 ± 4.17%
	2.340 ~ 5.760	1.463 ~ 2.588	0.650 ~ 1.150
2	5.400 ± 6.67%	2.700 ± 4.33%	1.200 ± 4.33%
	3.600 ~ 7.200	2.115 ~ 3.285	0.940 ~ 1.460
2.5	6.750 ± 7.00%	3.375 ± 4.50%	1.500 ± 4.50%
	4.860 ~ 8.640	2.768 ~ 3.983	1.230 ~ 1.770
3	8.100 ± 7.33%	4.050 ± 4.67%	1.800 ± 4.67%
	6.120 ~ 10.080	3.420 ~ 4.680	1.520 ~ 2.080
3.5	9.450 ± 7.67%	4.725 ± 4.83%	2.100 ± 4.83%
	7.380 ~ 11.520	4.073 ~ 5.378	1.810 ~ 2.390
4	10.800 ± 8.00%	5.400 ± 5.00%	2.400 ± 5.00%
	8.640 ~ 12.960	4.725 ~ 6.075	2.100 ~ 2.700
4.5	12.150 ± 8.33%	6.075 ± 5.17%	2.700 ± 5.17%
	9.900 ~ 14.400	5.378 ~ 6.773	2.390 ~ 3.010
5	13.500 ± 8.67%	6.750 ± 5.33%	3.000 ± 5.33%
	11.160 ~ 15.840	6.030 ~ 7.470	2.680 ~ 3.320
6	16.200 ± 9.33%	8.100 ± 5.67%	3.600 ± 5.67%
	13.680 ~ 18.720	7.335 ~ 8.865	3.260 ~ 3.940
7	18.900 ± 10.00%	9.450 ± 6.00%	4.200 ± 6.00%
	16.200 ~ 21.600	8.640 ~ 10.260	3.840 ~ 4.560
8	21.600 ± 10.67%	10.800 ± 6.33%	4.800 ± 6.33%
	18.720 ~ 24.480	9.945 ~ 11.655	4.420 ~ 5.180
9	24.300 ± 11.33%	12.150 ± 6.67%	5.400 ± 6.67%
	24.300 ± 11.33%	12.150 ± 6.67%	5.400 ± 6.67%
10	27.000 ± 12.00%	13.500 ± 7.00%	6.000 ± 7.00%
	23.760 ~ 30.240	12.555 ~ 14.445	5.580 ~ 6.420
15	40.500 ± 12.00%	20.250 ± 7.00%	9.000 ± 7.00%
	35.640 ~ 45.360	18.833 ~ 21.668	8.370 ~ 9.630
20	54.000 ± 12.00%	27.000 ± 7.00%	12.000 ± 7.00%
	47.520 ~ 60.480	25.110 ~ 28.890	11.160 ~ 12.840
30	81.000 ± 12.00%	40.500 ± 7.00%	18.000 ± 7.00%
	71.280 ~ 90.720	37.665 ~ 43.335	16.740 ~ 19.260
40	108.00 ± 12.00%	54.000 ± 7.00%	24.000 ± 7.00%
	95.040 ~ 120.96	50.220 ~ 57.780	22.320 ~ 25.680
50	135.00 ± 12.00%	67.500 ± 7.00%	30.000 ± 7.00%
	118.80 ~ 151.20	62.775 ~ 72.225	27.900 ~ 32.100

**Table 8-10 Long inverse (LI02) Operating time accuracy table**

Unit: s

Operating time multiplier setting (M)	Multiple of input relative to operating time		
	300%	500%	1000%
0.25	0.667 ± 5.50%	0.400 ± 3.75%	0.200 ± 3.75%
	* 0.050 ~ 2.133	* 0.050 ~ 1.000	* 0.050 ~ 0.500
0.5	1.333 ± 5.67%	0.800 ± 3.83%	0.400 ± 3.83%
	* 0.050 ~ 2.844	0.187 ~ 1.413	0.093 ~ 0.707
1	2.667 ± 6.00%	1.600 ± 4.00%	0.800 ± 4.00%
	1.067 ~ 4.267	0.960 ~ 2.240	0.480 ~ 1.120
1.5	4.000 ± 6.33%	2.400 ± 4.17%	1.200 ± 4.17%
	2.311 ~ 5.689	1.733 ~ 3.067	0.867 ~ 1.533
2	5.333 ± 6.67%	3.200 ± 4.33%	1.600 ± 4.33%
	3.556 ~ 7.111	2.507 ~ 3.893	1.253 ~ 1.947
2.5	6.667 ± 7.00%	4.000 ± 4.50%	2.000 ± 4.50%
	4.800 ~ 8.533	3.280 ~ 4.720	1.640 ~ 2.360
3	8.000 ± 7.33%	4.800 ± 4.67%	2.400 ± 4.67%
	6.044 ~ 9.956	4.053 ~ 5.547	2.027 ~ 2.773
3.5	9.333 ± 7.67%	5.600 ± 4.83%	2.800 ± 4.83%
	7.289 ~ 11.378	4.827 ~ 6.373	2.413 ~ 3.187
4	10.667 ± 8.00%	6.400 ± 5.00%	3.200 ± 5.00%
	8.533 ~ 12.800	5.600 ~ 7.200	2.800 ~ 3.600
4.5	12.000 ± 8.33%	7.200 ± 5.17%	3.600 ± 5.17%
	9.778 ~ 14.222	6.373 ~ 8.027	3.187 ~ 4.013
5	13.333 ± 8.67%	8.000 ± 5.33%	4.000 ± 5.33%
	11.022 ~ 15.644	7.147 ~ 8.853	3.573 ~ 4.427
6	16.000 ± 9.33%	9.600 ± 5.67%	4.800 ± 5.67%
	13.511 ~ 18.489	8.693 ~ 10.507	4.347 ~ 5.253
7	18.667 ± 10.00%	11.200 ± 6.00%	5.600 ± 6.00%
	16.000 ~ 21.333	10.240 ~ 12.160	5.120 ~ 6.080
8	21.333 ± 10.67%	12.800 ± 6.33%	6.400 ± 6.33%
	18.489 ~ 24.178	11.787 ~ 13.813	5.893 ~ 6.907
9	24.000 ± 11.33%	14.400 ± 6.67%	7.200 ± 6.67%
	20.978 ~ 27.022	13.333 ~ 15.467	6.667 ~ 7.733
10	26.667 ± 12.00%	16.000 ± 7.00%	8.000 ± 7.00%
	23.467 ~ 29.867	14.880 ~ 17.120	7.440 ~ 8.560
15	40.000 ± 12.00%	24.000 ± 7.00%	12.000 ± 7.00%
	35.200 ~ 44.800	22.320 ~ 25.680	11.160 ~ 12.840
20	53.333 ± 12.00%	32.000 ± 7.00%	16.000 ± 7.00%
	46.933 ~ 59.733	29.760 ~ 34.240	14.880 ~ 17.120
30	80.000 ± 12.00%	48.000 ± 7.00%	24.000 ± 7.00%
	70.400 ~ 89.600	44.640 ~ 51.360	22.320 ~ 25.680
40	106.67 ± 12.00%	64.000 ± 7.00%	32.000 ± 7.00%
	93.867 ~ 119.47	59.520 ~ 68.480	29.760 ~ 34.240
50	133.33 ± 12.00%	80.000 ± 7.00%	40.000 ± 7.00%
	117.33 ~ 149.33	74.400 ~ 85.600	37.200 ~ 42.800

**Table 8-11 Definite time (DT01) Operating time accuracy table**

Unit: s

Operating time multiplier setting (M)	Multiple of input relative to operating time		
	300%	500%	1000%
0.25	0.050 ± 2.56%	0.050 ± 2.56%	0.050 ± 2.56%
	* 0.050 ~ 0.101	* 0.050 ~ 0.101	* 0.050 ~ 0.101
0.5	0.100 ± 2.63%	0.100 ± 2.63%	0.100 ± 2.63%
	0.048 ~ 0.153	0.048 ~ 0.153	0.048 ~ 0.153
1	0.200 ± 2.75%	0.200 ± 2.75%	0.200 ± 2.75%
	0.145 ~ 0.255	0.145 ~ 0.255	0.145 ~ 0.255
1.5	0.300 ± 2.88%	0.300 ± 2.88%	0.300 ± 2.88%
	0.243 ~ 0.358	0.243 ~ 0.358	0.243 ~ 0.358
2	0.400 ± 3.00%	0.400 ± 3.00%	0.400 ± 3.00%
	0.340 ~ 0.460	0.340 ~ 0.460	0.340 ~ 0.460
2.5	0.500 ± 3.13%	0.500 ± 3.13%	0.500 ± 3.13%
	0.438 ~ 0.563	0.438 ~ 0.563	0.438 ~ 0.563
3	0.600 ± 3.25%	0.600 ± 3.25%	0.600 ± 3.25%
	0.535 ~ 0.665	0.535 ~ 0.665	0.535 ~ 0.665
3.5	0.700 ± 3.38%	0.700 ± 3.38%	0.700 ± 3.38%
	0.633 ~ 0.768	0.633 ~ 0.768	0.633 ~ 0.768
4	0.800 ± 3.50%	0.800 ± 3.50%	0.800 ± 3.50%
	0.730 ~ 0.870	0.730 ~ 0.870	0.730 ~ 0.870
4.5	0.900 ± 3.63%	0.900 ± 3.63%	0.900 ± 3.63%
	0.828 ~ 0.973	0.828 ~ 0.973	0.828 ~ 0.973
5	1.000 ± 3.75%	1.000 ± 3.75%	1.000 ± 3.75%
	0.925 ~ 1.075	0.925 ~ 1.075	0.925 ~ 1.075
6	1.200 ± 4.00%	1.200 ± 4.00%	1.200 ± 4.00%
	1.120 ~ 1.280	1.120 ~ 1.280	1.120 ~ 1.280
7	1.400 ± 4.25%	1.400 ± 4.25%	1.400 ± 4.25%
	1.315 ~ 1.485	1.315 ~ 1.485	1.315 ~ 1.485
8	1.600 ± 4.50%	1.600 ± 4.50%	1.600 ± 4.50%
	1.510 ~ 1.690	1.510 ~ 1.690	1.510 ~ 1.690
9	1.800 ± 4.75%	1.800 ± 4.75%	1.800 ± 4.75%
	1.705 ~ 1.895	1.705 ~ 1.890	1.705 ~ 1.895
10	2.000 ± 5.00%	2.000 ± 5.00%	2.000 ± 5.00%
	1.900 ~ 2.100	1.900 ~ 2.100	1.900 ~ 2.100
15	3.000 ± 5.00%	3.000 ± 5.00%	3.000 ± 5.00%
	2.850 ~ 3.150	2.850 ~ 3.150	2.850 ~ 3.150
20	4.000 ± 5.00%	4.000 ± 5.00%	4.000 ± 5.00%
	3.800 ~ 4.200	3.800 ~ 4.200	3.800 ~ 4.200
30	6.000 ± 5.00%	6.000 ± 5.00%	6.000 ± 5.00%
	5.700 ~ 6.300	5.700 ~ 6.300	5.700 ~ 6.300
40	8.000 ± 5.00%	8.000 ± 5.00%	8.000 ± 5.00%
	7.600 ~ 8.400	7.600 ~ 8.400	7.600 ~ 8.400
50	10.000 ± 5.00%	10.000 ± 5.00%	10.000 ± 5.00%
	9.500 ~ 10.500	9.500 ~ 10.500	9.500 ~ 10.500

**Table 8-12 IEEE Moderate inverse (NI11) Operating time accuracy table**

Unit: s

Operating time multiplier setting (M)	Multiple of input relative to operating time		
	300%	500%	1000%
0.25	0.061 ± 5.50%	0.042 ± 3.75%	0.030 ± 0.05
	* 0.050 ~ 0.195	* 0.050 ~ 0.106	* 0.050 ~ 0.080
0.5	0.122 ± 5.67%	0.084 ± 3.83%	0.060 ± 0.05
	* 0.050 ~ 0.259	* 0.050 ~ 0.149	* 0.050 ~ 0.110
1	0.243 ± 6.00%	0.169 ± 4.00%	0.121 ± 0.05
	0.097 ~ 0.389	0.101 ~ 0.236	0.071 ~ 0.171
1.5	0.365 ± 6.33%	0.253 ± 4.17%	0.181 ± 4.17%
	0.211 ~ 0.519	0.183 ~ 0.324	0.131 ~ 0.231
2	0.486 ± 6.67%	0.338 ± 4.33%	0.241 ± 4.33%
	0.324 ~ 0.649	0.265 ~ 0.411	0.189 ~ 0.294
2.5	0.608 ± 7.00%	0.422 ± 4.50%	0.302 ± 4.50%
	0.438 ~ 0.778	0.346 ~ 0.498	0.247 ~ 0.356
3	0.730 ± 7.33%	0.506 ± 4.67%	0.362 ± 4.67%
	0.551 ~ 0.908	0.428 ~ 0.585	0.306 ~ 0.418
3.5	0.851 ± 7.67%	0.591 ± 4.83%	0.422 ± 4.83%
	0.665 ~ 1.038	0.509 ~ 0.673	0.364 ~ 0.481
4	0.973 ± 8.00%	0.675 ± 5.00%	0.483 ± 5.00%
	0.778 ~ 1.167	0.591 ~ 0.760	0.422 ~ 0.543
4.5	1.094 ± 8.33%	0.760 ± 5.17%	0.543 ± 5.17%
	0.892 ~ 1.297	0.673 ~ 0.847	0.481 ~ 0.605
5	1.216 ± 8.67%	0.844 ± 5.33%	0.603 ± 5.33%
	1.005 ~ 1.427	0.754 ~ 0.934	0.539 ~ 0.668
6	1.459 ± 9.33%	1.013 ± 5.67%	0.724 ± 5.67%
	1.232 ~ 1.686	0.917 ~ 1.109	0.656 ~ 0.792
7	1.703 ± 10.00%	1.182 ± 6.00%	0.845 ± 6.00%
	1.459 ~ 1.946	1.081 ~ 1.283	0.772 ~ 0.917
8	1.946 ± 10.67%	1.351 ± 6.33%	0.965 ± 6.33%
	1.686 ~ 2.205	1.244 ~ 1.458	0.889 ~ 1.042
9	2.189 ± 11.33%	1.519 ± 6.67%	1.086 ± 6.67%
	1.913 ~ 2.465	1.407 ~ 1.632	1.006 ~ 1.167
10	2.432 ± 12.00%	1.688 ± 7.00%	1.207 ± 7.00%
	2.140 ~ 2.724	1.570 ~ 1.807	1.122 ~ 1.291
15	3.648 ± 12.00%	2.532 ± 7.00%	1.810 ± 7.00%
	3.211 ~ 4.086	2.355 ~ 2.710	1.683 ~ 1.937
20	4.864 ± 12.00%	3.377 ± 7.00%	2.414 ± 7.00%
	4.281 ~ 5.448	3.140 ~ 3.613	2.245 ~ 2.582
30	7.297 ± 12.00%	5.065 ± 7.00%	3.620 ± 7.00%
	6.421 ~ 8.172	4.710 ~ 5.420	3.367 ~ 3.874
40	9.729 ± 12.00%	6.753 ± 7.00%	4.827 ± 7.00%
	8.561 ~ 10.896	6.281 ~ 7.226	4.489 ~ 5.165
50	12.161 ± 12.00%	8.442 ± 7.00%	6.034 ± 7.00%
	10.702 ~ 13.620	7.851 ~ 9.033	5.611 ~ 6.456

**Table 8-13 IEEE Very inverse (EI11) Operating time accuracy table**

Unit: s

Operating time multiplier setting (M)	Multiple of input relative to operating time		
	300%	500%	1000%
0.25	0.074 ± 5.50%	0.033 ± 0.05	0.017 ± 0.05
	* 0.050 ~ 0.235	* 0.050 ~ 0.082	* 0.050 ~ 0.067
0.5	0.147 ± 5.67%	0.065 ± 3.83%	0.034 ± 0.05
	* 0.050 ~ 0.314	* 0.050 ~ 0.116	* 0.050 ~ 0.084
1	0.294 ± 6.00%	0.131 ± 4.00%	0.069 ± 0.05
	0.118 ~ 0.471	0.078 ~ 0.183	* 0.050 ~ 0.119
1.5	0.441 ± 6.33%	0.196 ± 4.17%	0.103 ± 0.05
	0.255 ~ 0.628	0.142 ~ 0.251	0.053 ~ 0.153
2	0.588 ± 6.67%	0.262 ± 4.33%	0.138 ± 0.05
	0.392 ~ 0.785	0.205 ~ 0.318	0.088 ~ 0.188
2.5	0.736 ± 7.00%	0.327 ± 4.50%	0.172 ± 0.05
	0.530 ~ 0.942	0.268 ~ 0.386	0.122 ~ 0.222
3	0.883 ± 7.33%	0.392 ± 4.67%	0.207 ± 0.05
	0.667 ~ 1.098	0.331 ~ 0.453	0.157 ~ 0.257
3.5	1.030 ± 7.67%	0.458 ± 4.83%	0.241 ± 0.05
	0.804 ~ 1.255	0.395 ~ 0.521	0.191 ~ 0.291
4	1.177 ± 8.00%	0.523 ± 5.00%	0.276 ± 0.05
	0.942 ~ 1.412	0.458 ~ 0.589	0.226 ~ 0.326
4.5	1.324 ± 8.33%	0.589 ± 5.17%	0.310 ± 0.05
	1.079 ~ 1.569	0.521 ~ 0.656	0.260 ~ 0.360
5	1.471 ± 8.67%	0.654 ± 5.33%	0.345 ± 0.05
	1.216 ~ 1.726	0.584 ~ 0.724	0.295 ~ 0.395
6	1.765 ± 9.33%	0.785 ± 5.67%	0.413 ± 0.05
	1.491 ~ 2.040	0.711 ~ 0.859	0.363 ~ 0.463
7	2.060 ± 10.00%	0.916 ± 6.00%	0.482 ± 0.05
	1.765 ~ 2.354	0.837 ~ 0.994	0.432 ~ 0.532
8	2.354 ± 10.67%	1.046 ± 6.33%	0.551 ± 0.05
	2.040 ~ 2.668	0.964 ~ 1.129	0.501 ~ 0.601
9	2.648 ± 11.33%	1.177 ± 6.67%	0.620 ± 0.05
	2.315 ~ 2.981	1.090 ~ 1.264	0.570 ~ 0.670
10	2.942 ± 12.00%	1.308 ± 7.00%	0.689 ± 0.05
	2.589 ~ 3.295	1.217 ~ 1.400	0.639 ~ 0.739
15	4.413 ± 12.00%	1.962 ± 7.00%	1.034 ± 7.00%
	3.884 ~ 4.943	1.825 ~ 2.099	0.961 ~ 1.106
20	5.885 ± 12.00%	2.616 ± 7.00%	1.378 ± 7.00%
	5.178 ~ 6.591	2.433 ~ 2.799	1.282 ~ 1.475
30	8.827 ± 12.00%	3.924 ± 7.00%	2.067 ± 7.00%
	7.768 ~ 9.886	3.650 ~ 4.199	1.923 ~ 2.212
40	11.769 ± 12.00%	5.232 ± 7.00%	2.756 ± 7.00%
	10.357 ~ 13.181	4.866 ~ 5.599	2.563 ~ 2.949
50	14.711 ± 12.00%	6.540 ± 7.00%	3.445 ± 7.00%
	12.946 ~ 16.477	6.083 ~ 6.998	3.204 ~ 3.687

**Table 8-14 IEEE Extremely inverse (EI12) Operating time accuracy table**

Unit: s

Operating time multiplier setting (M)	Multiple of input relative to operating time		
	300%	500%	1000%
0.25	0.091 ± 5.50%	0.032 ± 0.05	0.010 ± 0.05
	* 0.050 ~ 0.292	* 0.050 ~ 0.082	* 0.050 ~ 0.060
0.5	0.182 ± 5.67%	0.065 ± 3.83%	0.020 ± 0.05
	* 0.050 ~ 0.389	* 0.050 ~ 0.115	* 0.050 ~ 0.070
1	0.365 ± 6.00%	0.130 ± 4.00%	0.041 ± 0.05
	0.146 ~ 0.583	0.078 ~ 0.182	* 0.050 ~ 0.091
1.5	0.547 ± 6.33%	0.195 ± 4.17%	0.061 ± 0.05
	0.316 ~ 0.778	0.140 ~ 0.249	* 0.050 ~ 0.111
2	0.729 ± 6.67%	0.259 ± 4.33%	0.081 ± 0.05
	0.486 ~ 0.972	0.203 ~ 0.316	* 0.050 ~ 0.131
2.5	0.912 ± 7.00%	0.324 ± 4.50%	0.102 ± 0.05
	0.656 ~ 1.167	0.266 ~ 0.383	0.052 ~ 0.152
3	1.094 ± 7.33%	0.389 ± 4.67%	0.122 ± 0.05
	0.827 ~ 1.361	0.328 ~ 0.450	0.072 ~ 0.172
3.5	1.276 ± 7.67%	0.454 ± 4.83%	0.142 ± 0.05
	0.997 ~ 1.556	0.391 ~ 0.517	0.092 ~ 0.192
4	1.459 ± 8.00%	0.519 ± 5.00%	0.163 ± 0.05
	1.167 ~ 1.750	0.454 ~ 0.584	0.113 ~ 0.213
4.5	1.641 ± 8.33%	0.584 ± 5.17%	0.183 ± 0.05
	1.337 ~ 1.945	0.517 ~ 0.651	0.133 ~ 0.233
5	1.823 ± 8.67%	0.648 ± 5.33%	0.203 ± 0.05
	1.507 ~ 2.139	0.579 ~ 0.718	0.153 ~ 0.253
6	2.188 ± 9.33%	0.778 ± 5.67%	0.244 ± 0.05
	1.848 ~ 2.528	0.705 ~ 0.851	0.194 ~ 0.294
7	2.553 ± 10.00%	0.908 ± 6.00%	0.285 ± 0.05
	2.188 ~ 2.917	0.830 ~ 0.985	0.235 ~ 0.335
8	2.917 ± 10.67%	1.037 ± 6.33%	0.325 ± 0.05
	2.528 ~ 3.306	0.955 ~ 1.119	0.275 ~ 0.375
9	3.282 ± 11.33%	1.167 ± 6.67%	0.366 ± 0.05
	2.869 ~ 3.695	1.081 ~ 1.253	0.316 ~ 0.416
10	3.647 ± 12.00%	1.297 ± 7.00%	0.407 ± 0.05
	3.209 ~ 4.084	1.206 ~ 1.387	0.357 ~ 0.457
15	5.470 ± 12.00%	1.945 ± 7.00%	0.610 ± 0.05
	4.814 ~ 6.126	1.809 ~ 2.081	0.560 ~ 0.660
20	7.293 ± 12.00%	2.593 ± 7.00%	0.813 ± 7.00%
	6.418 ~ 8.169	2.412 ~ 2.775	0.756 ~ 0.870
30	10.940 ± 12.00%	3.890 ± 7.00%	1.220 ± 7.00%
	9.627 ~ 12.253	3.618 ~ 4.162	1.134 ~ 1.305
40	14.587 ± 12.00%	5.187 ± 7.00%	1.626 ± 7.00%
	12.836 ~ 16.337	4.824 ~ 5.550	1.512 ~ 1.740
50	18.234 ± 12.00%	6.484 ± 7.00%	2.033 ± 7.00%
	16.045 ~ 20.422	6.030 ~ 6.937	1.890 ~ 2.175

**Table 8-15 Normal inverse (NI21) Operating time accuracy table**

Unit: s

Operating time multiplier setting (M)	Multiple of input relative to operating time		
	300%	500%	1000%
0.25	0.139 ± 5.50%	0.096 ± 3.75%	0.070 ± 3.75%
	* 0.050 ~ 0.444	* 0.050 ~ 0.241	* 0.050 ~ 0.174
0.5	0.277 ± 5.67%	0.193 ± 3.83%	0.139 ± 3.83%
	* 0.050 ~ 0.592	* 0.050 ~ 0.341	* 0.050 ~ 0.246
1	0.555 ± 6.00%	0.386 ± 4.00%	0.279 ± 4.00%
	0.222 ~ 0.888	0.231 ~ 0.540	0.167 ~ 0.390
1.5	0.832 ± 6.33%	0.578 ± 4.17%	0.418 ± 4.17%
	0.481 ~ 1.184	0.418 ~ 0.739	0.302 ~ 0.534
2	1.110 ± 6.67%	0.771 ± 4.33%	0.557 ± 4.33%
	0.740 ~ 1.480	0.604 ~ 0.938	0.437 ~ 0.678
2.5	1.387 ± 7.00%	0.964 ± 4.50%	0.697 ± 4.50%
	0.999 ~ 1.776	0.790 ~ 1.137	0.571 ~ 0.822
3	1.665 ± 7.33%	1.157 ± 4.67%	0.836 ± 4.67%
	1.258 ~ 2.072	0.977 ~ 1.337	0.706 ~ 0.966
3.5	1.942 ± 7.67%	1.350 ± 4.83%	0.976 ± 4.83%
	1.517 ~ 2.368	1.163 ~ 1.536	0.841 ~ 1.110
4	2.220 ± 8.00%	1.542 ± 5.00%	1.115 ± 5.00%
	1.776 ~ 2.664	1.350 ~ 1.735	0.976 ~ 1.254
4.5	2.497 ± 8.33%	1.735 ± 5.17%	1.254 ± 5.17%
	2.035 ~ 2.959	1.536 ~ 1.934	1.110 ~ 1.398
5	2.775 ± 8.67%	1.928 ± 5.33%	1.394 ± 5.33%
	2.294 ~ 3.255	1.722 ~ 2.134	1.245 ~ 1.542
6	3.329 ± 9.33%	2.314 ± 5.67%	1.672 ± 5.67%
	2.812 ~ 3.847	2.095 ~ 2.532	1.514 ~ 1.830
7	3.884 ± 10.00%	2.699 ± 6.00%	1.951 ± 6.00%
	3.329 ~ 4.439	2.468 ~ 2.930	1.784 ~ 2.118
8	4.439 ± 10.67%	3.085 ± 6.33%	2.230 ± 6.33%
	3.847 ~ 5.031	2.841 ~ 3.329	2.053 ~ 2.406
9	4.994 ± 11.33%	3.470 ± 6.67%	2.509 ± 6.67%
	4.365 ~ 5.623	3.213 ~ 3.727	2.323 ~ 2.695
10	5.549 ± 12.00%	3.856 ± 7.00%	2.787 ± 7.00%
	4.883 ~ 6.215	3.586 ~ 4.126	2.592 ~ 2.983
15	8.324 ± 12.00%	5.784 ± 7.00%	4.181 ± 7.00%
	7.325 ~ 9.322	5.379 ~ 6.189	3.888 ~ 4.474
20	11.098 ± 12.00%	7.712 ± 7.00%	5.575 ± 7.00%
	9.766 ~ 12.430	7.172 ~ 8.252	5.185 ~ 5.965
30	16.647 ± 12.00%	11.568 ± 7.00%	8.362 ± 7.00%
	14.649 ~ 18.645	10.758 ~ 12.377	7.777 ~ 8.948
40	22.196 ± 12.00%	15.424 ± 7.00%	11.150 ± 7.00%
	19.533 ~ 24.860	14.344 ~ 16.503	10.369 ~ 11.930
50	27.745 ± 12.00%	19.279 ± 7.00%	13.937 ± 7.00%
	24.416 ~ 31.075	17.930 ~ 20.629	12.962 ~ 14.913

**Table 8-16 Very inverse (VI21) Operating time accuracy table**

Unit: s

Operating time multiplier setting (M)	Multiple of input relative to operating time		
	300%	500%	1000%
0.25	0.210 ± 5.50%	0.110 ± 3.75%	0.054 ± 3.75%
	* 0.050 ~ 0.672	* 0.050 ~ 0.275	* 0.050 ~ 0.136
0.5	0.420 ± 5.67%	0.220 ± 3.83%	0.109 ± 3.83%
	* 0.050 ~ 0.896	0.051 ~ 0.389	* 0.050 ~ 0.192
1	0.840 ± 6.00%	0.440 ± 4.00%	0.218 ± 4.00%
	0.336 ~ 1.344	0.264 ~ 0.616	0.131 ~ 0.305
1.5	1.260 ± 6.33%	0.660 ± 4.17%	0.327 ± 4.17%
	0.728 ~ 1.792	0.477 ~ 0.843	0.236 ~ 0.417
2	1.680 ± 6.67%	0.880 ± 4.33%	0.436 ± 4.33%
	1.120 ~ 2.240	0.689 ~ 1.071	0.341 ~ 0.530
2.5	2.100 ± 7.00%	1.100 ± 4.50%	0.544 ± 4.50%
	1.512 ~ 2.688	0.902 ~ 1.298	0.446 ~ 0.642
3	2.520 ± 7.33%	1.320 ± 4.67%	0.653 ± 4.67%
	1.904 ~ 3.136	1.115 ~ 1.525	0.552 ~ 0.755
3.5	2.940 ± 7.67%	1.540 ± 4.83%	0.762 ± 4.83%
	2.296 ~ 3.584	1.327 ~ 1.753	0.657 ~ 0.867
4	3.360 ± 8.00%	1.760 ± 5.00%	0.871 ± 5.00%
	2.688 ~ 4.032	1.540 ~ 1.980	0.762 ~ 0.980
4.5	3.780 ± 8.33%	1.980 ± 5.17%	0.980 ± 5.17%
	3.080 ~ 4.480	1.753 ~ 2.207	0.867 ~ 1.093
5	4.200 ± 8.67%	2.200 ± 5.33%	1.089 ± 5.33%
	3.472 ~ 4.928	1.965 ~ 2.435	0.973 ~ 1.205
6	5.040 ± 9.33%	2.640 ± 5.67%	1.307 ± 5.67%
	4.256 ~ 5.824	2.391 ~ 2.889	1.183 ~ 1.430
7	5.880 ± 10.00%	3.080 ± 6.00%	1.524 ± 6.00%
	5.040 ~ 6.720	2.816 ~ 3.344	1.394 ~ 1.655
8	6.720 ± 10.67%	3.520 ± 6.33%	1.742 ± 6.33%
	5.824 ~ 7.616	3.241 ~ 3.799	1.604 ~ 1.880
9	7.560 ± 11.33%	3.960 ± 6.67%	1.960 ± 6.67%
	6.608 ~ 8.512	3.667 ~ 4.253	1.815 ~ 2.105
10	8.400 ± 12.00%	4.400 ± 7.00%	2.178 ± 7.00%
	7.392 ~ 9.408	4.092 ~ 4.708	2.025 ~ 2.330
15	12.600 ± 12.00%	6.600 ± 7.00%	3.267 ± 7.00%
	11.088 ~ 14.112	6.138 ~ 7.062	3.038 ~ 3.495
20	16.800 ± 12.00%	8.800 ± 7.00%	4.356 ± 7.00%
	14.784 ~ 18.816	8.184 ~ 9.416	4.051 ~ 4.660
30	25.200 ± 12.00%	13.200 ± 7.00%	6.533 ± 7.00%
	22.176 ~ 28.224	12.276 ~ 14.124	6.076 ~ 6.991
40	33.600 ± 12.00%	17.600 ± 7.00%	8.711 ± 7.00%
	29.568 ~ 37.632	16.368 ~ 18.832	8.101 ~ 9.321
50	42.000 ± 12.00%	22.000 ± 7.00%	10.889 ± 7.00%
	36.960 ~ 47.040	20.460 ~ 23.540	10.127 ~ 11.651

**Table 8-17 Long inverse (LI21) Operating time accuracy table**

Unit: s

Operating time multiplier setting (M)	Multiple of input relative to operating time		
	300%	500%	1000%
0.25	0.750 ± 5.50%	0.375 ± 3.75%	0.167 ± 3.75%
	* 0.050 ~ 2.400	* 0.050 ~ 0.938	* 0.050 ~ 0.417
0.5	1.500 ± 5.67%	0.750 ± 3.83%	0.333 ± 3.83%
	* 0.050 ~ 3.200	0.175 ~ 1.325	0.078 ~ 0.589
1	3.000 ± 6.00%	1.500 ± 4.00%	0.667 ± 4.00%
	1.200 ~ 4.800	0.900 ~ 2.100	0.400 ~ 0.933
1.5	4.500 ± 6.33%	2.250 ± 4.17%	1.000 ± 4.17%
	2.600 ~ 6.400	1.625 ~ 2.875	0.722 ~ 1.278
2	6.000 ± 6.67%	3.000 ± 4.33%	1.333 ± 4.33%
	4.000 ~ 8.000	2.350 ~ 3.650	1.044 ~ 1.622
2.5	7.500 ± 7.00%	3.750 ± 4.50%	1.667 ± 4.50%
	5.400 ~ 9.600	3.075 ~ 4.425	1.367 ~ 1.967
3	9.000 ± 7.33%	4.500 ± 4.67%	2.000 ± 4.67%
	6.800 ~ 11.200	3.800 ~ 5.200	1.689 ~ 2.311
3.5	10.500 ± 7.67%	5.250 ± 4.83%	2.333 ± 4.83%
	8.200 ~ 12.800	4.525 ~ 5.975	2.011 ~ 2.656
4	12.000 ± 8.00%	6.000 ± 5.00%	2.667 ± 5.00%
	9.600 ~ 14.400	5.250 ~ 6.750	2.333 ~ 3.000
4.5	13.500 ± 8.33%	6.750 ± 5.17%	3.000 ± 5.17%
	11.000 ~ 16.000	5.975 ~ 7.525	2.656 ~ 3.344
5	15.000 ± 8.67%	7.500 ± 5.33%	3.333 ± 5.33%
	12.400 ~ 17.600	6.700 ~ 8.300	2.978 ~ 3.689
6	18.000 ± 9.33%	9.000 ± 5.67%	4.000 ± 5.67%
	15.200 ~ 20.800	8.150 ~ 9.850	3.622 ~ 4.378
7	21.000 ± 10.00%	10.500 ± 6.00%	4.667 ± 6.00%
	18.000 ~ 24.000	9.600 ~ 11.400	4.267 ~ 5.067
8	24.000 ± 10.67%	12.000 ± 6.33%	5.333 ± 6.33%
	20.800 ~ 27.200	11.050 ~ 12.950	4.911 ~ 5.756
9	27.000 ± 11.33%	13.500 ± 6.67%	6.000 ± 6.67%
	23.600 ~ 30.400	12.500 ~ 14.500	5.556 ~ 6.444
10	30.000 ± 12.00%	15.000 ± 7.00%	6.667 ± 7.00%
	26.400 ~ 33.600	13.950 ~ 16.050	6.200 ~ 7.133
15	45.000 ± 12.00%	22.500 ± 7.00%	10.000 ± 7.00%
	39.600 ~ 50.400	20.925 ~ 24.075	9.300 ~ 10.700
20	60.000 ± 12.00%	30.000 ± 7.00%	13.333 ± 7.00%
	52.800 ~ 67.200	27.900 ~ 32.100	12.400 ~ 14.267
30	90.000 ± 12.00%	45.000 ± 7.00%	20.000 ± 7.00%
	79.200 ~ 100.80	41.850 ~ 48.150	18.600 ~ 21.400
40	120.00 ± 12.00%	60.000 ± 7.00%	26.667 ± 7.00%
	105.60 ~ 134.4	55.800 ~ 64.200	24.800 ~ 28.533
50	150.00 ± 12.00%	75.000 ± 7.00%	33.333 ± 7.00%
	132.00 ~ 168.00	69.750 ~ 80.250	31.000 ~ 35.667

**Table 8-18 Korean Normal inverse (NI31) Operating time accuracy table**

Unit: s

Operating time multiplier setting (M)	Multiple of input relative to operating time		
	300%	500%	1000%
0.25	0.134 ± 5.50%	0.095 ± 3.75%	0.069 ± 3.75%
	* 0.050 ~ 0.430	* 0.050 ~ 0.236	* 0.050 ~ 0.172
0.5	0.269 ± 5.67%	0.189 ± 3.83%	0.138 ± 3.83%
	* 0.050 ~ 0.573	* 0.050 ~ 0.334	* 0.050 ~ 0.243
1	0.537 ± 6.00%	0.378 ± 4.00%	0.275 ± 4.00%
	0.215 ~ 0.859	0.227 ~ 0.530	0.165 ~ 0.386
1.5	0.806 ± 6.33%	0.567 ± 4.17%	0.413 ± 4.17%
	0.466 ~ 1.146	0.410 ~ 0.725	0.298 ~ 0.528
2	1.074 ± 6.67%	0.757 ± 4.33%	0.551 ± 4.33%
	0.716 ~ 1.432	0.593 ~ 0.920	0.431 ~ 0.670
2.5	1.343 ± 7.00%	0.946 ± 4.50%	0.689 ± 4.50%
	0.967 ~ 1.719	0.775 ~ 1.116	0.565 ~ 0.812
3	1.611 ± 7.33%	1.135 ± 4.67%	0.826 ± 4.67%
	1.218 ~ 2.005	0.958 ~ 1.311	0.698 ~ 0.955
3.5	1.880 ± 7.67%	1.324 ± 4.83%	0.964 ± 4.83%
	1.468 ~ 2.292	1.141 ~ 1.507	0.831 ~ 1.097
4	2.149 ± 8.00%	1.513 ± 5.00%	1.102 ± 5.00%
	1.719 ~ 2.578	1.324 ~ 1.702	0.964 ~ 1.239
4.5	2.417 ± 8.33%	1.702 ± 5.17%	1.239 ± 5.17%
	1.970 ~ 2.865	1.507 ~ 1.898	1.097 ~ 1.382
5	2.686 ± 8.67%	1.891 ± 5.33%	1.377 ± 5.33%
	2.220 ~ 3.151	1.690 ~ 2.093	1.230 ~ 1.524
6	3.223 ± 9.33%	2.270 ± 5.67%	1.652 ± 5.67%
	2.722 ~ 3.724	2.055 ~ 2.484	1.496 ~ 1.808
7	3.760 ± 10.00%	2.648 ± 6.00%	1.928 ± 6.00%
	3.223 ~ 4.297	2.421 ~ 2.875	1.763 ~ 2.093
8	4.297 ± 10.67%	3.026 ± 6.33%	2.203 ± 6.33%
	3.724 ~ 4.870	2.787 ~ 3.266	2.029 ~ 2.378
9	4.834 ± 11.33%	3.404 ± 6.67%	2.479 ± 6.67%
	4.226 ~ 5.443	3.152 ~ 3.657	2.295 ~ 2.662
10	5.372 ± 12.00%	3.783 ± 7.00%	2.754 ± 7.00%
	4.727 ~ 6.016	3.518 ~ 4.047	2.561 ~ 2.947
15	8.057 ± 12.00%	5.674 ± 7.00%	4.131 ± 7.00%
	7.090 ~ 9.024	5.277 ~ 6.071	3.842 ~ 4.420
20	10.743 ± 12.00%	7.565 ± 7.00%	5.508 ± 7.00%
	9.454 ~ 12.032	7.036 ~ 8.095	5.123 ~ 5.894
30	16.115 ± 12.00%	11.348 ± 7.00%	8.262 ± 7.00%
	14.181 ~ 18.048	10.554 ~ 12.142	7.684 ~ 8.840
40	21.486 ± 12.00%	15.131 ± 7.00%	11.016 ± 7.00%
	18.908 ~ 24.064	14.071 ~ 16.190	10.245 ~ 11.787
50	26.858 ± 12.00%	18.913 ± 7.00%	13.770 ± 7.00%
	23.635 ~ 30.080	17.589 ~ 20.237	12.806 ~ 14.734

**Table 8-19 Korean Very inverse (VI31) Operating time accuracy table**

Unit: s

Operating time multiplier setting (M)	Multiple of input relative to operating time		
	300%	500%	1000%
0.25	0.160 ± 5.50%	0.072 ± 3.75%	0.038 ± 3.75%
	* 0.050 ~ 0.511	* 0.050 ~ 0.181	* 0.050 ~ 0.096
0.5	0.319 ± 5.67%	0.144 ± 3.83%	0.077 ± 3.83%
	* 0.050 ~ 0.681	* 0.050 ~ 0.255	* 0.050 ~ 0.136
1	0.638 ± 6.00%	0.289 ± 4.00%	0.154 ± 4.00%
	0.255 ~ 1.021	0.173 ~ 0.405	0.092 ~ 0.215
1.5	0.958 ± 6.33%	0.433 ± 4.17%	0.230 ± 4.17%
	0.553 ~ 1.362	0.313 ~ 0.554	0.166 ~ 0.294
2	1.277 ± 6.67%	0.578 ± 4.33%	0.307 ± 4.33%
	0.851 ~ 1.702	0.453 ~ 0.703	0.241 ~ 0.374
2.5	1.596 ± 7.00%	0.722 ± 4.50%	0.384 ± 4.50%
	1.149 ~ 2.043	0.592 ~ 0.853	0.315 ~ 0.453
3	1.915 ± 7.33%	0.867 ± 4.67%	0.461 ± 4.67%
	1.447 ~ 2.383	0.732 ~ 1.002	0.389 ~ 0.533
3.5	2.234 ± 7.67%	1.011 ± 4.83%	0.538 ± 4.83%
	1.745 ~ 2.724	0.872 ~ 1.151	0.463 ~ 0.612
4	2.554 ± 8.00%	1.156 ± 5.00%	0.614 ± 5.00%
	2.043 ~ 3.064	1.011 ~ 1.300	0.538 ~ 0.691
4.5	2.873 ± 8.33%	1.300 ± 5.17%	0.691 ± 5.17%
	2.341 ~ 3.405	1.151 ~ 1.450	0.612 ~ 0.771
5	3.192 ± 8.67%	1.445 ± 5.33%	0.768 ± 5.33%
	2.639 ~ 3.745	1.291 ~ 1.599	0.686 ~ 0.850
6	3.830 ± 9.33%	1.734 ± 5.67%	0.922 ± 5.67%
	3.235 ~ 4.426	1.570 ~ 1.898	0.835 ~ 1.009
7	4.469 ± 10.00%	2.023 ± 6.00%	1.075 ± 6.00%
	3.830 ~ 5.107	1.850 ~ 2.196	0.983 ~ 1.168
8	5.107 ± 10.67%	2.312 ± 6.33%	1.229 ± 6.33%
	4.426 ~ 5.788	2.129 ~ 2.495	1.132 ~ 1.326
9	5.746 ± 11.33%	2.601 ± 6.67%	1.383 ± 6.67%
	5.022 ~ 6.469	2.408 ~ 2.794	1.280 ~ 1.485
10	6.384 ± 12.00%	2.890 ± 7.00%	1.536 ± 7.00%
	5.618 ~ 7.150	2.688 ~ 3.092	1.429 ~ 1.644
15	9.576 ± 12.00%	4.335 ± 7.00%	2.304 ± 7.00%
	8.427 ~ 10.725	4.031 ~ 4.638	2.143 ~ 2.466
20	12.768 ± 12.00%	5.780 ± 7.00%	3.072 ± 7.00%
	11.236 ~ 14.300	5.375 ~ 6.184	2.857 ~ 3.287
30	19.152 ± 12.00%	8.670 ± 7.00%	4.609 ± 7.00%
	16.854 ~ 21.450	8.063 ~ 9.276	4.286 ~ 4.931
40	25.536 ± 12.00%	11.559 ± 7.00%	6.145 ± 7.00%
	22.471 ~ 28.600	10.750 ~ 12.369	5.715 ~ 6.575
50	31.920 ± 12.00%	14.449 ± 7.00%	7.681 ± 7.00%
	28.089 ~ 35.750	13.438 ~ 15.461	7.143 ~ 8.219

**Table 8-20 Reset time characteristic**

Input: Setting value × 300% → 0

Reset time setting (Rst. Chr.)	Output contact	Reset time of internal timer counter
DT: Definite time (200 ms)	200 ms ± 25 ms	Instant
IDMT	200 ms ± 25 ms	About 8 s
INST: Instant (50 ms)	50 ms or less	Instant

◆How to read the operating time accuracy table

\* “300,500%,” and “1000%” which are listed in the table are a multiple to be applied to the current setting value, respectively.

\* Figures in the upper row show a theoretical operating time and its error range while those in the lower row, error range in absolute terms (see the equations below).

a. When operating time multiple $M \leq 10$	b. When operating time multiple $M > 10$
$\varepsilon = \frac{T_M - \frac{M}{10} \cdot T_{10}}{T_{10}} \cdot 100$	$\varepsilon = \frac{T_M - \frac{M}{10} \cdot T_{10}}{\frac{M}{10} \cdot T_{10}} \cdot 100$

$T_{10}$  : Nominal operating time at reference operating time setting ( $M=10$ )

$T_M$  : Measured operating time at the operating time multiplier setting  $M$

$\varepsilon$  : Error (%)

$M$  : Operating time multiplier setting

Note that if the error range which has been calculated from the above equation is smaller than the lower error limits of ±50 ms, these smaller error limits are taken as an error range.

\* The underlined 50 ms marked with \* in the tables is a fixed time, as the minimum operating time.

## 8.2. Directional ground (earth) fault element

In CFP1-A42D1 and CFP1-A43D1 relay, 2 types of directional ground (earth) fault elements are incorporated, and rapid detection of ground (earth) fault is possible. In addition, a variety of operations & reset characteristics are provided. Furthermore, second harmonic restraint is incorporated to prevent unnecessary operation due to transformer magnetizing inrush current.

Apparatus No.	Display name	Protective function
67G	DIRG1	Instantaneous directional ground fault element
	DIRG2	Instantaneous directional ground fault element with 2 <sup>nd</sup> harmonic restraint

8.2.1. DIRG1 element

Fig. 8-12 shows the internal function blocks of DIRG1 element.

The DIRG1 element outputs a definitive signal after a preset time of the operation timer (Ope. Time) has passed, when

- a) the zero sequence current is greater than or equal to the setting value (Ope. Curt.) , AND
- b) the zero sequence voltage is greater than or equal to the setting value (Ope. Volt.), AND
- c) the phase difference between the zero-seq. current and zero-seq. voltage is within the operating area.

An off-delay timer of 200 ms is added in order to prevent chattering of the output contacts.

Furthermore, this element is enabled only when the setting of Use/Non-use of DIRG1 (DIRG1 EN) is set to ON. Therefore, when this element is not used, unnecessary operation can be prevented by setting to OFF. It is not necessary to adjust any other settings with regard to DIRG1 element.

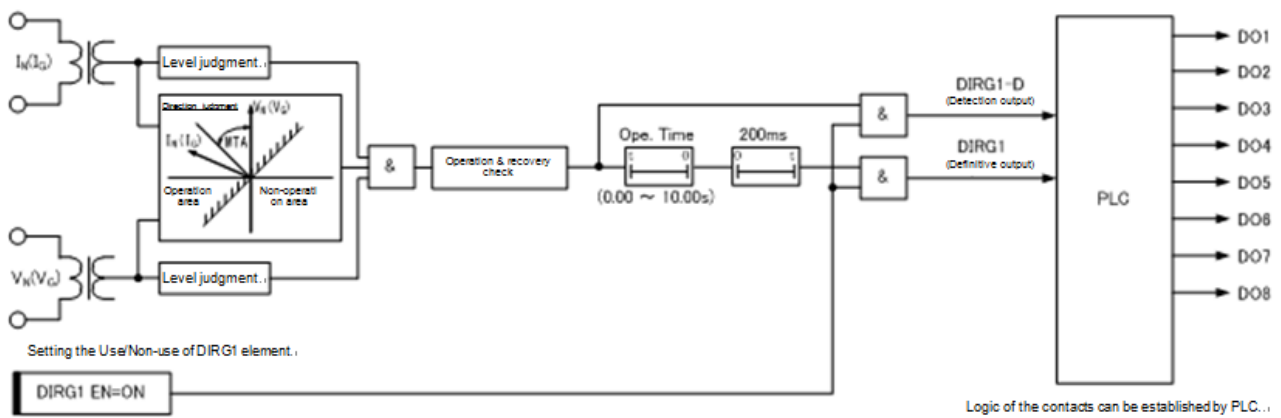

Fig. 8-12 Internal function block diagram of DIRG1 element

**Table 8-21 Setting items of DIRG1 element (CFP1-A42D1)**

Display name	Setting parameter	Setting		Description
		Range of setting	step	
DIRG	MT Angle	0° ~ 90° (Lead angle)	1°	Setting the maximum sensitivity angle common to DIRG1 and DIRG2
DIRG1	DIRG1 EN	OFF, ON	-	OFF: Non-use, ON: Use When this element is used, set to ON.
	Ope. Volt	2.0 ~ 100.0 V	0.1 V	Operating voltage
	Ope. Curt.	1.0 ~ 100.0 mA	0.5 mA	Operating current
	Ope. Time	0.00 ~ 10.00 s	0.01 s	Operating time

**Table 8-22 Setting items of DIRG1 element (CFP1-A43D1)**

Display name	Setting parameter	Setting		Description
		Range of setting	step	
DIRG	MT Angle	0° ~ 90° (Lead angle)	1°	Setting the maximum sensitivity angle common to DIRG1 and DIRG2
DIRG1	DIRG1 EN	OFF, ON	-	OFF: Non-use, ON: Use When this element is used, set to ON.
	Ope. Volt	2.0 ~ 100.0 V	0.1 V	Operating voltage
	Ope. Curt.	0.05 ~ 1.00 A	0.05 A	Operating current
	Ope. Time	0.00 ~ 10.00 s	0.01 s	Operating time

8.2.2. DIRG2 element

Fig. 8-13 shows the internal function blocks of DIRG2 element.

The DIRG2 element outputs a definitive signal after a preset time of the operation timer (Ope. Time) has passed, when

- a) the zero sequence current is greater than or equal to the setting value (Ope. Curt.) , AND
- b) the zero sequence voltage is greater than or equal to the setting value (Ope. Volt.), AND
- c) the phase difference between the zero-seq. current and zero-seq. voltage is within the operating area, AND
- d) second harmonic restraint on each phase is not activated

When the 2<sup>nd</sup> harmonic restraint function is not used (2f-lock EN=OFF), it does not affect the operation of the DIRG2 element.

An off-delay timer of 200 ms is added in order to prevent chattering of the output contacts. Furthermore, this element is enabled only when the setting of Use/Non-use of DIRG2 (DIRG2 EN) is set to ON. Therefore, when this element is not used, unnecessary operation can be prevented by setting to OFF. It is not necessary to adjust any other settings with regard to DIRG2 element.

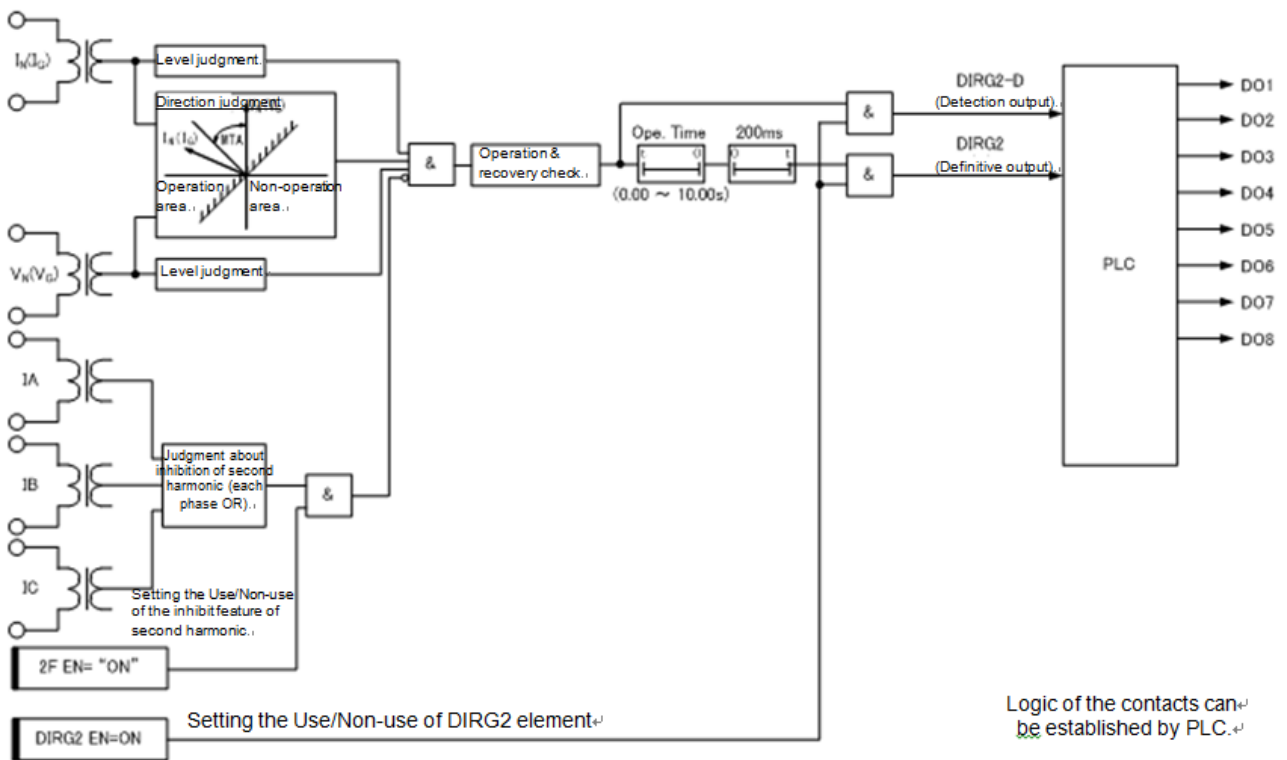

Fig. 8-13 Internal function block diagram of DIRG2 element

**Table 8-23 Setting items of DIRG2 element (CFP1-A42D1)**

Display name	Setting parameter	Setting		Description
		Range of setting	step	
DIRG	MT Angle	0° ~ 90° (Lead angle)	1°	Setting the maximum sensitivity angle common to DIRG1 and DIRG2
DIRG2	DIRG2 EN	OFF, ON	-	OFF: Non-use, ON: Use When this element is used, set to ON.
	Ope. Volt	2.0 ~ 100.0 V	0.1 V	Operating voltage
	Ope. Curt.	1.0 ~ 100.0 mA	0.5 mA	Operating current
	Ope. Time	0.00 ~ 10.00 s	0.01 s	Operating time
	2f-lock EN	OFF, ON	-	OFF: Non-use, ON: Use When the 2 <sup>nd</sup> harmonic restraint function is used, set to ON.

**Table 8-24 Setting items of DIRG2 element (CFP1-A43D1)**

Display name	Setting parameter	Setting		Description
		Range of setting	step	
DIRG	MT Angle	0° ~ 90° (Lead angle)	1°	Setting the maximum sensitivity angle common to DIRG1 and DIRG2
DIRG2	DIRG2 EN	OFF, ON	-	OFF: Non-use, ON: Use When this element is used, set to ON.
	Ope. Volt	2.0 ~ 100.0 V	0.1 V	Operating voltage
	Ope. Curt.	0.05 ~ 1.00 A	0.05 A	Operating current
	Ope. Time	0.00 ~ 10.00 s	0.01 s	Operating time
	2f-lock EN	OFF, ON	-	OFF: Non-use, ON: Use When the 2 <sup>nd</sup> harmonic restraint function is used, set to ON.

## 9. Standard (Technical data)

**Compliance standards:** Standard of the Japanese Electrotechnical Committee (JEC)

JEC2500 (2010) Protection relays for electric power systems

JEC2501 (2010) Electromagnetic compatibility tests for protection relays

JEC2502 (2010) Analog to digital converter dedicated to numerical relays

JEC2512 (2002) Directional earth fault relays

JEC2518 (2015) Digital type overcurrent relays

### Guaranteed performance

Common conditions	Frequency: Rated frequency Control power supply voltage: Rated voltage Ambient temperature: 20°C Relative humidity: 30 to 80 % on daily average	Unless otherwise indicated, the common conditions shall be as described in the left column.
-------------------	--	---

### 9.1. Relay characteristic data

Item	Test condition		Standard
Operating value	Overcurrent element (50/51)	Current setting	Setting $\pm 5\%$
	Directional ground fault element (67G)	Voltage setting	Setting $\pm 5\%$
		Current setting (a) Ope.Curt. < 10.0mA (b) 10.0mA $\leq$ Ope.Curt.	(a) Setting $\pm 10\%$ (b) Setting $\pm 5\%$
Resetting value	Overcurrent element (50/51)	Current setting	Current operating value $\times 95\%$ or more
	Directional ground fault element (67G)	Current setting	Current operating value $\times 95\%$ or more
Overshoot time characteristics	Instantaneous overcurrent element (50)	Setting : Current setting = Minimum Operating time = Maximum Current input: Current = 0 $\rightarrow$ Current setting $\times 1000\%$ Applied time: Theoretical operating time $\times 90\%$	The relay shall not operate.
	DT or IDMT overcurrent element (51)	Setting : Current setting = Minimum Operating time multiplier = 10.00 Ope. Chr. = DT01, EI01 Current input: Current = 0 $\rightarrow$ Current setting $\times 1000\%$ Applied time: Theoretical operating time $\times 90\%$	The relay shall not operate.
Phase characteristics	Directional ground fault element (67G)	Setting : Voltage setting = Minimum Current setting (a) Ope.Curt. < 10.0mA (b) 10.0mA $\leq$ Ope.Curt. Voltage input: Rated voltage Rated voltage $\times 30\%$ Current input: Current setting $\times 200\%$ Current setting $\times 1000\%$ Current setting $\times 4000\%$	(a) Setting $\pm 10\%$ (b) Setting $\pm 5\%$

Item	Test condition	Standard	
Operating time	Overcurrent element (50): 1st stage	Setting : Current setting = Minimum (a) Ope.Time : 0.00 s Input: Current = 0 → Current setting value × 200% (b) Ope.Time : 0.01s ≤ Ope.Time < 1.00s Input: Current = 0 → Current setting value × 300% (c) Ope.Time : 1.00s ≤ Ope.Time ≤ 10.00s Input: Current = 0 → Current setting value × 300%	(a) Within 30 ms (b) Ope.time setting ± 50 ms (c) Ope.time setting ± 5%
	Overcurrent element (50): 2nd stage, 3rd stage	Setting : Current setting = Minimum (a) Ope.Time : 0.00 s Input: Current = 0 → Current setting value × 200% (b) Ope.Time : 0.01s ≤ Ope.Time < 1.00s Input: Current = 0 → Current setting value × 300% (c) Ope.Time : 1.00s ≤ Ope.Time ≤ 10.00s Input: Current = 0 → Current setting value × 300%	(a) Within 40 ms (b) Ope.time setting ± 50 ms (c) Ope.time setting ± 5%
	DT or IDMT overcurrent element (51)	Setting value: Current setting = Minimum ▪ Except for DT01 Input: Current = (a) 0 → Ope.Curt.x300% (b) 0 → Ope.Curt.x500% (c) 0 → Ope.Curt.x1000% ▪ DT01 (d) Ope.TM < 1.00 Input: Current = 0 → Ope.Curt.x300%  (e) 1.00 ≤ Ope.TM ≤ 10.00 Input: Current = 0 → Ope.Curt.x300%	▪ Except for DT01 (a) Ope.time setting ± 12% or Ope.time setting ± 100 ms (b) Ope.time setting ± 7% or Ope.time setting ± 100 ms (c) Ope.time setting ± 5% or Ope.time setting ± 100 ms ▪ DT01 (d) Ope.time setting ± 50 ms (e) Ope.time setting ± 5%
	Directional ground fault element (67G)	Setting : Voltage setting = Minimum Current setting = Minimum Maximum sensitivity angle = 0° Input: Current = 0 → Ope.Curt. × 150% 0 → Ope.Curt. × 300% 0 → Ope.Curt. × 500% 0 → Ope.Curt. × 1000% 0 → Ope.Curt. × 2000% 0 → Ope.Curt. × 4000% Voltage = Rated voltage Rated voltage × 30% Phase difference between voltage and current = 0° (a) Ope.Time : 0.00 s (b) Ope.Time : 0.01s ≤ Ope.Time < 1.00s (c) Ope.Time : 1.00s ≤ Ope.Time ≤ 10.00s	(a) Within 50 ms (b) Ope.time setting ± 50 ms (c) Ope.time setting ± 5%
Reset time	Instantaneous overcurrent element (50)	Setting : Current setting = Minimum Input: Current = Current setting × 300% → 0	200 ms ± 25 ms
	DT or IDMT overcurrent element (51)	Setting : Current setting = Minimum (a) Rst. Chr. = DT (b) Rst. Chr. = IDMT (c) Rst. Chr. = INST Input: Current setting × 300% → 0	(a) 200 ms ± 25 ms (b) 200 ms ± 25 ms (c) Within 50 ms

Item	Test condition		Standard
Reset time	Directional ground fault element (67G)	Setting : Voltage setting = Minimum Current setting = Minimum Maximum sensitivity angle = 0° Input: Current = Ope.Curt. × 1000% → 0 Ope.Curt. × 2000% → 0 Voltage = Rated voltage Rated voltage × 30% Phase difference between voltage and current = 0°	200 ms ± 25 ms
Temperature characteristics	Overcurrent element (50): 1st stage	Setting : Current setting = Minimum Ope. Time. = 0.00s  (a) 0, 40 °C (b) -10, 50 °C	The error relates to the operating value & time at ambient temperature of 20 °C.  (a) Ope.value at 20°C ± 5% Within 30 ms when inputting 200% of current setting  (b) Ope.value at 20°C ± 10% Within 30 ms when inputting 200% of current setting
	Overcurrent element (50): 2nd stage, 3rd stage	Setting : Current setting = Minimum Ope. Time. = 0.00s  (a) 0, 40 °C (b) -10, 50 °C	The error relates to the operating value & time at ambient temperature of 20 °C.  (a) Ope.value at 20°C ± 5% Within 40 ms when inputting 200% of current setting  (b) Ope.value at 20°C ± 10% Within 40 ms when inputting 200% of current setting
	DT or IDMT overcurrent element (51)	Ope. value Setting : Current setting = Minimum Operating time multiplier = Minimum Ope. Chr. = DT01 (a) 0, 40°C (b) -10, 50°C  Ope. time Setting : Current setting = Minimum Operating time multiplier = 10.00 Ope. Chr. = EI01 (a) 0, 40°C (b) -10, 50°C	The error relates to the operating value & time at ambient temperature of 20°C.  Ope. value (a) Ope.value at 20°C ± 5% (b) Ope.value at 20°C ± 10%  Ope. time (a) Ope. time at 20°C ± 10% (b) Ope. time at 20°C ± 20%

Item	Test condition		Standard
Temperature characteristics	Directional ground fault element (67G)	<p>Ope. value Setting : Voltage setting = Minimum Current setting = Minimum Maximum sensitivity angle = 0° (a) 0, 40°C (b) -10, 50°C</p> <p>Phase characteristics Setting : Voltage setting = Minimum Current setting = Minimum Maximum sensitivity angle = 0° Input: Current = 0 → Ope.Curt. × 200% 0 → Ope.Curt. × 1000% 0 → Ope.Curt. × 4000% Voltage = Rated voltage (a) 0, 40°C (b) -10, 50°C</p>	<p>The error relates to the operating value &amp; phase characteristic at ambient temperature of 20°C.</p> <p>Ope. value (a) Ope.value at 20°C ± 5% (b) Ope.value at 20°C ± 10%</p> <p>Phase characteristics (a) Ope. time at 20°C ± 5% (b) Ope. time at 20°C ± 10%</p>
Power supply voltage characteristics	All elements	Variation range of control power supply = DC 88 V, DC 300 V, AC 85 V, AC 264 V	Within ± 5% of the measured value at rated voltage
Distorted wave characteristics	Overcurrent element (50/51)	<p>Third harmonic content: 30% of distortion factor Fifth harmonic content: 30% of distortion factor Seventh harmonic content: 30% of distortion factor</p> <p>Instantaneous overcurrent element (50) Setting : Current setting = Minimum Operating time = Minimum</p> <p>DT or IDMT overcurrent element (51) Setting : Current setting = Minimum Operating time multiplier = Minimum Ope. Chr. = DT01</p>	Ope. value at 1f ± 10%
	Directional ground fault element (67G)	<p>Third harmonic content: 30% of current distortion factor and 90% of voltage distortion factor Fifth harmonic content: 30% of current distortion factor and 90% of voltage distortion factor Seventh harmonic content: 30% of current distortion factor and 90% of voltage distortion factor</p> <p>Setting : Voltage setting = Minimum Current setting = Minimum Maximum sensitivity angle = 0°</p>	<p>Current Ope. value at 1f ± 15% Voltage Ope. value at 1f ± 10% Phase Ope. value at 1f ± 10°</p>

Item	Test condition	Standard	
Frequency characteristics	Overcurrent element (50): 1st stage	Frequency: Rated frequency $\pm 5\%$ Setting : Current setting = Minimum Ope. Time. = 0.00s	Ope.value at rated freq. $\pm 5\%$  Within 30 ms when inputting 200% of current setting
	Overcurrent element (50): 2nd stage, 3rd stage	Frequency: Rated frequency $\pm 5\%$ Setting : Current setting = Minimum Ope. Time. = 0.00s	Ope.value at rated freq. $\pm 5\%$  Within 40 ms when inputting 200% of current setting
	DT or IDMT overcurrent element (51)	Frequency: Rated frequency $\pm 5\%$  Ope. value Setting : Current setting = Minimum Operating time multiplier = Minimum Ope. Chr. = DT01  Ope. time Setting : Current setting = Minimum Operating time multiplier = 10.00 Ope. Chr. = EI01 (a) Input: Current = 0 $\rightarrow$ Ope.Curt.x300% (b) Input: Current = 0 $\rightarrow$ Ope.Curt.x500% (c) Input: Current = 0 $\rightarrow$ Ope.Curt.x1000%	Ope.value at rated freq. $\pm 5\%$    Ope. time: (a)Ope. time at rated freq. $\pm 12\%$ (b)Ope. time at rated freq. $\pm 7\%$ (c)Ope. time at rated freq. $\pm 5\%$
	Directional ground fault element (67G)	Frequency: Rated frequency $\pm 5\%$  Ope. value Setting : Voltage setting = Minimum Current setting = Minimum Maximum sensitivity angle = $0^\circ$  Phase characteristics Setting : Voltage setting = Minimum Current setting = Minimum Maximum sensitivity angle = $0^\circ$ Input: Current = 0 $\rightarrow$ Ope.Curt. $\times$ 200% 0 $\rightarrow$ Ope.Curt. $\times$ 1000% 0 $\rightarrow$ Ope.Curt. $\times$ 4000% Voltage = Rated voltage	Current Ope.value at rated freq. $\pm 5\%$ Voltage Ope.value at rated freq. $\pm 5\%$  Phase characteristics Ope.value at rated freq. $\pm 5\%$
Superposition of DC	Overcurrent element (50/51)	Superimpose DC current with damping time constant of $\tau$ Input current: $I_A = 0 \rightarrow I_{ac} + I_{dc}$ $I_{ac} = \text{Ope. value} \times 90\%$ $I_{dc} = \sqrt{2} \times I_{ac} \times \{\exp(-t/\tau) - \cos\omega t\}$ $\tau = 15, 83, 150 \text{ ms}$  Instantaneous overcurrent element (50) Setting : Current setting = Minimum Ope. Time. = Minimum  DT or IDMT overcurrent element (51) Setting : Current setting = Minimum Operating time multiplier = Minimum Ope. Chr. = DT01	The relay shall not operate.

Item	Test condition		Standard
Maximum current in guaranteed operating range	Overcurrent element (50/51)	Input current : 200A, for 300 ms, twice, at intervals of 1 min  Instantaneous overcurrent element (50) Setting : Current setting = Maximum Ope. Time. = Minimum  DT or IDMT overcurrent element (51) Setting : Current setting = Maximum Operating time multiplier = Minimum Ope. Chr. = DT01	The relay shall operate.
Overload characteristics	Directional ground fault element (67G)	Setting : Voltage setting = Minimum Current setting = Minimum Maximum sensitivity angle = 0° Input current : Ope. Curt. × 4000% Input voltage : Rated voltage × 150%	The relay shall operate and reset for sure. (No incorrect operation, no incorrect non-operation)
Creeping	Directional ground fault element (67G)	Open / short current circuit while applying voltage. Setting : Voltage setting = Minimum Current setting = Minimum Maximum sensitivity angle = 0° Input voltage : Rated voltage × 150% Input current : Open or Short	The relay shall not operate.
Overload capability	Directional ground fault element (67G)	Setting : Voltage setting = Minimum Current setting = Minimum Maximum sensitivity angle = 0° Input : For 1 s, twice, at intervals of 1 min Current : 0 → Rated current × 4000% Voltage : Rated voltage × 150%	The relay shall operate.

## 9.2. General specification data

Item	Test condition		Standard
Contact capacity	Contact for tripping	Closed circuit capacity	DC 110 V : 15 A DC 220 V : 10 A 0.5s L/R = 0
		Open-circuit capacity	DC 110 V : 0.3 A DC 220 V : 0.15 A L/R = 40 ms
	Contact for annunciator		Open- / Closed circuit capacity : 500VA (cosφ = 0.4), 60W (L/R = 7ms)  Max. current : 5 A Max. voltage : AC 380 V DC 125 V
Overload capacity	Current circuit	Rated current × 40 times, for 2 s, twice, at intervals of 1 min	No malfunction, no unnecessary operation, no abnormal indication, and etc.
	Voltage circuit	Rated voltage × 1.15 times, 3 hr Positive-phase-sequence voltage : Rated voltage × 2.17 times, for 10 s, once	
		Zero-phase-sequence voltage : Rated voltage × 1.5 times, for 5 s, once	
Insulation resistance	DC500 V meg-ohm-meter is used. (1) Between collective electric circuit and ground (However, the serial communication circuit is excluded.) (2) Between mutual circuits, between contact poles (However, the serial communication circuit is excluded.)		(1) 10 MΩ or more (2) 5 MΩ or more
Withstand voltage at commercial frequency	(1) Between collective electric circuit and ground : AC2000 V, 1 min (2) Between mutual circuits, between contact poles : AC2000 V, 1 min (However, the serial communication circuit is excluded.) (3) Between contact terminals (between poles) : AC1000 V, 1 min		No malfunction, no unnecessary operation, no abnormal indication, and etc.
Withstand voltage against lightning impulse	Standard shock voltage waveform (1.2/50 μs)  Application to each of positive and negative pole for 3 times	4.5 kV	No malfunction, no unnecessary operation, no abnormal indication, and etc.
		3 kV	

Item	Test condition	Standard
Trouble of control power supply	<ul style="list-style-type: none"> <li>▪ Turning on/off control power supply</li> <li>▪ Instantaneous interruption of control power supply</li> <li>▪ Slow variation of control power supply</li> </ul>	No malfunction, no unnecessary operation, no abnormal indication, and etc.
Immunity against electrostatic discharge	8 kV: Contact discharge 15 kV: Aerial discharge  10 times of each of positive and negative pole at intervals of more than 1s	No malfunction, no unnecessary operation, no abnormal indication, and etc.
Immunity against commercial frequency	Applied point: Between line and ground Test voltage: 300 V, Test time: 10 s  Applied point: Between lines Test voltage: 150 V, Test time: 10 s	No malfunction, no unnecessary operation, no abnormal indication, and etc.
Immunity against damped oscillatory wave	<ul style="list-style-type: none"> <li>▪ Peak value of 1st wave: 2.5 kV</li> <li>▪ Vibration frequency: 1 MHz <math>\pm</math> 10%</li> <li>▪ Damping time to 1/2: 3 ~ 6 cycles</li> <li>▪ Frequency of repetition: 6 ~ 10 times/ 1 cycle of commercial frequency (asynchronous)</li> <li>▪ Output impedance of test circuit: 200 <math>\Omega</math> <math>\pm</math> 10%</li> </ul> Applied point: <ul style="list-style-type: none"> <li>▪ Between collective transformer circuit and ground</li> <li>▪ Between collective control power supply circuit and ground</li> <li>▪ Between terminals of control power supply circuit</li> </ul>	No malfunction, no unnecessary operation, no abnormal indication, and etc.
Electric fast transient/Burst immunity	Applied voltage: $\pm$ 2.0 kV Repetition frequency: 5.0 kHz Port for applied: Between collective control power supply circuit and ground	No malfunction, no unnecessary operation, no abnormal indication, and etc.
	Applied voltage: $\pm$ 1.0 kV Repetition frequency: 5.0 kHz Port for applied: <ul style="list-style-type: none"> <li>▪ Between collective transformer circuit for measuring instruments and ground</li> <li>▪ Between collective binary input/output (DI/DO) circuit and ground</li> </ul>	
Immunity to square wave impulse	Applied voltage: 1.0 kV $\pm$ 10% Test time : 2s Each of positive and negative pole Output impedance : 50 $\Omega$ Pulse duration : 100 ns $\pm$ 30% Pulse rise time : 1 ns or less  Port for applied: <ul style="list-style-type: none"> <li>▪ Between collective transformer circuit and ground</li> <li>▪ Between collective control power supply circuit and ground</li> <li>▪ Between collective binary input/output (DI/DO) circuit and ground</li> <li>▪ Between terminals of control power supply circuit</li> </ul>	No malfunction, no unnecessary operation, no abnormal indication, and etc.

Item	Test condition	Standard
Surge immunity	<p>Applied time : 1.2/50 <math>\mu</math>s at open circuit condition 8/20 <math>\mu</math>s at short circuit condition Effective output impedance : 2 <math>\Omega</math> 5 times of each of positive and negative pole at intervals 1min</p> <p>Port for applied and applied voltage:</p> <ul style="list-style-type: none"> <li>▪ Between control power supply terminals: Applied voltage : 0.5, 1 kV (0 <math>\Omega</math>, 18 <math>\mu</math>F, 1.5 mH)</li> <li>▪ Between collective control power supply and ground: Applied voltage : 0.5, 1, 2 kV (10 <math>\Omega</math>, 9 <math>\mu</math>F, 1.5 mH)</li> <li>▪ Between binary input/output circuit terminals: Applied voltage : 0.5, 1 kV (40 <math>\Omega</math>, 0.5 <math>\mu</math>F, 20 mH)</li> <li>▪ Between collective binary input/output circuit and ground: Applied voltage : 0.5, 1, 2 kV (40 <math>\Omega</math>, 0.5 <math>\mu</math>F, 20 mH)</li> <li>▪ Between transformer circuits for measuring instruments: Applied voltage : 0.5, 1 kV (40 <math>\Omega</math>, 0.5 <math>\mu</math>F, 20 mH)</li> <li>▪ Between collective transformer circuit for measuring instruments and ground: Applied voltage : 0.5, 1, 2 kV (40 <math>\Omega</math>, 0.5 <math>\mu</math>F, 20mH)</li> </ul>	No malfunction, no unnecessary operation, no abnormal indication, and etc.
Commercial frequency magnetic field immunity	<p>Magnetic field intensity : 30 A/m, for 60 s (continuous), at once 300 A/m, for 2s, three times at intervals of 1 min</p> <p>* Setting value of the I0 circuit for ZCT input shall be 5 mA or more.</p>	No malfunction, no unnecessary operation, no abnormal indication, and etc.
Immunity to conducted disturbances, induced by radio- frequency fields	<p>Voltage level : 10 V Amplitude modulation : 1 kHz, <math>\pm</math>80% Frequency range : (a) Sweep test : 150 kHz ~ 80 MHz (b) Spot test : 27, 68 MHz</p> <p>Test time : (a) Sweep test : 0.5 s or more at each step of frequency (b) Spot test : 10 s or more at each frequency</p> <p>Port for applied :</p> <ul style="list-style-type: none"> <li>▪ Between collective control power supply and ground</li> <li>▪ Between collective binary input/output circuit and ground</li> <li>▪ Between collective transformer circuit for measuring instruments and ground</li> </ul>	No malfunction, no unnecessary operation, no abnormal indication, and etc.
Radiated, radio-frequency, electromagnetic field immunity	<p>Voltage level : 10 V/m Amplitude modulation : 1 kHz, <math>\pm</math>80% Frequency range : (a) Sweep test : 80 MHz ~ 1.0 GHz, 1.4 GHz ~ 2.7 GHz (b) Spot test : 80, 160, 380, 450, 900, 1850, 2150 MHz</p> <p>Test time : (a) Sweep test : 0.5 s or more at each step of frequency (b) Spot test : 10 s or more at each frequency</p> <p>Number of test time : Twice at each frequency for each direction of back and forth, right and left (4 directions) ; In total, 8 times at each frequency</p>	No malfunction, no unnecessary operation, no abnormal indication, and etc.

Item	Test condition								Standard
Vibration	Frequency (Hz)	Amplitude (mm)			Time (s)	Acceleration (m/s <sup>2</sup> )			No malfunction, no unnecessary operation, no abnormal indication, and etc.
		Back and forth	Right and left	Up and down		Each direction	Back and forth	Right and left	
	10	5	2.5	30	10	5			
16.7	0.4		600	2					
Shock	<ul style="list-style-type: none"> <li>▪ Shock acceleration : 300 m/s<sup>2</sup></li> <li>▪ Duration of pulse : 11 ms</li> <li>▪ Direction of pulses : Respective 3 directions in back and forth, right and left, up and down (6 directions)</li> <li>▪ Number of pulses : 3 times for 6 directions (In total : 18 times)</li> </ul>								No malfunction, no unnecessary operation, no abnormal indication, and etc.
Load	<ul style="list-style-type: none"> <li>(1) Current circuit</li> <li>(2) Voltage circuit</li> <li>(3) Control power supply</li> </ul>								<ul style="list-style-type: none"> <li>(1) At the rating of 5 A: 0.6 VA or less</li> <li style="padding-left: 20px;">At the rating of 1 A: 0.1 VA or less</li> <li>(2) 0.1 VA or less</li> <li>(3) 10 W or less</li> </ul>
Mass	<ul style="list-style-type: none"> <li>(1) Subunit</li> <li>(2) Subunit and outer case</li> </ul>								<ul style="list-style-type: none"> <li>(1) About 2.3 kg</li> <li>(2) About 3.7 kg</li> </ul>

## 10. Test

Although all necessary functional tests are implemented for this relay before shipment from the factory, it is recommendable to perform the tests with reference to the following items, before use.

### 10.1. Visual inspection

Perform the visual inspection check with reference to the following items.

Inspection item	Contents of inspection
Unit (working part)	(1) No deformation (2) Operational check of the operation key switches (3) Neither discoloration nor deformation of the front name plate (4) No damage at the terminal connectors
Case	No damage including the terminal connectors
Others	No foreign substances, such as dust, iron pieces, etc.

## 10.2. Characteristic test

### 10.2.1. Notes related to the tests

#### (1) Recommended test condition

Regarding the ambient conditions, following conditions shall be complied with, as far as possible. If the test is performed at the condition which is significantly different from the next condition, the correct test results may not be obtained.

- Ambient temperature:  $20^{\circ}\text{C} \pm 10^{\circ}\text{C}$
- Rated frequency:  $\pm 1\%$
- Waveform (AC): Distortion factor 2% or less
- Control voltage: Rated voltage  $\pm 2\%$

#### (2) Functional control points

Refer to Chapter 9.

The functional control point (standard point) of each relay's element shall be checked by the relay alone. Therefore, when the combined test with external devices such as CT, ZCT, etc. is performed, it shall be considered the error factor of external devices.

Furthermore, if user-defined control point is specified (e.g. accuracy of relay characteristic is controlled at service conditions), execute the test at the manufacturer-defined control point (mentioned in Section 9.1) before in-service operation and then check accuracy of the relay.

After that, execute the test at the user-defined control point, and set this data to the subsequent standards.

#### (3) Setting change

Refer to 5.3.4.1 for the setting change.

#### (4) Judgment of operation

Basically, the measurement of the operating value, operating time, etc. shall be done by open/close of the output relay contact of each element.

10.2.2. Characteristic test

(1) Test circuit

The external connection of AC input circuit is as shown below as a reference.  
Refer to Fig. 2-3 for the terminal arrangement.

[1] Overcurrent element

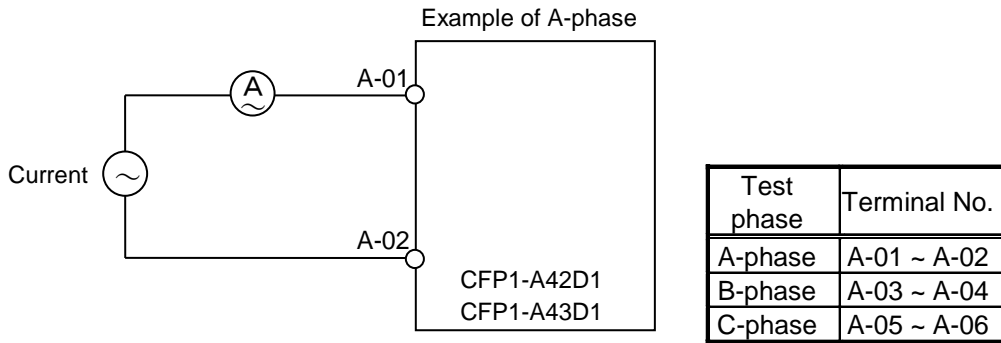

[2] Directional ground fault element

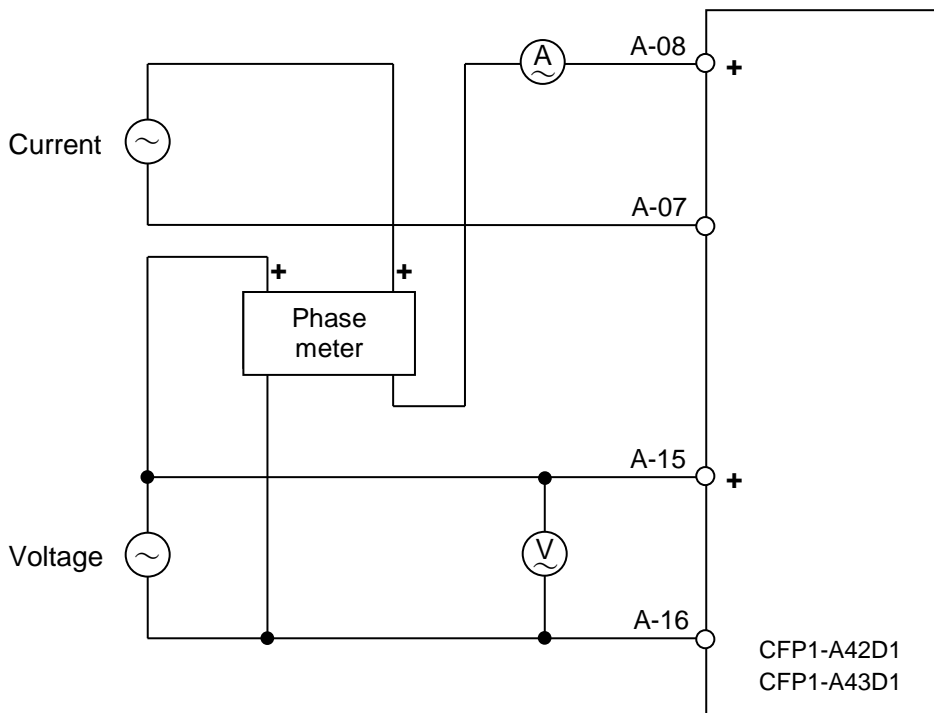

(2) Test items

[1] Test setting

Before starting test, it is recommended to use 'Test setting' function in order to lock the operation of un-tested phases and elements.

As for the method of test setting, refer to 5.3.4.3.2 in Chapter 5.

As for the list of test setting items, refer to the table shown below.

**List of test setting items**

No.	Name of items	Contents of setting	Setting
1	SV-LK	Locking of alarm function	UNLOCKED / LOCKED
2	TCNT-LK	Locking of trip counter	UNLOCKED / LOCKED

[2] Forced operation test (DO contact test)

Refer to 5.3.4.3.1 in Chapter 5.

[3] Operating value test

Refer to the "Operating value" and "Resetting value" in Chapter 9.

[4] Operating time test

Refer to the "Operating time" in Chapter 9.

[5] Resetting time test

Refer to the "Reset time" in Chapter 9.

[6] Phase characteristics test

Refer to the "Phase characteristics" in Chapter 9.

[7] LED/VFD full lighting test

Refer to 5.3.4.3.3 in Chapter 5.

# 11. Maintenance and self diagnosis

## 11.1. Maintenance

### 11.1.1. Daily inspection

It is recommended to check the following items daily;

- No dust (such as iron powder, etc) is in/on the relay case
- No abnormal noise is generated
- 'RUN' LED is lighting

### 11.1.2. Periodic inspection

It is recommended to test the following items periodically.

- Visual inspection, referring to Section 10.1.
- Characteristic test, referring to Section 10.2.

## 11.2. Self diagnosis

Monitoring of the electronic circuit as well as the incorporated power supply is performed. If any trouble is generated, fault display by LED and output by alarm DO (b contact) are executed.

### 1. Alarm indication

The relay alarm, which would be appeared at relay failure, is divided two types, minor failure and serious failure.

Minor failure ----- This alarm may appear by detecting the abnormal current or voltage input, or abnormality of the circuits which would not affect the relay's trip operation directly.

Serious failure --- This alarm may appear by detecting abnormality of the important circuits which would affect the relay's trip operation directly.

The operation of LED display and alarm DO output are shown in next table.

**Table 11-1 LED display, Alarm DO**

Status of the relay	Alarm DO	RUN LED	ALARM LED
Minor failure	OFF	ON	ON
Serious failure	ON	OFF	ON

Since the indication of 'ALARM LED' at fault detection is latched, it is necessary to press 'ESC/C' key for 3 sec or more after removing the cause of trouble.

### 2. Handling of Alarm indication

When any trouble is generated, please collect the necessary information as shown below which would be useful for finding the cause of trouble.

[1] Confirm the state of LED display and the contact of alarm DO.

Refer to Fig. 11-1, Fig. 11-2 for LED display and alarm DO.

[2] Confirm the error code in monitoring

Refer to 5.3.2.2.4 in Chapter 5 for the confirmation method of the error code,

[3] Please contact your service provider.

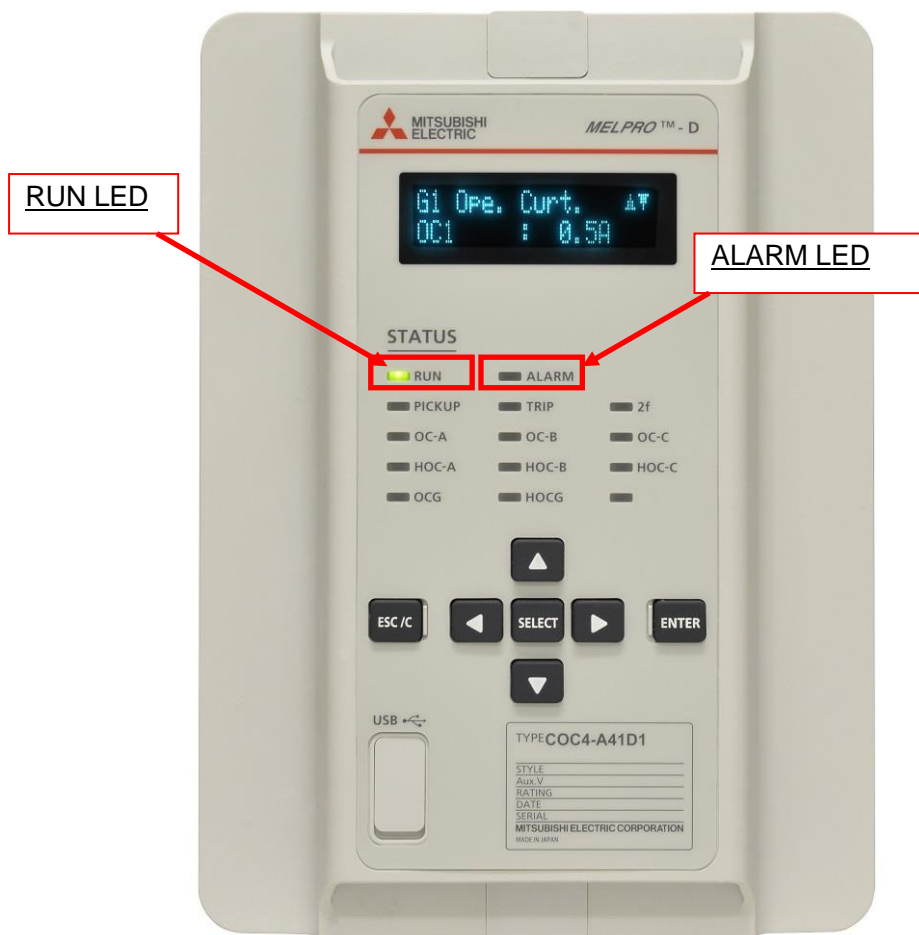

**Fig. 11-1 Position of RUN LED, ALARM LED**

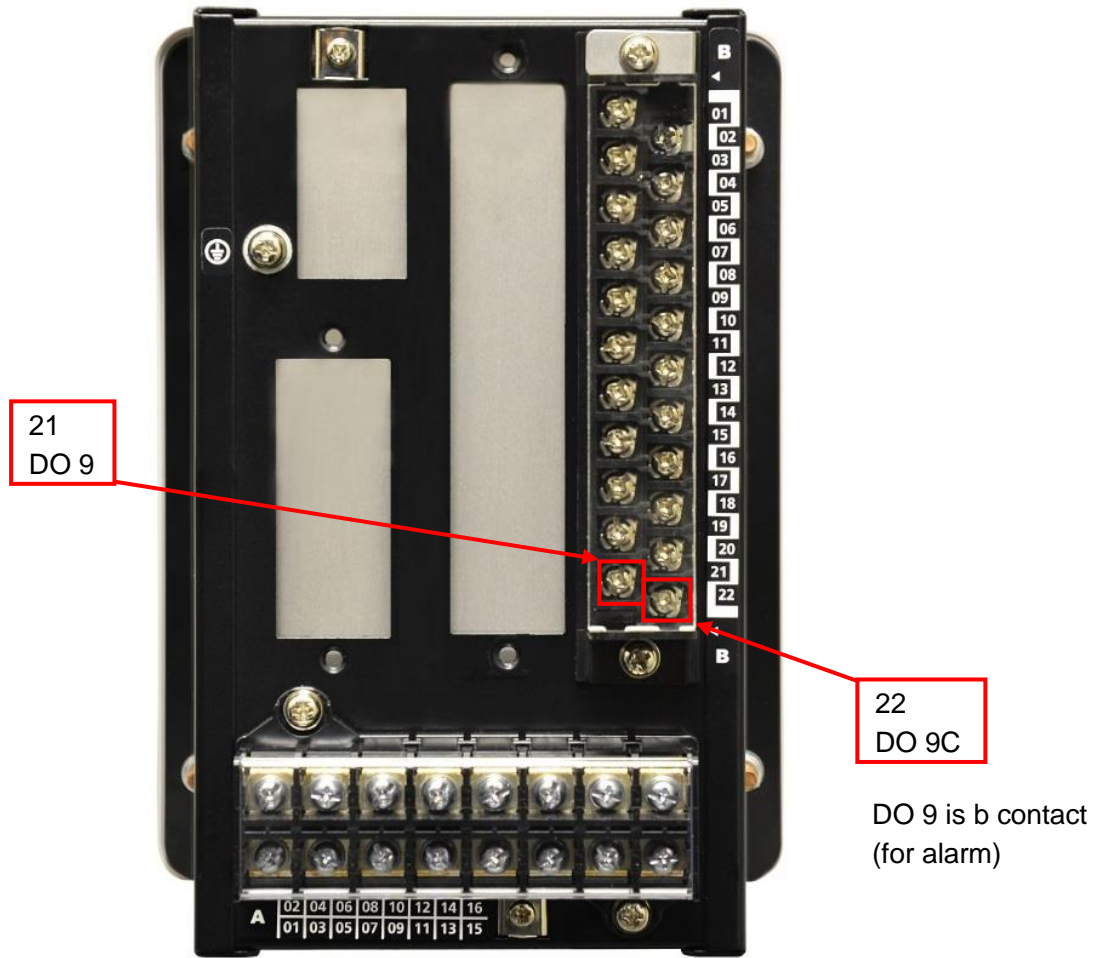

Fig. 11-2 Position of alarm DO

## 12. Default setting or configuration value

### 12.1. Setting

- CFP1-A42D1

Category	Element	Setting								
		Item name or Setting parameter		Range		Step	Default value		Please make a note about setting.	
		VFD	PC-HMI	VFD	PC-HMI		VFD	PC-HMI	Group 1 (G1)	Group 2 (G2)
OC	2F	2f-lock ratio	2f-lock ratio	10 ~ 30%		1%	10%	10%		
		1f-Min. Ope.	1f-Min. Ope.	0.4 ~ 2.5A		0.1A	0.4A	0.4A		
	OC1	OC1 EN	OC1 EN	OFF ON	Off On	—	OFF	Off		
		Ope. Curt.	OC1 Ope. Curt.	0.5 ~ 100.0A		0.1A	0.5A	0.5A		
		Ope. Time	OC1 Ope. Time	0.00 ~ 10.00s		0.01s	0.00s	0.00s		
	OC2	OC2 EN	OC2 EN	OFF ON	Off On	—	OFF	Off		
		Ope. Curt.	OC2 Ope. Curt.	0.5 ~ 100.0A		0.1A	0.5A	0.5A		
		Ope. Time	OC2 Ope. Time	0.00 ~ 10.00s		0.01s	0.00s	0.00s		
		2f-lock EN	OC2 2f-lock EN	OFF ON	Off On	—	OFF	Off		
	OC3	OC3 EN	OC3 EN	OFF ON	Off On	—	OFF	Off		
		Ope. Curt.	OC3 Ope. Curt.	0.5 ~ 100.0A		0.1A	0.5A	0.5A		
		Ope. Time	OC3 Ope. Time	0.00 ~ 10.00s		0.01s	0.00s	0.00s		
		2f-lock EN	OC3 2f-lock EN	OFF ON	Off On	—	OFF	Off		
	OC4	OC4 EN	OC4 EN	OFF ON	Off On	—	OFF	Off		
		Ope. Curt.	OC4 Ope. Curt.	0.5 ~ 100.0A		0.1A	0.5A	0.5A		
		Ope. TM	OC4 Ope. TM	0.25 ~ 50.00		0.01	10.00	10.00		
		Ope. Chr.	OC4 Ope. Chr.	NI01 VI01 EI01 LI01 LI02 DT01 NI11 EH11 EI12 NI21 VI21 LI21 NI31 VI31		—	NI01	NI01		
		Rst. Chr.	OC4 Rst. Chr.	IDMT DT INST		—	IDMT	IDMT		
		2f-lock EN	OC4 2f-lock EN	OFF ON	Off On	—	OFF	Off		
		IEC Chr. EN	OC4 IEC Chr. EN	OFF ON	Off On	—	OFF	Off		
DIRG	DIRG	MT Angle	DIRG MT Angle	0 ~ 90°LEAD		1°LEAD	0°LEAD	0°LEAD		
	DIRG1	DIRG1 EN	DIRG1 EN	OFF ON	Off On	—	OFF	Off		
		Ope. Volt.	DIRG1 Ope. Volt.	2.0 ~ 100.0V		0.1V	2.0V	2.0V		
		Ope. Curt.	DIRG1 Ope. Curt.	1.0 ~ 100.0mA		0.5mA	1.0mA	1.0mA		
		Ope. Time	DIRG1 Ope. Time	0.00 ~ 10.00s		0.01s	0.00s	0.00s		
	DIRG2	DIRG2 EN	DIRG2 EN	OFF ON	Off On	—	OFF	Off		
		Ope. Volt.	DIRG2 Ope. Volt.	2.0 ~ 100.0V		0.1V	2.0V	2.0V		
		Ope. Curt.	DIRG2 Ope. Curt.	1.0 ~ 100.0mA		0.5mA	1.0mA	1.0mA		
		Ope. Time	DIRG2 Ope. Time	0.00 ~ 10.00s		0.01s	0.00s	0.00s		
	System setting	—	Pre-Rec.	Pre-Rec. Time	100 ~ 4500ms		10ms	100ms	100ms	
—		Rec.	Max. Rec. Time	200 ~ 5000ms		10ms	200ms	200ms		
—		PASSWORD	—	UNUSE USE	—	—	UNUSE	—		
—		PASS	—	0000 ~ 9999		1	0000	—		
Trip counter	—	Initial	Initial Value	0 ~ 10000		1	0	0		
	—	Alarm	Alarm Value	1 ~ 10000		1	1	1		
Analog value display	—	AI Disp.	AI Display Style	PRIMARY SECONDARY	Primary Secondary	—	PRIMARY	Primary		
	—	PTGP	PTGP	0.10 ~ 99.00kV		0.01kV	5.00kV	5.00kV		
	—	PTGS	PTGS	100 ~ 220V		1V	100V	100V		
	—	CTP	CTP	5 ~ 30000A		1A	5A	5A		
	—	CTS	CTS	1A 5A		—	5A	5A		
	—	CTGP	CTGP	0.1 ~ 100.0A		0.1A	0.2A	0.2A		
DO contact test setting	—	—	One-Shot Time	—		1s	—	1s		
	—	—	—	1 ~ 20s		—	—	—		

• CFP1-A43D1

Category	Element	Setting								
		Item name or Setting parameter		Range		Step	Default value		Please make a note about setting.	
		VFD	PC-HMI	VFD	PC-HMI		VFD	PC-HMI	Group 1 (G1)	Group 2 (G2)
OC	2F	2f-lock ratio	2f-lock ratio	10 ~ 30%		1%	10%	10%		
		1f-Min. Ope.	1f-Min. Ope.	0.4 ~ 2.5A		0.1A	0.4A	0.4A		
	OC1	OC1 EN	OC1 EN	OFF ON	Off On	—	OFF	Off		
		Ope. Curt.	OC1 Ope. Curt.	0.5 ~ 100.0A		0.1A	0.5A	0.5A		
		Ope. Time	OC1 Ope. Time	0.00 ~ 10.00s		0.01s	0.00s	0.00s		
	OC2	OC2 EN	OC2 EN	OFF ON	Off On	—	OFF	Off		
		Ope. Curt.	OC2 Ope. Curt.	0.5 ~ 100.0A		0.1A	0.5A	0.5A		
		Ope. Time	OC2 Ope. Time	0.00 ~ 10.00s		0.01s	0.00s	0.00s		
		2f-lock EN	OC2 2f-lock EN	OFF ON	Off On	—	OFF	Off		
	OC3	OC3 EN	OC3 EN	OFF ON	Off On	—	OFF	Off		
		Ope. Curt.	OC3 Ope. Curt.	0.5 ~ 100.0A		0.1A	0.5A	0.5A		
		Ope. Time	OC3 Ope. Time	0.00 ~ 10.00s		0.01s	0.00s	0.00s		
		2f-lock EN	OC3 2f-lock EN	OFF ON	Off On	—	OFF	Off		
	OC4	OC4 EN	OC4 EN	OFF ON	Off On	—	OFF	Off		
		Ope. Curt.	OC4 Ope. Curt.	0.5 ~ 100.0A		0.1A	0.5A	0.5A		
		Ope. TM	OC4 Ope. TM	0.25 ~ 50.00		0.01	10.00	10.00		
Ope. Chr.		OC4 Ope. Chr.	NI01 VI01 EI01 LI01 LI02 DT01 NI11 EI11 EI12 NI21 VI21 LI21 NI31 VI31		—	NI01	NI01			
Rst. Chr.		OC4 Rst. Chr.	IDMT DT INST		—	IDMT	IDMT			
2f-lock EN		OC4 2f-lock EN	OFF ON	Off On	—	OFF	Off			
	IEC Chr. EN	OC4 IEC Chr. EN	OFF ON	Off On	—	OFF	Off			
DIRG	DIRG	MT Angle	DIRG MT Angle	0 ~ 90°LEAD		1°LEAD	0°LEAD	0°LEAD		
	DIRG1	DIRG1 EN	DIRG1 EN	OFF ON	Off On	—	OFF	Off		
		Ope. Volt.	DIRG1 Ope. Volt.	2.0 ~ 100.0V		0.1V	2.0V	2.0V		
		Ope. Curt.	DIRG1 Ope. Curt.	0.05 ~ 1.0A		0.05A	0.05A	0.05A		
		Ope. Time	DIRG1 Ope. Time	0.00 ~ 10.00s		0.01s	0.00s	0.00s		
	DIRG2	DIRG2 EN	DIRG2 EN	OFF ON	Off On	—	OFF	Off		
		Ope. Volt.	DIRG2 Ope. Volt.	2.0 ~ 100.0V		0.1V	2.0V	2.0V		
		Ope. Curt.	DIRG2 Ope. Curt.	0.05 ~ 1.0A		0.05A	0.05A	0.05A		
		Ope. Time	DIRG2 Ope. Time	0.00 ~ 10.00s		0.01s	0.00s	0.00s		
		2f-lock EN	DIRG2 2f-lock EN	OFF ON	Off On	—	OFF	Off		
System setting	—	Pre-Rec.	Pre-Rec. Time	100 ~ 4500ms		10ms	100ms	100ms		
	—	Rec.	Max Rec. Time	200 ~ 5000ms		10ms	200ms	200ms		
	—	PASSWORD	—	UNUSE USE	—	—	UNUSE	—		
	—	PASS	—	0000 ~ 9999		1	0000	—		
Trip counter	—	Initial	Initial Value	0 ~ 10000		1	0	0		
	—	Alarm	Alarm Value	1 ~ 10000		1	1	1		
Analog value display	—	AI Disp.	AI Display Style	PRIMARY SECONDARY	Primary Secondary	—	PRIMARY	Primary		
	—	PTGP	PTGP	0.10 ~ 99.00kV		0.01kV	5.00kV	5.00kV		
	—	PTGS	PTGS	100 ~ 220V		1V	100V	100V		
	—	CTP	CTP	5 ~ 30000A		1A	5A	5A		
	—	CTS	CTS	1A 5A		—	5A	5A		
	—	CTGP	CTGP	5 ~ 30000A		1A	5A	5A		
	—	CTGS	CTGS	1A 5A		—	1A	1A		
DO contact test setting	—	—	One-Shot Time	—		1 ~ 20s	1s	—	1s	

## 12.2. Output contacts

- CFP1-A42D1

	Item name (PC-HMI)	Default value (PLC signal)	Please make a note about setting.
Contacts for tripping (DO)	DO1	ALLEL-O	
	DO2	ALLEL-O	
	DO3	ALLEL-O	
	DO4	ALLEL-O	
Contacts for annunciator (DO)	DO5	DIRG-O	
	DO6	DIRG-O	
	DO7	HOC-3_O/	
	DO8	OC4-3_O/	

- CFP1-A43D1

	Item name (PC-HMI)	Default value (PLC signal)	Please make a note about setting.
Contacts for tripping (DO)	DO1	ALLEL-O	
	DO2	ALLEL-O	
	DO3	ALLEL-O	
	DO4	ALLEL-O	
Contacts for annunciator (DO)	DO5	DIRG-O	
	DO6	DIRG-O	
	DO7	HOC-3_O/	
	DO8	OC4-3_O/	

# **mitsubishi electric corporation**

HEAD OFFICE : 7-3 MARUNOUCHI 2-CHOME, CHIYODA-KU TOKYO, 100-8310, JAPAN

**First edition: Oct. 2018**