

Specifications

ME96SSEB-MB

Model name		ME96SSEB-MB	
Phase wire system		3-phase 4-wire, 3-phase 3-wire (3CT, 2CT), 1-phase 3-wire, 1-phase 2-wire (common use)	
Rating	Current	5 A AC, 1 A AC (common use)	
	Voltage	3-phase 4-wire: max 277/480 V AC 3-phase 3-wire: (DELTA) max 220 V AC, (STAR) max 440 V AC 1-phase 3-wire: max 220/440 V AC 1-phase 2-wire: (DELTA) max 220 V AC, (STAR) max 440 V AC	
	Frequency	50/60 Hz (common use)	
Item		Measuring Item	Class
Measuring element	Current (A)	A1, A2, A3, AN, A _{AVG}	±0.5%
	Current demand (DA)	DA1, DA2, DA3, DAN, DA _{AVG}	
	Voltage (V)	V12, V23, V31, V _{AVG} (L-L), V1N, V2N, V3N, V _{AVG} (L-N)	
	Active power (W)	W1, W2, W3, ΣW	
	Reactive power (var)	var1, var2, var3, Σvar	
	Apparent power (VA)	VA1, VA2, VA3, ΣVA	
	Power factor (PF)	PF1, PF2, PF3, ΣPF	±0.5%
	Frequency (Hz)	Hz	±0.2%
	Active energy (Wh)	Imported, Exported	Class 0.5S (IEC62053-22)
	Reactive energy (varh)	Imported lag, Imported lead, Exported lag, Exported lead	Class 1S (IEC62053-24)
	Apparent energy (VAh)	Imported + Exported	±2.0%
	Harmonic current (HI)	Total	±2.0%
	Harmonic voltage (HV)	Total	
Operating time (h)	Operating time 1, Operating time 2	(Reference)	
Measuring method	Instantaneous value	A, V: RMS value calculation; W, var, VA, Wh, varh, VAh: Digital multiplication; PF: Power ratio calculation; Hz: Zero-cross; HI, HV: FFT	
	Demand value	DA: Thermal type calculation	
Display	Display type		LCD with LED backlight
	The number of display digits or The number of segments	Digital section	First to Third line display: 4 digits, Fourth line display: 6 digits
			A, DA, V, W, var, VA, PF: 4 digits; Hz: 3 digits; Wh, varh, VAh: 9 digits (6-digit or 12-digit is also available.); Harmonic distortion ratio/content rate: 4 digits; Harmonic RMS value: 4 digits; Operating time: 6 digits
	Display update time interval		0.5 s, 1 s (selectable)
Communication		MODBUS RTU communication	
Connectable Optional Plug-in Module		Cannot connect optional module	
Power interruption backup		Use of nonvolatile memory (Items: settings, MAX/MIN value, active energy, reactive energy, apparent energy, operating time)	
VA consumption	Voltage circuit	Each phase: 0.1 VA (at 110 V AC), 0.2 VA (at 220 V AC), 0.4 VA (at 440 V AC)	
	Current circuit	Each phase: 0.1 VA	
	Auxiliary power circuit	4 VA (at 110 V AC), 5 VA (at 220 V AC), 3 W (at 100 V DC)	
Auxiliary power		100 V to 240 V AC (±15%), 100 V to 240 V DC (-30% +15%)	
Weight		0.3 kg	
Dimensions		96 (H) × 96 (W) × 36 (D) mm	
Mounting method		Embedded	
Operating temperature/humidity		-5°C to +55°C (Daily average temperature: 35°C or less), 0% to 85% RH, Non condensing	
Storage temperature/ humidity		-25°C to +75°C (Daily average temperature: 35°C or less), 0% to 85% RH, Non condensing	

Note 1. The class value is a percentage of rated value (100%).

Note 2. For harmonics measurement where distortion ratio (content rate) is 100% or more, it can exceed ±2.0%.

Note 3. When there is no voltage input, harmonic current cannot be measured.

Operating Instructions

Functions

LCD Functions

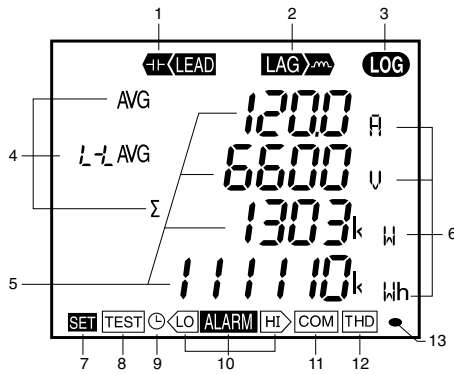

No.	Name of each part	Function																
1	LEAD status	Light up when leading reactive energy is measured																
2	LAG status	Light up when lagging reactive energy is measured																
3	Built-in logging status	Light up when the built-in logging function is operating																
4	Digital element display	Display measuring elements expressed in digital numbers																
5	Digital display	Display measured values in digital numbers																
6	Unit	Display the units of measured values																
7	Setup status	Light up in the setting mode Blink in the setting confirmation mode																
8	Test mode status	Light up in the test mode																
9	Clock status	Light up when the date and time are set																
10	Upper/lower limit alarm status	Blink when the upper/lower limit alarm is generating																
11	Communication/ Option logging status	<table border="1"> <thead> <tr> <th>Specification</th> <th>ON</th> <th>Blink</th> <th>OFF</th> </tr> </thead> <tbody> <tr> <td>CC-Link communication</td> <td>Normal</td> <td>CC-Link version mismatches, Hardware abnormality</td> <td>Hardware abnormality</td> </tr> <tr> <td>MODBUS RTU communication MODBUS TCP communication</td> <td>Normal</td> <td>Communication error such as wrong address *1</td> <td>Hardware abnormality</td> </tr> <tr> <td>Logging function</td> <td>Normal</td> <td>Error occurrence such as setting abnormality, SD memory card error, or battery voltage drop *1</td> <td>Hardware abnormality</td> </tr> </tbody> </table>	Specification	ON	Blink	OFF	CC-Link communication	Normal	CC-Link version mismatches, Hardware abnormality	Hardware abnormality	MODBUS RTU communication MODBUS TCP communication	Normal	Communication error such as wrong address *1	Hardware abnormality	Logging function	Normal	Error occurrence such as setting abnormality, SD memory card error, or battery voltage drop *1	Hardware abnormality
		Specification	ON	Blink	OFF													
		CC-Link communication	Normal	CC-Link version mismatches, Hardware abnormality	Hardware abnormality													
MODBUS RTU communication MODBUS TCP communication	Normal	Communication error such as wrong address *1	Hardware abnormality															
Logging function	Normal	Error occurrence such as setting abnormality, SD memory card error, or battery voltage drop *1	Hardware abnormality															
*1. For details, refer to User's Manual.																		
12	Harmonics status	Light up when harmonic is displayed																
13	Metering status	Blink when Imported active energy is measured *Note 1 *It appears on the imported active energy display screen only																

Note 1. The blinking cycle is constant regardless of measuring input size.

Button Functions

Basic performance		Special performance	
Button operation	Functions	Button operation	Functions
SET	Used to set items such as primary voltage and current, and to choose setting items	DISPLAY (Push for 2 seconds)	Used to switch display between manual display change ↔ cyclic display change
+ or -	Used to switch display between setting	PHASE (Push for 2 seconds)	Used to switch display between manual phase change ↔ cyclic phase change
MAX/MIN	Used to switch display between max/min values and instantaneous value	+ + - (Push for 2 seconds)	Used to change Wh, etc. to another unit and to low order zoom display
PHASE	Used to change over phase	+ + RESET (Push for 2 seconds)	Used to perform batch reset of all the max/min values
DISPLAY	Used to change over the display screen	+ or - (Push for 1 seconds)	Used to perform fast-forward or fast-return of numerical values in numerical value setting
		SET + RESET + PHASE (Push for 2 seconds)	Used to reset Wh, varh, and VAh to zero by concurrently pushing for 2 seconds

Note. An example. For details, refer to the user's manual.

Set-up

For correct measurement, it is necessary to set the primary voltage/current in the set-up mode.

Enter the setting mode from the operating mode and set the necessary items. Any items not set remain in the factory default.

Set-up workflow (Example for ME96SSHB-MB)

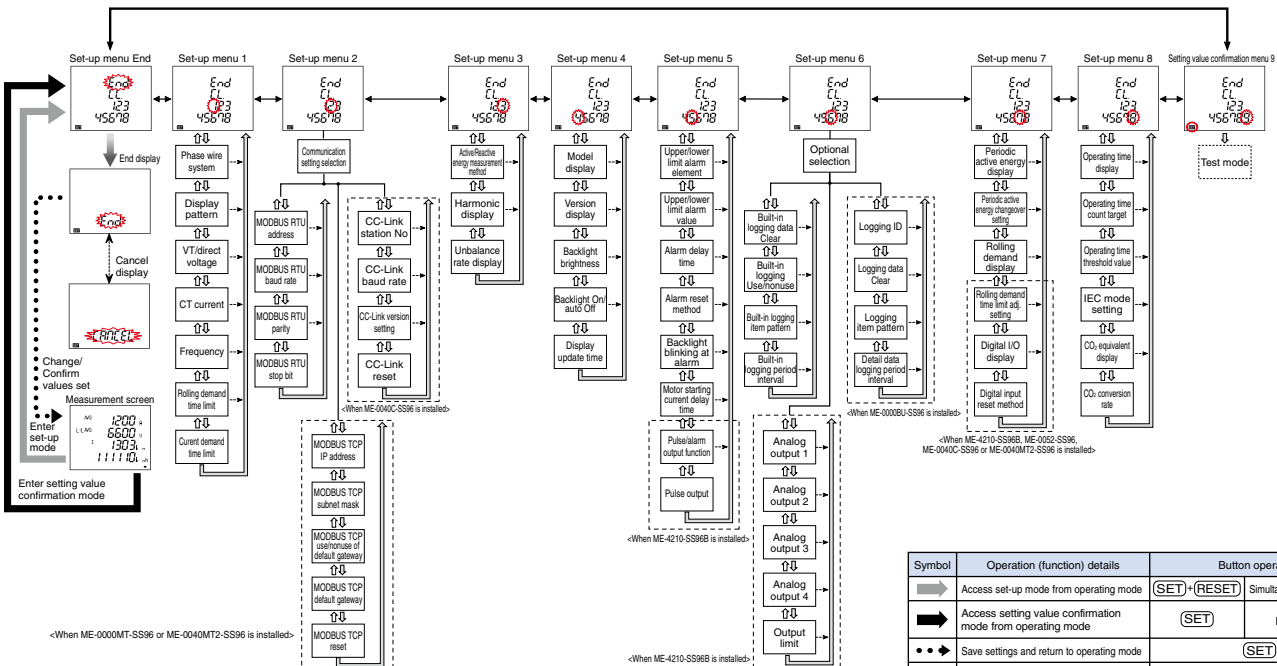

Notes 1. Basic measurements are possible by adjusting settings in the menu 1 () area enclosed by dotted line.
 Notes 2. Item settings vary depending on the model.
 Notes 3. Setting confirmation menu 9 (test mode) is not displayed in the setting mode.

Symbol	Operation (function) details	Button operation
→	Access set-up mode from operating mode	SET + RESET Simultaneously press for 2 s
→	Access setting value confirmation mode from operating mode	SET Press for 2 s
◆◆◆	Save settings and return to operating mode	SET
←	Select set-up menu	+ or -
→	Move to next screen	SET
←	Return to previous setting item	DISPLAY
→	Skip remaining settings	SET Press for 1 s
←	Select cancel	+ or -

External Dimensions, Installation and Connections

Dimensions

ME96SSHB-MB, ME96SSRB-MB

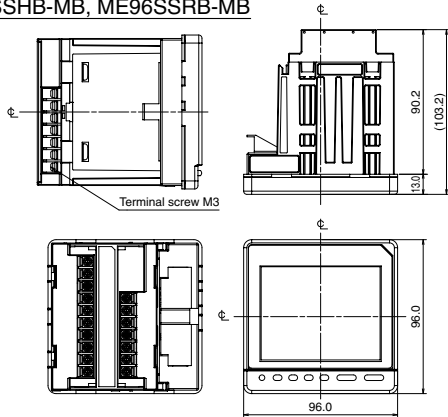

ME96SSEB-MB

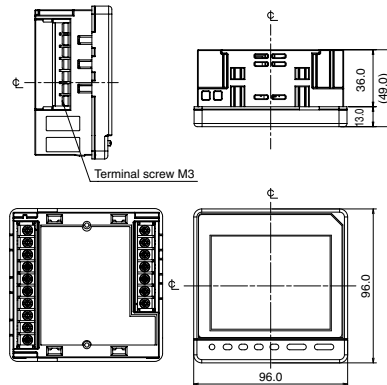

Optional Plug-in Module :
ME-4210-SS96B,
ME-0040C-SS96, ME-0052-SS96

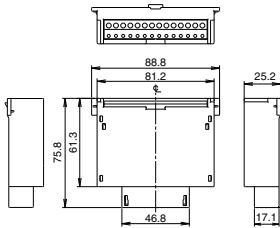

Optional Plug-in Module :
ME-0000BU-SS96

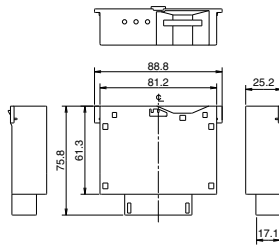

Optional Plug-in Module :
ME-0000MT-SS96

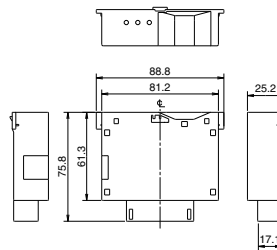

Optional Plug-in Module :
ME-0040MT2-SS96

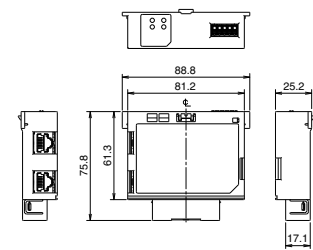

Mounting

1 Dimension of panel

Panel hole dimensions are as shown in the following figure. It can be attached to a panel with thickness of 1.6 to 4.0 mm.

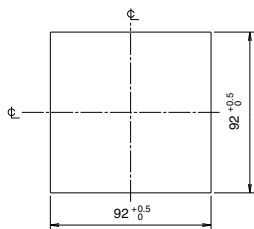

2 View Angle

The contrast of the display changes at view angle. Mount it at the position that is easy to see.

ME96SSEB-MB

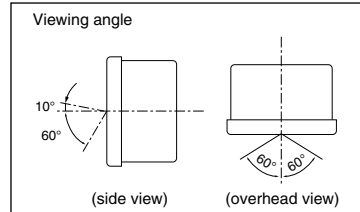

ME96SSHB-MB/ME96SSRB-MB

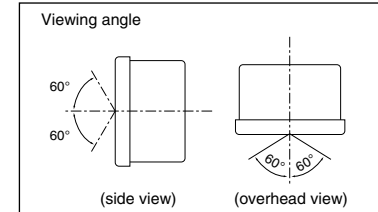

3 Attachment

For attachment of the basic device into the panel hole, attach according to the following procedure.

- ① The attachment lug is installed in two holes of the top and bottom of the basic device.
- ② Tighten the screws of the lug, and fix onto the panel.

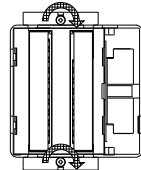
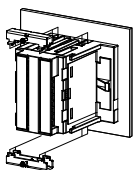

Note To prevent damage to the panel and screws, do not overtighten the screws.
The recommended torque for this product is 0.3 N·m to 0.5 N·m (about half the normal torque).
Tighten the two screws evenly.

Main unit mounting screws: M3

4 Installing Optional Plug-in Module

When installing the optional plug-in module onto the basic device, install according to the following procedure.

- ① Remove the optional cover.
- ② Attach the optional unit to the main unit.

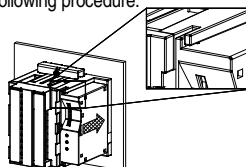
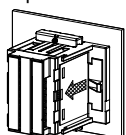

Fit the protruding part of the optional unit into the slot in the main unit.

Wiring

1 Applicable Cable Size

Product type	Screw type	Wire for use	Tightening torque
ME96SSHB-MB, ME96SSRB-MB	M3	For crimped terminal: AWG 26 to 14 (Connection up to two wires) Appropriate crimped terminal: One for M3 screw 6.0 mm or less in outer diameter.	0.8 N·m
ME96SSEB-MB			0.5 N·m
Optional plug-in module: ME-4210-SS96B, ME0052-SS96, ME-0040C-SS96	Non-screw	Single wire, Stranded wire: AWG 24 to 14 (For stranded wire, possible in combination with rod terminals) The peeling size of the cable sheath: 10 to 11 mm *1: If complying with UL standards, follow the conditions listed below. • Single wire, Stranded wire: AWG 24 to 18 • Rod terminals are not available. *2: When using a rod terminal with insertion points of two wires, select the terminal that insertion hole depth of the terminal block is 12 to 13 mm as a guide.	—
Optional plug-in module: ME-0040MT2-SS96	Non-screw	Single wire, Stranded wire: AWG 24 to 16 (For stranded wire, possible in combination with rod terminals) The peeling size of the cable sheath: 8 mm Rod terminals (without plastic sleeve): 0.2 to 1.5 mm ² Rod terminals (with plastic sleeve): 0.2 to 0.75 mm ²	—

2 Wiring

Optional Plug-in Module Terminal

- Peel the wire tip or pressure-weld a rod terminal.
- Insert the wire with the lever pressed and then release the lever to connect.

Optional Plug-in Module Terminal

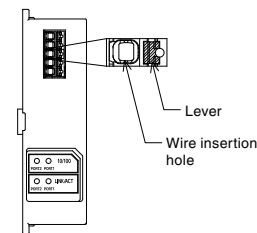
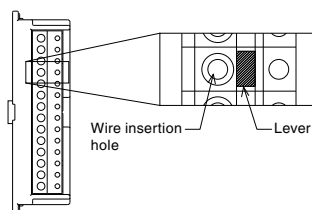

3 Confirmations

After wiring, make sure the following:

- All wiring is connected
- There is no mistake in wiring

Note

Protective sheet

There is a protective sheet covering the LCD screen to prevent scratching during panel installation. Please remove the sheet before using the meter. When removing the sheet, the LCD may turn on due to the static electricity generated. This is not abnormal; the LCD will turn off after a short time.

Installation position

If installing the unit at the panel edge, choose an installation position where there is sufficient space for wiring work.

Optional unit

Turn the auxiliary power supply off before attaching the optional unit. If attached with the power on, the main unit will not recognize the optional unit. To remedy this, turn off/restart the auxiliary power supply or execute the "instrument restart" operation.

Wiring Diagrams

3-phase 4-wire system: Direct input

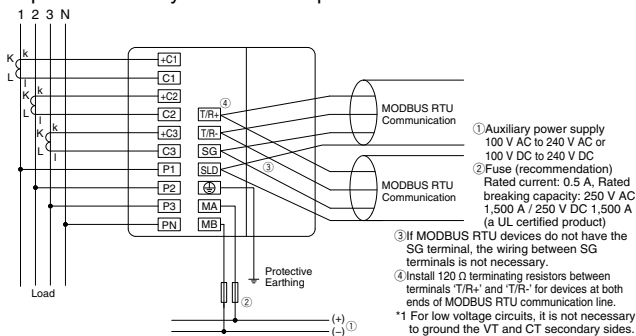

3-phase 4-wire system: With VT

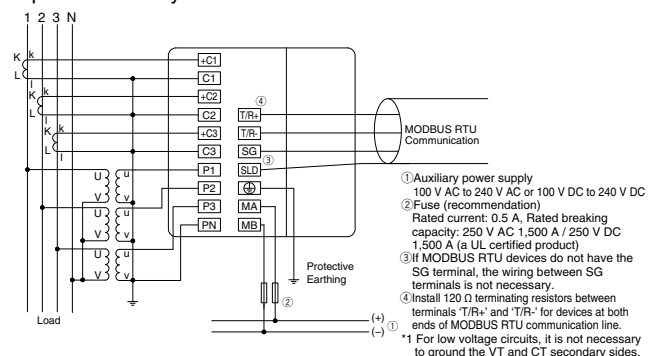

3-phase 3-wire system: Direct input, 2CT

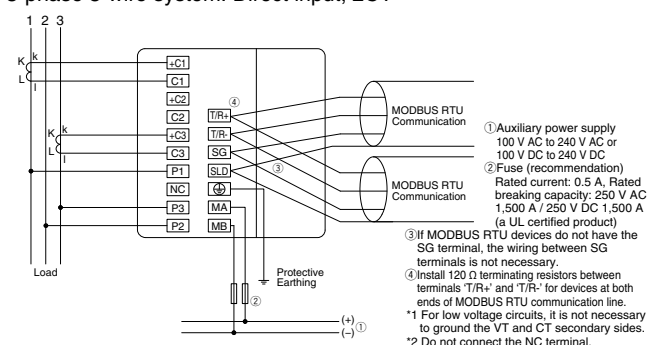

3-phase 3-wire system: With VT, 3CT

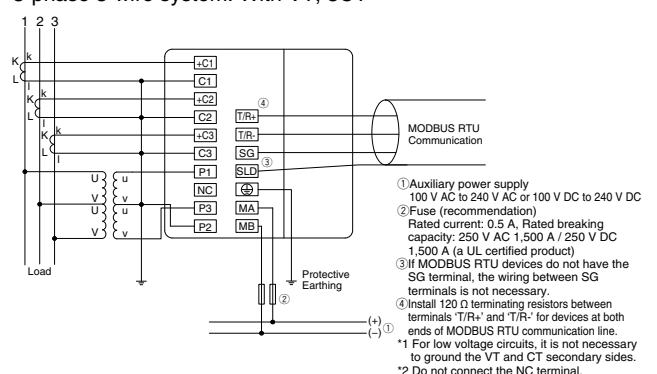

External Dimensions, Installation and Connections

Wiring Diagrams (Continued)

1-phase 3-wire system

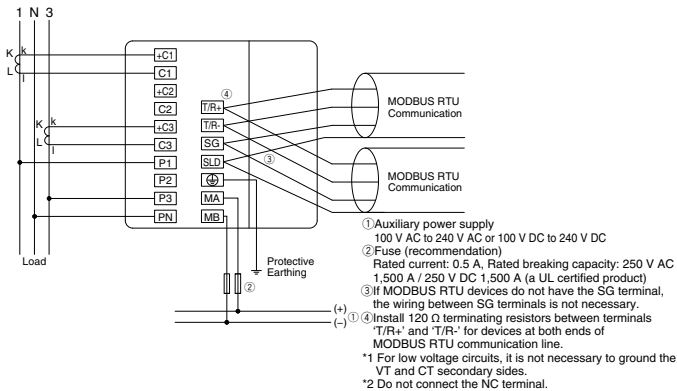

1-phase 2-wire system: With VT

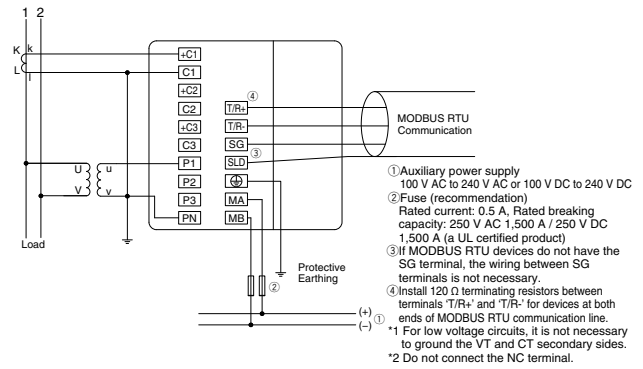

Note

1. The voltage input terminal will vary depending on if it is a 3-phase, 3-wire system or otherwise.
2. VT/CT polarity errors will cause incorrect measurement.
3. Always use the grounding terminal (⊕) in a grounded state. Perform grounding with a grounding resistance of 100 Ω or less. Insufficient grounding may cause erroneous operation.
4. Use shielded twisted-pair cables for transmission signal lines.
5. Install 120 Ω terminating resistors between terminals "T/R+" and "T/R-" for devices at both ends of MODBUS RTU communication line.
6. Use the thickest possible grounding wire to ensure low impedance.
7. MODBUS RTU communication signal cables must not be in close proximity or bundled with high-voltage cables.

Optional Plug-in Module: ME-4210-SS96B

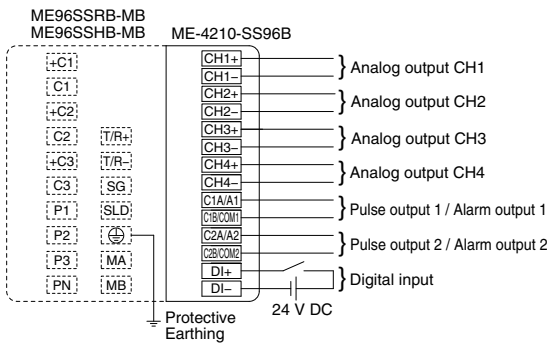

Optional Plug-in Module: ME-0040C-SS96

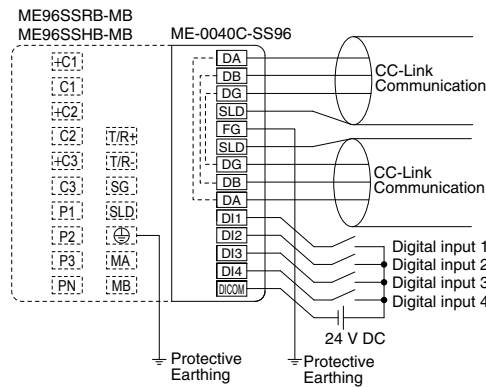

Optional Plug-in Module: ME-0052-SS96

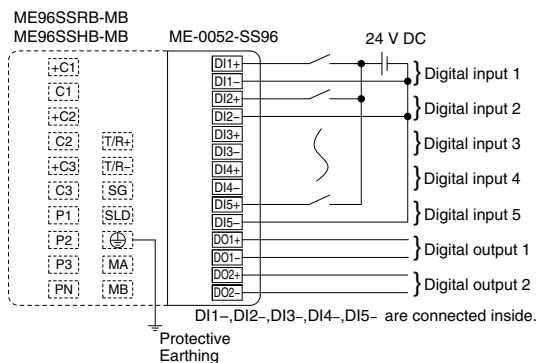

Optional Plug-in Module: ME-0000MT-SS96

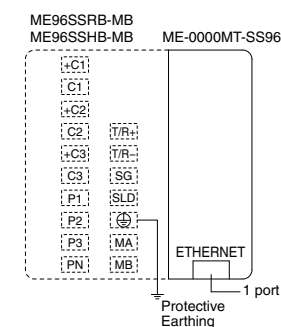

Optional Plug-in Module: ME-0000BU-SS96

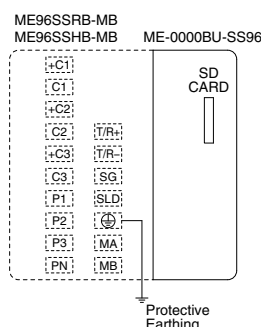

Optional Plug-in Module: ME-0040MT2-SS96

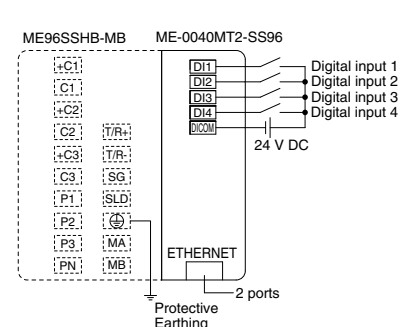

Wiring Diagrams (Continued)

Note

1. Pulse output, alarm output, and digital input/output cables must not be in close proximity or bundled with power cables or high-voltage cables. When laid parallel, separate by the distance shown in the following table.

Condition	Distance
Power lines of 600 V AC or less	300 mm or more
Other power lines	600 mm or more

2. Analog output cables must not be in close proximity or bundled with other power cables or input cables (e.g., VT, CT, auxiliary power supply). In addition, to prevent noise, surge and induction, use shielded cables or twisted-pair cables. Make sure that cables are as short as possible.
3. There is no insulation between the MODBUS RTU communication portion and the optional module ME-4210-SS96B, ME-0040C-SS96.
4. Use only designated cables when connecting the CC-Link (see communication specifications). CC-Link dedicated cables cannot be used at the same time as CC-Link dedicated high-performance cables. Normal data transmission cannot be guaranteed if used at the same time.
The terminal resistance value varies depending on the type of dedicated cable.
5. For cables connecting the CC-Link, connect shielded cables to "SLD" and ground "FG" cables. "SLD" and "FG" cables are connected inside the unit.
6. CC-Link communication lines are small signal circuits: separate from strong electrical circuits by a distance of 10 cm or more, or 30 cm or more if laid in parallel over a long distance.
Ground the terminal before use.
7. For CC-Link communication, always use dedicated lines and comply with conditions for total wiring distance, distance between stations and terminal resistance values according to the communication speed. Not doing so may prevent normal communication (see the CC-Link Master Unit Operations Manual for information on dedicated lines and wiring conditions).
8. The terminal resistance supplied with the CC-Link Master Unit must always be used for the units at both ends of the CC-Link communication line. If the meter is at the end of the CC-Link communication line, connect it between the DA and DB terminals.
9. Communication errors may occur under the influence of high-frequency noise from other devices in the installation environment during high-speed communication (100 Mbps) via 100BASE-TX connection of MODBUS TCP.
Measures to be taken when the network system is configured to avoid the influence of high-frequency noise are shown below.
 - (1) Wiring connection
 - When laying a twisted pair cable, do not bundle the cable together with any main circuit line or power line or lay it close to such a line.
 - Keep the twisted pair cables in the duct.
 - (2) Communication method
 - Increase the number of communication retries as needed.
 - Replace the hub to be used for connection with that for 10 Mbps, and communicate at a data transmission speed of 10 Mbps.
10. Do not connect any terminal or RJ45 connector in the live state.
11. Do not insert or remove the SD memory card in the live state.

Rated voltage for each phase/wire system

Phase/Wire	Connection	Rated voltage	Figure
3-phase 4-wire	Star	Max. 277 V AC (L-N)/480 V AC (L-L)	Figure 1
3-phase 3-wire	Delta	Max. 220 V AC (L-L)	Figure 2
	Star	Max. 440 V AC (L-L)	Figure 3
1-phase 3-wire	-	Max. 220 V AC (L-N)/440 V AC (L-L)	Figure 4
1-phase 2-wire*	Delta	Max. 220 V AC (L-L)	Figure 5
	Star	Max. 440 V AC (L-L)	Figure 6

* The circuit derived from the 3-phase 3-wire delta connection and the 1-phase 2-wire transformer circuit have the maximum rating of 220 V AC.
The circuits derived from the 3-phase 4-wire and 3-phase 3-wire star connections and 1-phase 3-wire connection have the maximum rating of 440 V AC.

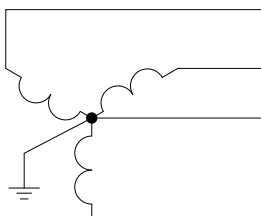

Fig. 1. 3-phase 4-wire (star)

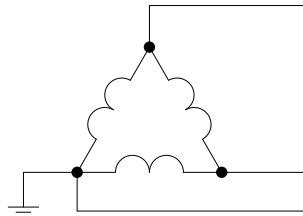

Fig. 2. 3-phase 3-wire (delta)

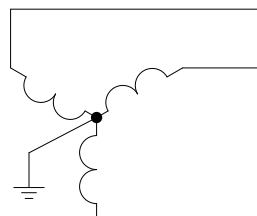

Fig. 3. 3-phase 3-wire (star)

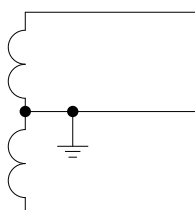

Fig. 4. 1-phase 3-wire

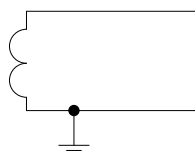

Fig. 5. 1-phase 2-wire (delta)

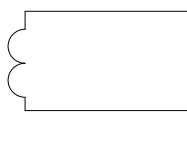

Fig. 6. 1-phase 2-wire (star)