



Electronic Multi-Measuring Instrument

MODEL

ME96SSEB-MB

User's Manual: Detailed Edition



- Before use, you should read this user's manual carefully to properly use this instrument.
Be sure to forward the manual to the end user.

Check your delivery

The following table shows a list of the instrument accessories.
When unpacking your package, check all the contents.

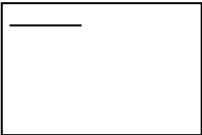
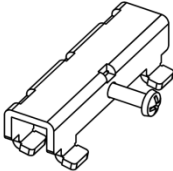
Contents	Quantity	Specification
User's Manual (Digest version)	1	 A3 size
Attachment lug (with a screw)	2	

Optional plug-in module

The optional plug-in modules cannot be attached to this product.
If you need a function such as analog output, CC-Link communication, digital input/output, MODBUS TCP communication, or logging function, use other model, ME96SSHB-MB or ME96SSRB-MB which can be combined with the optional plug-in modules.

Features

- The instrument measures load status by wiring the secondary sides of VT (Voltage Transformer) and CT (Current Transformer) in the power receiving and distribution system and displays various measured values.
- The instrument supports Active Energy Class 0.5S.
- The password protection prevents undesired setting change and measured data deletion.
- The transmission function, MODBUS RTU communication, transmits measured data to superior monitoring systems.
- The instrument fulfills the requirements of the CE marking, UL standards, KC mark, and FCC/IC.
- The support function for checking input wiring enables to determine the wiring condition in the test mode. When either a voltage input or current input is incorrectly wired, the incorrect wiring part is displayed on the screen and it also shows a current phase angle, a voltage phase angle, and each value of active power, voltage, and current.

Trademark

MODBUS is a trademark of Schneider Electric USA Inc.

Other company and product names herein are trademarks or registered trademarks of their respective owners. In the text, trademark symbols such as "TM" and "®" may not be written.

Table of Contents

Check your delivery	1
Optional plug-in module	1
Features	2
Trademark	2
Table of Contents	3
Safety Precautions	5
EMC Directive Instruction	9
Precautions for KC mark	9
Table for measuring element code	10
1. Name and Function of Each Section	11
1.1. Name of Each Part	11
1.2. LCD Function	12
1.3. Function of Operation Buttons	13
2. Each Mode Function	15
3. How to Set up	16
3.1. Setting Flow	16
3.2. Setting Menu 1: Basic Setup (Settings for Phase Wire System, Display Pattern, VT/Direct Voltage, and CT Primary Current)	19
3.3. Setting Menu 2: Communication Settings (MODBUS RTU Communication Settings)	23
3.4. Setting Menu 3: Display Settings (Settings for Display of Active/Reactive Energy and Harmonic Measurement)	24
3.5. Setting Menu 4: LCD Settings (Settings for Model Display, Version Display, Backlight, and Update Time)	25
3.6. Setting Menu 5: Alarm Settings (Settings for Upper/Lower Limit Alarm and Motor Starting Current Mask Function)	26
3.7. Setting Menu 6: No Settings	29
3.8. Setting Menu 7: No Settings	29
3.9. Setting Menu 8: Special Settings (Settings for Operating Time and IEC Mode)	30
3.10. Setting Confirmation Menu 1 to 9: How to Confirm the Settings in the Setting Menu 1 to 8, 9 Test Mode	32
3.11. Initialization of Related Items by Changing a Setting	33
3.12. Initialization of All Settings	33
3.13. Settings for Special Display Pattern P00	34
3.14. Example for Easy Setup	36
4. How to Use Test Mode	38
4.1. Test Menu 1: Communication Test	39
4.2. Test Menu 2 to 5: No Test Menu	40
4.3. Test Menu 6: Functions for Determining Incorrect Wiring	40
4.3.1. Incorrect Wiring Patterns Detected by <u>①Pattern display of incorrect wiring</u>	43
5. Operation	46
5.1. Basic Operation	46
5.1.1. How to Switch the Measurement Screen	46
5.1.2. How to Switch Phase Display	46
5.1.3. How to Display in Cyclic Mode	47
5.1.4. Harmonics Display	47
5.1.5. Maximum/Minimum Value Display	48
5.1.6. How to Display Maximum/Minimum values	48
5.1.7. How to Clear the Maximum/Minimum Values	48
5.1.8. Active Energy/Reactive Energy/Apparent Energy Display	49
5.1.9. How to Change the Display Digit of Active/Reactive/Apparent Energy	49
5.1.10. How to Reset Active/Reactive/Apparent Energy to Zero	50
5.1.11. How to Measure Reactive Energy (2 quadrant/4 quadrant measurement)	50
5.1.12. Each Measuring Item Display during Power Transmission	51
5.1.13. Demand Time Period and Demand Value of Current demand	51

Table of Contents

5.2. Usage Depending on the Application (Alarm, Operating Time, Password, etc.)	52
5.2.1. Upper/Lower Limit Alarm Display and Action	52
5.2.2. How to Cancel the Upper/Lower Limit Alarm.....	53
5.2.3. How to Stop Backlight Blinking Caused by the Upper/Lower Limit Alarm.....	53
5.2.4. Operating Time Display	53
5.2.5. How to Reset Operating Time to Zero.....	53
5.2.6. How to Prevent the Maximum Value Update by Motor Starting Current.....	54
5.2.7. Password Protection Setting.....	54
6. Others.....	55
6.1. Display Pattern List.....	55
6.2. Standard Value.....	57
6.3. Measuring Item.....	59
6.4. Instrument Operation.....	61
6.5. Troubleshooting.....	62
7. Installation.....	63
7.1. Dimensions.....	63
7.2. How to Install	64
7.2.1. Mounting Hole Dimensions	64
7.2.2. Mounting Position	64
7.2.3. Mounting and Fixing.....	64
7.3. How to Connect Wiring.....	65
7.3.1. Specifications on the Applicable Electrical Wire.....	65
7.3.2. Wiring of the Unit	65
7.3.3. Check the connection	65
7.4. Wiring Diagram.....	67
8. Specifications.....	72
8.1. Product Specifications	72
8.2. Compatible Standards	73
8.3. MODBUS RTU Communication Specifications.....	73
8.4. Setting Table (Factory Default Settings and Customer's Notes Settings)	74
9. Appendix.....	75
9.1. ME96SS Calculation Method (3-phase Unbalanced System with Neutral)	75
9.2. A List of Examples for Incorrect Wiring Display	76
9.2.1. 3-phase 4-wire System	76
9.2.2. 3-phase 3-wire System	85
9.2.3. 1-phase 3-wire System	92

Safety Precautions

Before use, read these instructions carefully to properly operate the instrument.

Be sure to follow the precautions described here for personnel and product safety.

Keep this manual ready to hand and accessible for future use at all times.

Be sure to forward the manual to the end user.

If you consider using the instrument for a special purpose such as nuclear power plants, aerospace, medical care, or passenger vehicles, consult with our sales representative.

The instructional icon in the manual is described as follows.



The caution icon (Δ) on the main unit indicates that incorrect handling may cause hazardous conditions. Always follow the subsequent instructions (Δ_{CAUTION}) because they are important to personal safety. Failure to follow them may result in an electric shock, a fire, erroneous operation, or damage to the instrument. If the instrument is used in a manner not specified by the manufacturer, the protection provided by the instrument may be impaired.



The terminals of auxiliary power (MA, MB) and voltage input (P1, P2, P3, PN) have hazards of electric shock, explosion, or arc flash. Turn off the power supply of auxiliary power and input circuit and then handle the instrument.

■ Precautions on use environment and conditions

Do not use the instrument in the following circumstances:

Failure to follow the instruction may cause a malfunction or reduced product life time.

- The ambient temperature exceeds the range -5°C to $+55^{\circ}\text{C}$.
- The average daily temperature exceeds $+35^{\circ}\text{C}$.
- The relative humidity exceeds the range 0 to 85% RH, or condensing.
- The altitude exceeds 2000 m.
- Pollution Degree: more than 2 *Note 1
- Exposed to much dust, corrosive gas, salty environment, or oil mist
- Transient over voltage: 4000 V *Note 1
- Exposed to excessive vibration or impact
- Exposed to rain or water drops
- Exposed to direct sunlight
- Pieces of metal or inductive substances are scattered.
- Exposed to strong magnetic fields or large exogenous noise

*Note1: For details about the Pollution Degree and the Transient over voltage category, refer to EN61010-1:2010.

Grit, dust, and small insects cause poor contact or a failure such as insulation decline that caused by deposition and moisture absorption. Furthermore, in the area where the air contains conductive dust, a failure such as a product malfunction or insulation deterioration occurs in a relatively short time. In this case, you must take measures against it such as putting the instrument in an enclosed board. In addition, if the temperature inside the board rises, the measures must be undertaken as well.

Safety Precautions

■ Precautions on Installation and wiring

Be sure to read the instructions carefully before installation and wiring.

- A qualified electrician must install and wire the instrument for safety.
- Supply power to the instrument after completing its assembly work on a cabinet door.
- The instrument is to be mounted on the cabinet door. All connections must be kept inside the cabinet.
- The following table shows the specifications on the input/output terminal.

■ Auxiliary power supply and measuring element

Auxiliary power supply		100 to 240 V AC ($\pm 15\%$) 50 Hz to 60 Hz 100 to 240 V DC (-30% +15%)	MA, MB terminals
Measuring element	Voltage	3-phase 4-wire: max 277 V AC/480 V AC 3-phase 3-wire: (DELTA) max 220 V AC (STAR) max 440 V AC 1-phase 3-wire: max 220 V AC/440 V AC 1-phase 2-wire: (DELTA) max 220 V AC (STAR) max 440 V AC	Category III P1, P2, P3, PN terminals
	Current	5 A (CT secondary side), max 30 V AC	Category III +C1, C1, +C2, C2, +C3, C3 terminals
	Frequency	50 Hz or 60 Hz	

The current input terminals must be connected to a CT, external equipment, with basic insulation.

Be sure to continuously connect the terminals for voltage-measuring purpose and current-measuring purpose during operation.

■ Others

MODBUS RTU communication	T/R+, T/R-, SG terminals	max 35 V DC
--------------------------	--------------------------	-------------

- Keep the protection sheet affixed to the front of the instrument during installation and wiring.
- Do not drop the instrument from high place. If it is dropped and the display cracks, do not touch the liquid leaking from the broken LCD or do not get it in your mouth. If you touch the liquid, rinse it off with soapy water at once.
- Do not work under live-line condition. Otherwise, an instrument failure, an electric shock, or a fire may be caused.
- When tapping or wiring, take care not to enter any foreign objects such as chips or wire pieces into the instrument.
- If you pull the wires with a strong force when connecting them to the terminals, the terminals may come off. (Tensile load: 39.2N or less)
- Check the wiring diagram carefully. Inappropriate wiring can cause a failure of the instrument, an electric shock, or a fire.
- Use appropriate size wires. The use of an inappropriate size wire can cause a fire due to heat generation.
- Use crimp-type terminals compatible with the wire size. For details, refer to **7.3.1 Specifications on the Applicable Electrical Wire**. The use of an inappropriate terminal can cause a malfunction, failure, or burnout of the instrument or a fire due to damage to the terminal or poor contact.
- Tighten the terminal screws with a specified torque and use a suitable pressure connector. For details, refer to **7.3.1 Specifications on the Applicable Electrical Wire**. Excessive tightening can cause damage to the terminals and screws.
- Be sure to confirm the wiring connections strictly after the connection. Poor connection can cause a malfunction of the instrument, an electric shock, or a fire.
- In order to prevent invasion of noise, MODBUS RTU communication cables, auxiliary power supply cables, and other signal cables must not be placed close to or bound together with power lines or high voltage lines. When lying parallel to the power lines or high voltage lines, refer to the following table for the separation distance. (Except the input part of the terminal block)

Conditions	Distance
Power lines of 600 V AC or less	300 mm or more
Other power lines	600 mm or more

 CAUTION

Safety Precautions

■ Precautions on preparation before use

- Observe the use conditions and environment requirements for installation place.
- You must set up the instrument before use. Read the manual carefully to set it up correctly. If the setup is incorrectly done, the instrument will not be properly operated.
- Check the power rating of the instrument and then apply proper voltage.

■ Precautions on how to use

- When operating the instrument, check that active bare wires do not exist around it. If any bare wire exists, stop the operation immediately and then take appropriate action such as insulation protection.
- If a power outage occurs during the setup, the instrument will not be set up correctly. Set it up again after power recovery.

	<ul style="list-style-type: none">● Do not disassemble or modify the instrument to use. Otherwise, a failure, an electric shock, or a fire can be caused.● Use the instrument within the rating specified in the manual. If you used it outside the rating, it might cause not only a malfunction or failure of the instrument but also ignition or burnout.● Do not open the CT secondary side while the primary current is energized. When the CT secondary side circuit is open, the primary current flows. However, the secondary current does not flow. Therefore, a high voltage is generated at the CT secondary side and the temperature rises, resulting in insulation breakdown in the CT secondary winding. It may lead to burnout.● When external equipment is connected to the external terminals, the instrument and external equipment must not be powered and be used after the definitive assembly on a cabinet door.● The rating of the terminal of external equipment should satisfy that of the external terminal of the instrument.
---	--

■ Precautions on maintenance

- Wipe dirt off the surface with a soft dry cloth.
- Do not leave a chemical cloth in contact with the instrument for a long time or do not wipe it with benzene, thinner, or alcohol.
- In order to properly use the instrument for a long time, conduct the following inspections:
 - (1) Daily maintenance
 - ① No damage in the instrument
 - ② No abnormality with LCD indicator
 - ③ No abnormal noise, smell or heat generation
 - (2) Periodical maintenance

Inspect the following item every six months to once a year.

 - ① No looseness of installation and terminal block connection

	<p>Be sure to conduct periodic inspection under the electric outage condition. Failure to follow the instruction may cause a failure of the instrument, an electric shock, or a fire. Tighten the terminals regularly to prevent a fire.</p>
---	--

■ Precautions on storage

To store the instrument, turn off the power supplies of auxiliary power and input circuit, remove the wires from the terminals, and then put them in a plastic bag.

For long-time storage, avoid the following places. Otherwise, there is danger of an instrument failure or reduced product life time.

- The ambient temperature exceeds the range -25°C to $+75^{\circ}\text{C}$.
- The average daily temperature exceeds $+35^{\circ}\text{C}$.
- The relative humidity exceeds the range 0 to 85% RH, or condensing.
- Exposed to much dust, corrosive gas, salty environment, or oil mist.
- Exposed to excessive vibration or impact.
- Exposed to rain or water drops.
- Exposed to direct sunlight.
- Pieces of metal or inductive substances are scattered.

Safety Precautions

■ Warranty

- The warranty period is for one year from the date of your purchase or 18 months after the manufacturing date, whichever is earlier.
- During the warranty period, if any failure occurred in standard use that the product is used in the condition, method, and environment followed by the conditions and precautions described in the catalog and user's manual, we would repair the product without charge.
- Even within the warranty period, non-free repair is applied to the following cases.
 - ① Failures caused by the customer's improper storage, handling, carelessness, or fault.
 - ② Failures caused by faulty workmanship
 - ③ Failures due to faults in use or undue modification
 - ④ Failures due to force majeure such as a fire or abnormal voltage or due to natural disasters such as earthquakes, windstorms, or floods.
 - ⑤ Failures caused by the problem in question that could not be predicted with the technology available at the time the product was shipped.
- Our company shall not be liable to compensate for any loss arising from events not attributable to our company, customers' opportunity loss or lost earnings due to failure of the product, any loss, secondary loss, or accident caused by a special reason regardless of our company's predictability, damage to other products besides our products, or other operations

■ Replacement cycle of product

It is recommend that you renew the product every ten years although it depends on your use condition. The long-term use of the product may cause discoloration of the LCD or a product malfunction.

■ Disposal

- Treat the product properly as industrial waste.
- Batteries are not used for this product.

■ Packaging materials and user's manual

For reduction of environment load, cardboard is used for packaging materials and the manual is printed with recycled papers.

EMC Directive Instruction

This section summarizes the precautions to have the cabinet constructed with the instrument conform to the EMC Directive.

However, the method of conformance to the EMC Directive and the judgment on whether or not the cabinet conforms to the EMC Directive must be determined finally by the manufacturer.

This instrument complies with part 15 of the FCC Rules. Operation is subject to the following two conditions: (1) This instrument may not cause harmful interference, and (2) this instrument must accept any interference received, including interference that may cause undesired operation.

This equipment is class A as per EN 55011. This equipment is not intended for use in residential environments and may not provide adequate protection to radio reception in such environments.

1. EMC Standards

- EN 61326-1
- EN 61000-3-2
- EN 61000-3-3

2. Installation (EMC directive)

The instrument is to be mounted on the panel of a cabinet.

Therefore, the installation to the cabinet is important not only for safety but also for conformance to EMC.

The instrument is examined in the following conditions.

- A conductive cabinet must be used.
- The conductivity of the six surfaces of the cabinet must be all ensured.
- The cabinet must be grounded by thick wires for low impedance.
- The hole drilling dimensions on the cabinet must be 10 cm or less in diameter.
- The terminals for protective earth and functional earth must be grounded by thick wires for low impedance. The use of the terminal for protective earth is important not only for safety but also for conformance to EMC.
- The connecting part of the terminal must be all placed inside the cabinet.
- Wiring outside the cabinet must be conducted with shielded cables, and the cables must be fixed to the panel with clamps. (Strip the covering of shielded cable by a portion of clamp installation and then mask the grounding part of the panel and clamp so as not to be painted.)

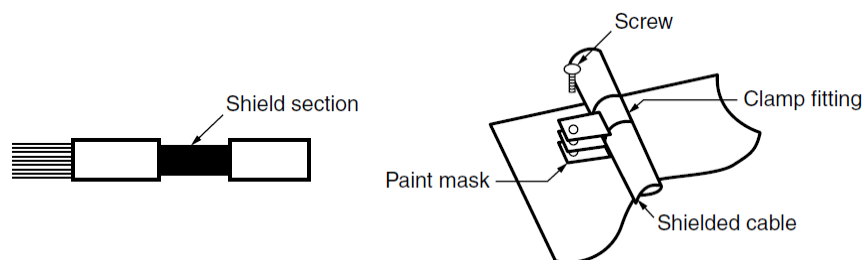

Precautions for KC mark

사용자안내문

이 기기는 업무용 환경에서 사용할 목적으로 적합성평가를 받은 기기로서 가정용 환경에서 사용하는 경우 전파간섭의 우려가 있습니다.

■ Precautionary note written in Korean

This device has undergone a conformity assessment for use in a commercial environment and may cause radio wave interference when used in a home environment.

■ Applicant for KC mark : MITSUBISHI ELECTRIC AUTOMATION KOREA CO.,LTD

■ Manufacturer : MITSUBISHI ELECTRIC CORPORATION

Note 1: This is the notification for the KC mark (Korea Certification)

Table for measuring element code

The following table shows a list of measuring element codes used in the manual.

Measuring element code	Measuring element name
A1	Current, 1-phase
A2	Current, 2-phase
A3	Current, 3-phase
AN	Current, N-phase
A _{AVG}	Current, average
DA1	Current demand, 1-phase
DA2	Current demand, 2-phase
DA3	Current demand, 3-phase
DAN	Current demand, N-phase
DA _{AVG}	Current demand, average
V12	Voltage, between 1-2 lines
V23	Voltage, between 2-3 lines
V31	Voltage, between 3-1 lines
V _{AVG} (L-L)	Voltage, average, line to line
V1N	Voltage, 1N-phase
V2N	Voltage, 2N-phase
V3N	Voltage, 3N-phase
V _{AVG} (L-N)	Voltage, average, line to neutral
W1	Active power, 1-phase
W2	Active power, 2-phase
W3	Active power, 3-phase
ΣW	Active power, total
var1	Reactive power, 1-phase
var2	Reactive power, 2-phase
var3	Reactive power, 3-phase
Σvar	Reactive power, total
VA1	Apparent power, 1-phase
VA2	Apparent power, 2-phase
VA3	Apparent power, 3-phase
ΣVA	Apparent power, total
PF1	Power factor, 1-phase
PF2	Power factor, 2-phase
PF3	Power factor, 3-phase
ΣPF	Power factor, total
Hz	Frequency
Wh	Active energy
varh	Reactive energy
VAh	Apparent energy
HI	Harmonic current
HI _N	Harmonic current, N-phase
HV	Harmonic voltage
THD _i	Harmonic current total distortion ratio
THD _v	Harmonic voltage total distortion ratio

1. Name and Function of Each Section

1.1. Name of Each Part

■ The front of the unit

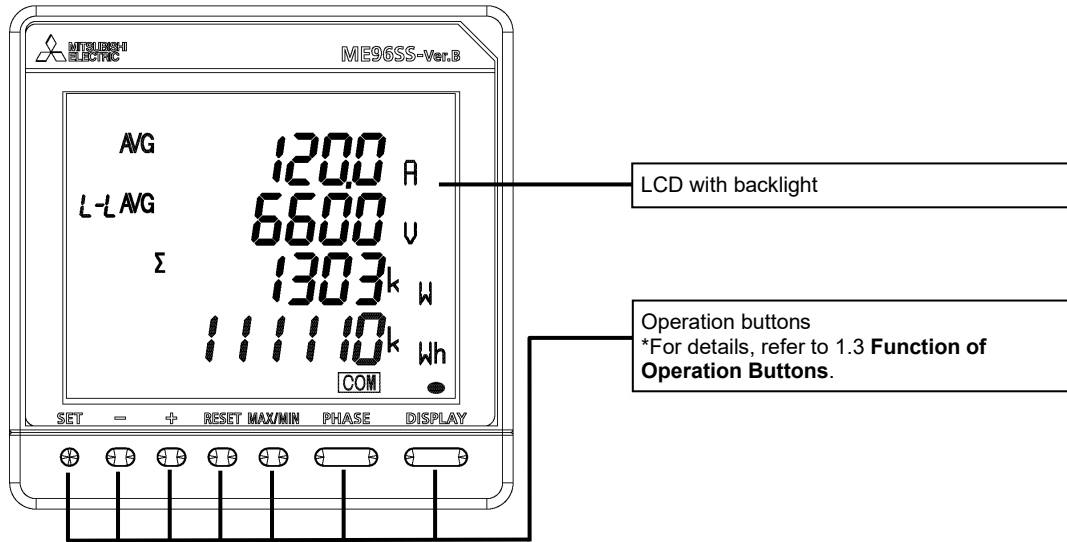

■ The back of the unit

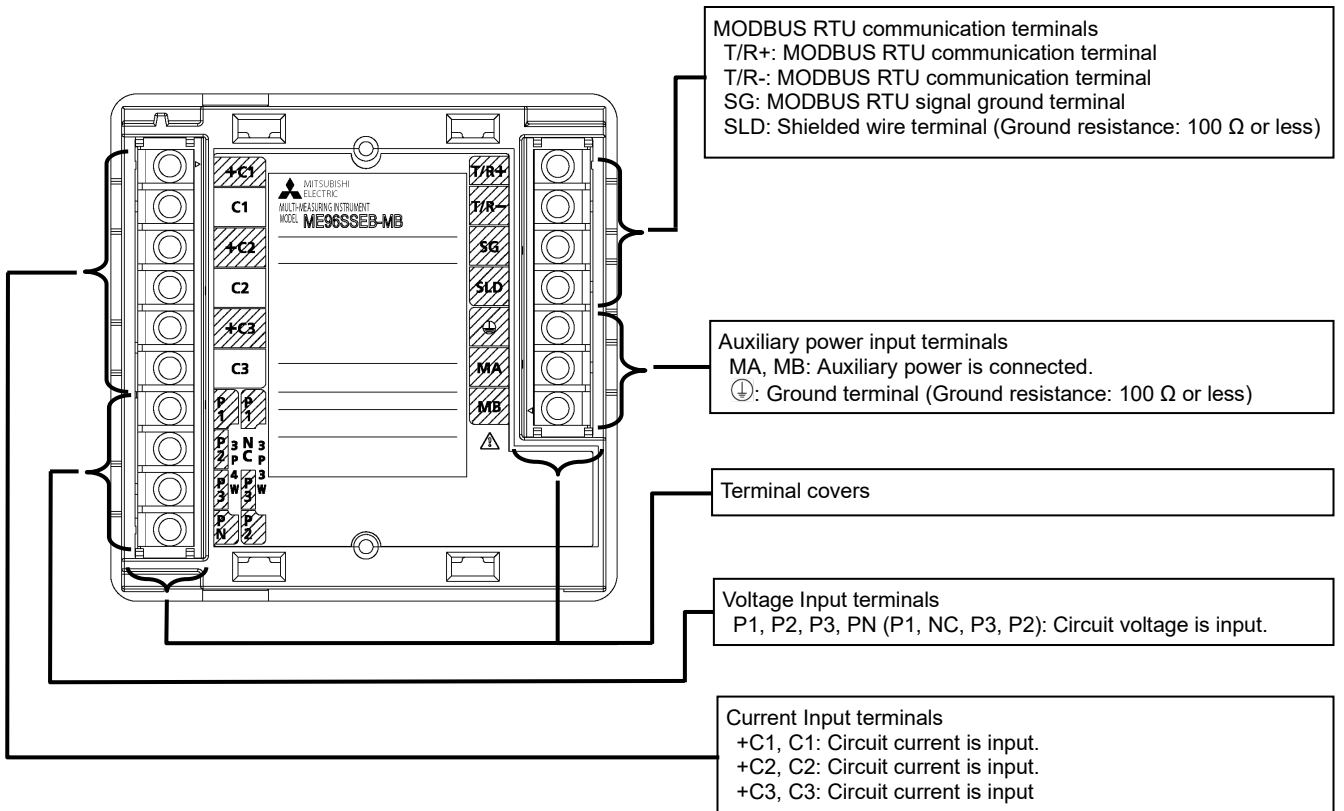

1. Name and Function of Each Section

1.2. LCD Function

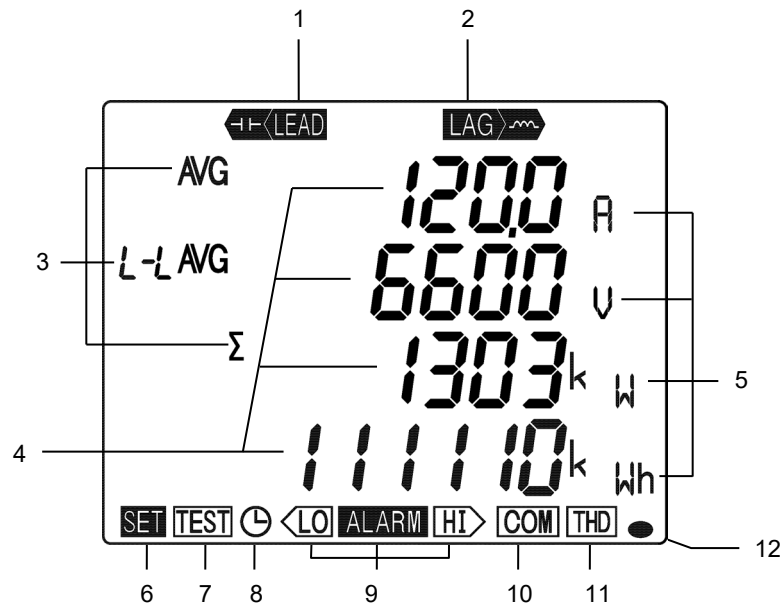

Note: The above display is an example for explanation.

No.	Name of each part	Function								
1	LEAD display	Light up on the reactive energy (imported lead)/ (exported lead) screen.								
2	LAG display	Light up on the reactive energy (imported lag)/ (exported lag) screen.								
3	Digital element display	Display measuring elements expressed in digital numbers								
4	Digital display	Display measured values in digital numbers								
5	Unit	Display the units of measured values								
6	Setup status	Light up in the setting mode Blink in the setting confirmation mode								
7	Test mode status	Light up in the test mode								
8	Clock status	Light up when operating time is displayed								
9	Upper/lower limit alarm status	Blink when the upper/lower limit alarm is generating								
10	Communication status	<table border="1"> <thead> <tr> <th>Specification</th> <th>ON</th> <th>Blink</th> <th>OFF</th> </tr> </thead> <tbody> <tr> <td>MODBUS RTU communication</td> <td>Normal</td> <td>Communication error such as wrong address *1</td> <td>Hardware error</td> </tr> </tbody> </table>	Specification	ON	Blink	OFF	MODBUS RTU communication	Normal	Communication error such as wrong address *1	Hardware error
		Specification	ON	Blink	OFF					
MODBUS RTU communication	Normal	Communication error such as wrong address *1	Hardware error							
*1. For details, refer to 6.5 Troubleshooting .										
11	Harmonics	Light up when harmonic is displayed								
12	Metering status	Blink when imported active energy is measured *Note 1 *It appears on the active energy (imported) screen only.								

Note 1: The blinking cycle is constant regardless of measuring input size.

1. Name and Function of Each Section

1.3. Function of Operation Buttons

The function of each operation button varies depending on how to press the button.

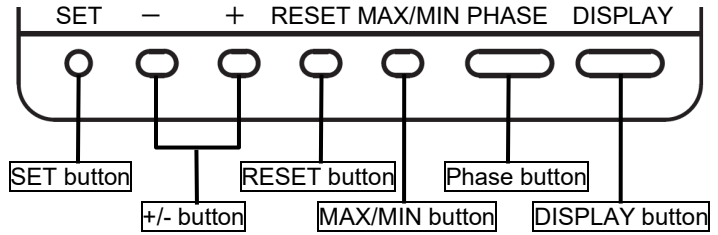

<Meaning of marks>

○: Press, □: Press for 1 second or more, ⊙: Press for 2 seconds or more, —: Press simultaneously

Operation Mode	Button name							Function				
	SET	-	+	RESET	MAX/MIN	PHASE	DISPLAY					
Operating mode	Display switching							○	Switch the measurement screen.			
			○ —						○	Switch the measurement screen in the reverse direction.		
								○		Switch phase display.		
										○	Switch between the harmonic RMS value and distortion ratio on the harmonics display screen.	
							○				Enter/Exit the Max/Min value screen.	
									⊙		Enter the cyclic display mode for measurement screen. Refer to 5.1.3.	
	Measured value clearness/Alarm reset									⊙	Enter the cyclic display mode for phase. Refer to 5.1.3.	
											⊙	Switch between the harmonic RMS value and distortion ratio in cyclic mode on the harmonics display screen.
			⊙ — ⊙									Change the units such as Wh, varh, and VAh or display the lower-digit enlarged view. Refer to 5.1.9.
						⊙						Clear the maximum and minimum values displayed on the screen.
						⊙ — ⊙						Clear maximum and minimum values for every item in every screen.
						⊙ — ⊙ — ⊙						Reset Wh, varh, and VAh to zero. All measured values are reset to zero simultaneously.
	Mode switch									⊙	Reset operating time to zero. (The operating time displayed on the screen only)	
						○					○	Reset the alarm displayed on the screen.
						⊙						Reset all alarms at once. (For every item in every screen)
						○						Stop the backlight blinking caused by alarm only when set to backlight blinking.
			⊙ — ⊙									Enter the setting mode.
			⊙									Enter the setting confirmation mode.
Setting confirmation mode	Setting operation								⊙ — ⊙		Enter the password protection screen.	
		○									Determine the settings and then shift to the next settings.	
									○			Return to the previous setting item.
			○	□								Round up/down the setting value. Pressing for 1 second or more enables fast forward.
			□		□							Skip the settings and return to the setting menu screen.
	○										Reflect the setting change on the END screen.	
	○										Cancel the setting change on the CANCEL screen.	
Special operation									□ — □		Restart the instrument on the CANCEL screen.	
									⊙ — ⊙		Initialize to the factory default settings on the CANCEL screen. Refer to 3.12.	

Note: During backlight off mode, pressing any operation button first turns on the backlight. In addition, pressing any button again enables the use of the functions in the above table.

1. Name and Function of Each Section

1.3. Function of Operation Buttons



- When you execute a function such as 'Reset Max/Min value' or 'Reset Wh, varh, and VAh to zero', past data is deleted. If you need to keep the data, record the data before the reset operation.
- When you execute 'Restart the instrument', the entire measurement function (measurement display, communication) will stop for a few seconds.

2. Each Mode Function

The instrument has the following operation modes.

When auxiliary power is supplied, the operating mode is first displayed.

Depending on the application, switch the operation mode to use.

Mode	Description	Reference
Operating mode	This is a normal operation mode to display each measured value in digital numerical number. In the operating mode, there are 'Present value display' that shows values at present and 'Max/Min value display' that shows maximum and minimum values in the past. In addition, on each display screen, the cyclic display mode, which automatically switches the display screen every 5 seconds, is available.	5 Operation
Setting mode	This is a mode where you can change the settings for measurement function. In addition, on the CANCEL screen, which is the screen to cancel the setting change, the following special operations are available. <ul style="list-style-type: none"> Restart the instrument. Reset the settings to the factory default. 	3 How to Set up
Setting confirmation mode (Test mode)	This is a mode where you can confirm the setting of each item. In this mode, you cannot change the settings. Therefore, it is possible to prevent from accidentally changing the settings. The mode provides test function available at startup of systems. <ul style="list-style-type: none"> Communication Test: Without measurement input (voltage/current), fixed numerical data can be returned. Support function for checking input wiring: When either a voltage input or current input is incorrectly wired, the incorrect wiring part is displayed on the screen. In addition, useful information is also displayed such as a current phase angle and voltage phase angle. 	3.10 or 4 How to Use Test Mode

■ Flow of each mode

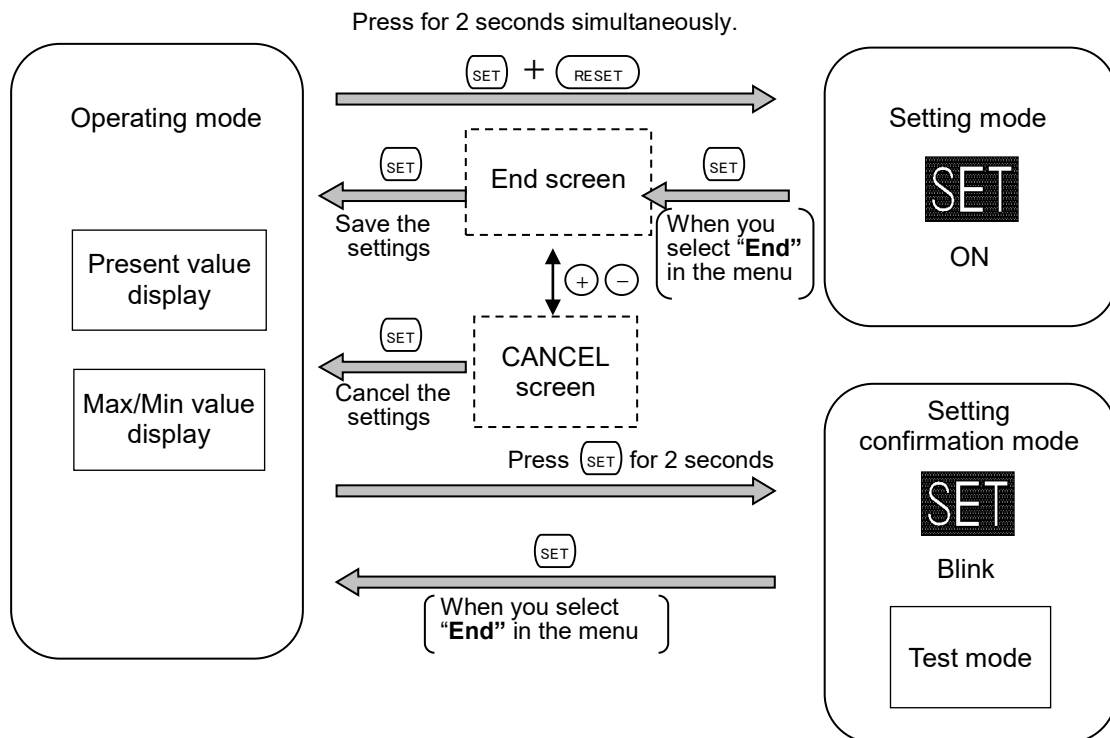

3. How to Set up

3.1. Setting Flow

For measurement, you must set settings such as phase wire system, VT/Direct voltage, and CT primary current in the setting mode.

From the operating mode, enter the setting mode and then set necessary items. Any items not set remain in the factory default settings.

For normal use, only set up the items in the setting menu 1. For details on the settings, refer to 3.2.

For details on the factory default settings, refer to 8.4.

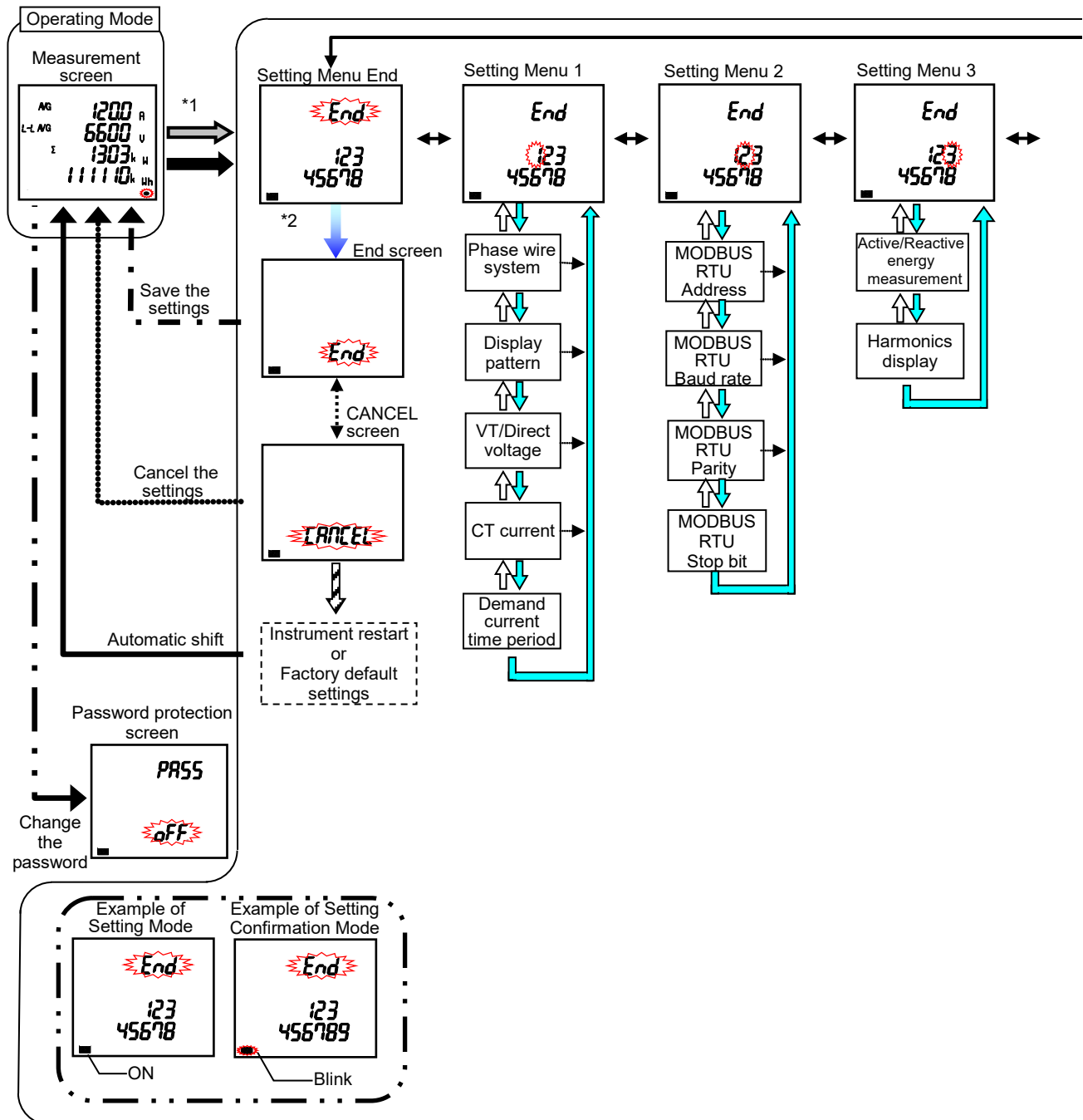

The setting change provides the initialization of the related setting items and measured data. Therefore, check that beforehand. For details, refer to 3.11 **Initialization of Related Items by Changing a Setting.**

3. How to Set up

3.1. Setting Flow

<Setting Procedure>

- (1) Press the **(SET)** and **(RESET)** buttons simultaneously for 2 seconds to enter the setting mode.
- (2) Select the setting menu number with the **(+)** or **(-)** button.
- (3) Press the **(SET)** button to determine the setting menu number.
- (4) Set each setting item. (Refer to 3.2 to 3.9.)
- (5) After completing all the settings, select **End** in the setting menu and then press the **(SET)** button.
- (6) When the **End** screen appears, press the **(SET)** button again.

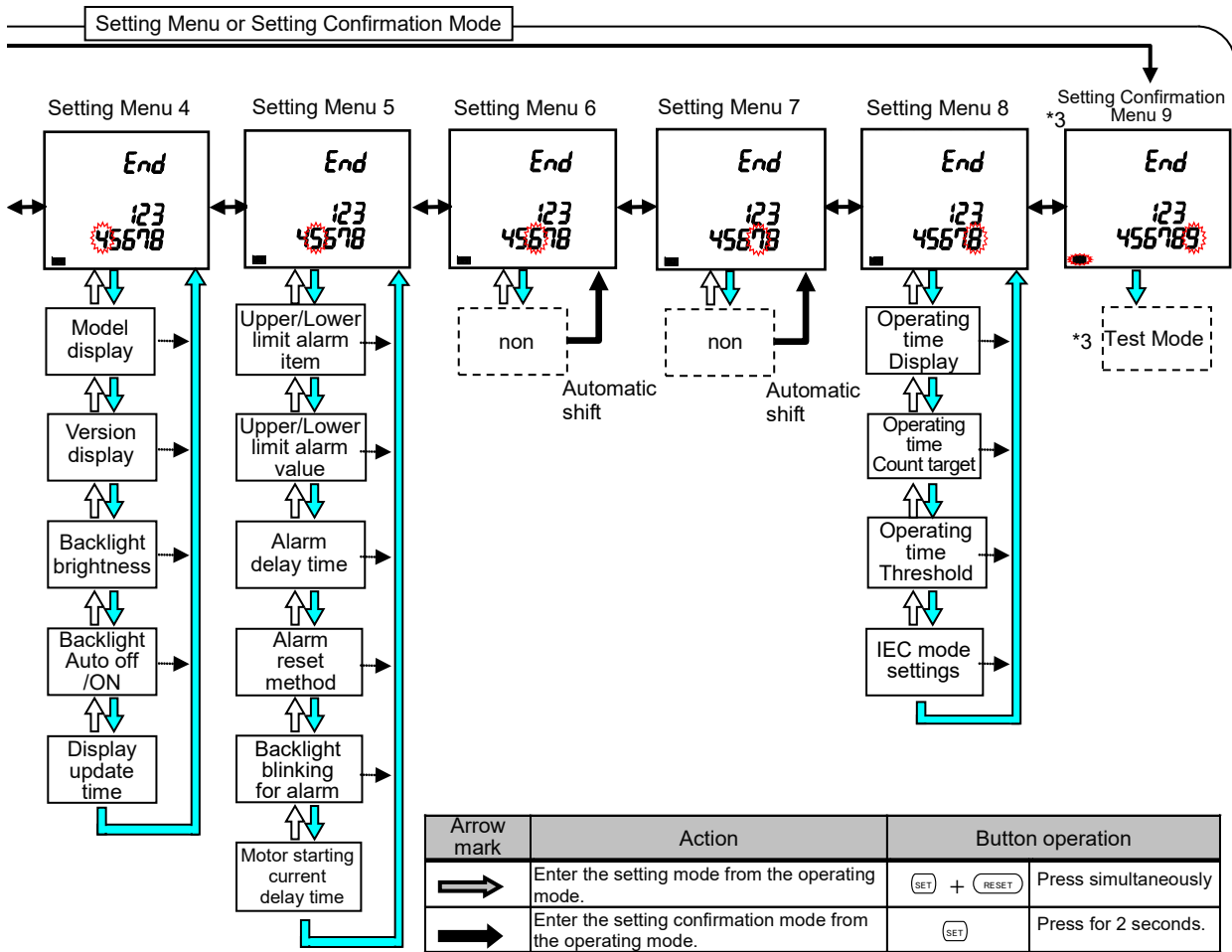

Arrow mark	Action	Button operation	
	Enter the setting mode from the operating mode.	(SET) + (RESET)	Press simultaneously
	Enter the setting confirmation mode from the operating mode.	(SET)	Press for 2 seconds.
	Select the menu number to set up or End .	(+) or (-)	Press several times.
	Enter the setting screen. Shift to the next setting item.	(SET)	Press
	Return to the previous setting item.	(DISPLAY)	Press
Omitted	Select a set value.	(+) or (-)	Press several times.
	Shift to the End screen.	(SET)	Press
	Save the settings and then return to the operating mode.	(SET)	Press
	Select CANCEL .	(+) or (-)	Press
	Cancel the settings.	(SET)	Press
	Skip the current settings during setup.	(SET)	Press for 1 second
	Reset the settings to the factory default settings.	(RESET) + (PHASE)	Press for 2 seconds
	Enter the password protection screen from the operating mode.	(RESET) + (PHASE)	Press for 2 seconds

*1: If you enable password protection, you need to input the password to enter the setting mode from the operating mode.

*2: In the setting confirmation mode, the screen returns to the operating mode.

*3: This is not displayed in the setting mode.

3. How to Set up

3.1. Setting Flow

■ Basic operation for settings

The following table shows a list of basic operations for settings.

Function	Operation	Note
Select a setting	Press \oplus or \ominus button	Fast-forward by pressing for 1 second or more
Determine a setting	Press SET button	When the setting is determined, the screen will shift to the next setting item.
Return to the previous setting item	Press DISPLAY button	The setting before return is enabled.
Return to the setting menu during setup	Press SET button for 1 second	

3. How to Set up

3.2. Setting Menu 1: Basic Setup (Settings for Phase Wire System, Display Pattern, VT/Direct Voltage, and CT Primary Current)

You will set the phase wire system, display pattern, VT/Direct voltage, CT primary current, and demand time period.

In the operating mode, press the **SET** and **RESET** buttons simultaneously for 2 seconds or more to enter the following operation.

Setting Menu

↑

DISPLAY

↓

SET

Select 1 in the setting menu.
*Refer to the right figure.

End



①Phase wire system

↑

DISPLAY

↓

SET

Set the phase wire system according to the measurement target circuit.

3P4: 3-phase 4-wire

3P3. 2CT: 3-phase 3-wire (2CT)

3P3. 3CT: 3-phase 3-wire (3CT)

1P3. 1N2: 1-phase 3-wire (1N2 display)

1P3. 1N3: 1-phase 3-wire (1N3 display)

1P2: 1-phase 2-wire

Note: The underlined shows the default setting.
(The same as below)

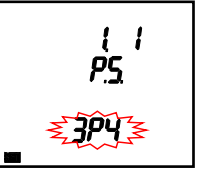

②Display Pattern

↑

DISPLAY

↓

SET

Set the display pattern.

← P01 ↔ P02 ↔ P00 ←

<When 1-phase 2-wire is set at
①Phase wire system.>

P02 is not selectable.

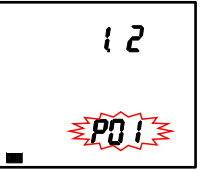

The following table shows measuring elements displayed on each display pattern. The measuring elements displayed on P01 and P02 are the same. For P01, four elements are displayed in one screen. For P02, each phase is displayed in one screen. For details, refer to 6.1.

P00 is a special display pattern to freely set display items. For details on the settings, refer to 3.13.

○: Displayable only by this setting
△: Other additional settings are necessary to display.
□: Select 'P00' and set up the display order and position.

1) When set to 3-phase 4-wire system

Display Pattern	Current	N phase current	Current demand	N phase current demand	Voltage	Active power	Reactive power	Apparent power	Power factor	Frequency	Active energy (imported)	Reactive energy	Apparent energy	Additional Screen *Note				
														Active energy (imported/exported)	Reactive energy	Apparent energy	Harmonic current/voltage	Operating time
P01	○	○	○	○	○	○	○	○	○	○	○	○	○	○	△	△		
P02	○	○	○	○	○	○	○	○	○	○	○	○	○	○	△	△		
P00	□	□	□	□	□	□	□	□	□	□	□	□	□	△	△	△		

Continued to the next page.

3. How to Set up

3.2 Setting Menu 1: Basic Setup (Settings for Phase Wire System, Display Pattern, VT/Direct Voltage, and CT Primary Current)

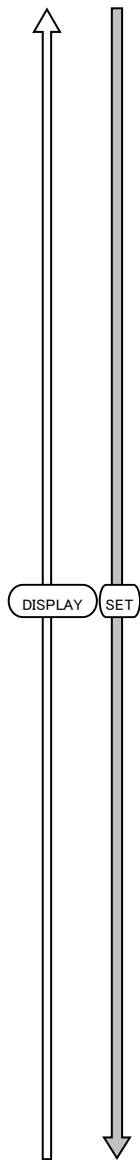

Continued from the previous page.

(2) For measurement with VT

<Secondary voltage setting>

(a) When set to 3-phase 4-wire system (Phase voltage)

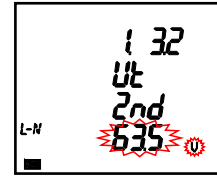
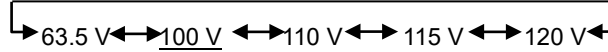

(b) When set to 3-phase 3-wire (2CT, 3CT) /1-phase 2-wire (Line voltage)

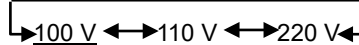

<Primary voltage setting>

The factory default settings:

- For 3-phase 4-wire system ⇒ 200 V (Phase voltage)
- For 3-phase 3-wire/1-phase 2-wire system ⇒ 10000 V (Line voltage)

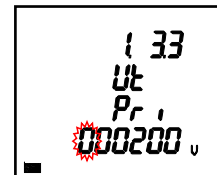

- From the upper digit, set the blinking digit with (+) or (-).
- By pressing (SET), move the setting digit, blinking one, to a lower digit.
- By pressing (DISPLAY), move the setting digit, blinking one, to an upper digit.
- The setting ranges from 60 V to 750000 V. The setting unit is V.
 - *If you set out of range, the error message (E05) will appear. If the error message appears, press (SET) and then review the settings to set it again.
- By pressing (SET) at the lowest digit, shift to the next setting item.

Set the settings for CT.

You will set the primary and secondary current of CT.

<Secondary current setting>

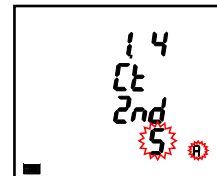
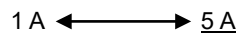

Note: CT is Current Transformer.

<Primary current setting>

The factory default setting: 5.0 A

- From the upper digit, set the blinking digit with (+) or (-).
- By pressing (SET), move the setting digit, blinking one, to a lower digit.
- By pressing (DISPLAY), move the setting digit, blinking one, to an upper digit.
- The setting ranges from 1.0 A to 30000.0 A. The setting unit is A.
 - *If you set out of range, the error message (E05) will appear. If the error message appears, press (SET) and then review the settings to set it again.
- By pressing (SET) at the lowest digit, shift to the next setting item.

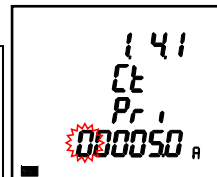

④ CT current

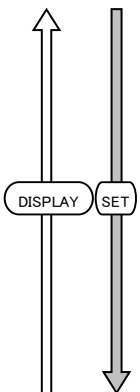

3. How to Set up

3.2 Setting Menu 1: Basic Setup (Settings for Phase Wire System, Display Pattern, VT/Direct Voltage, and CT Primary Current)

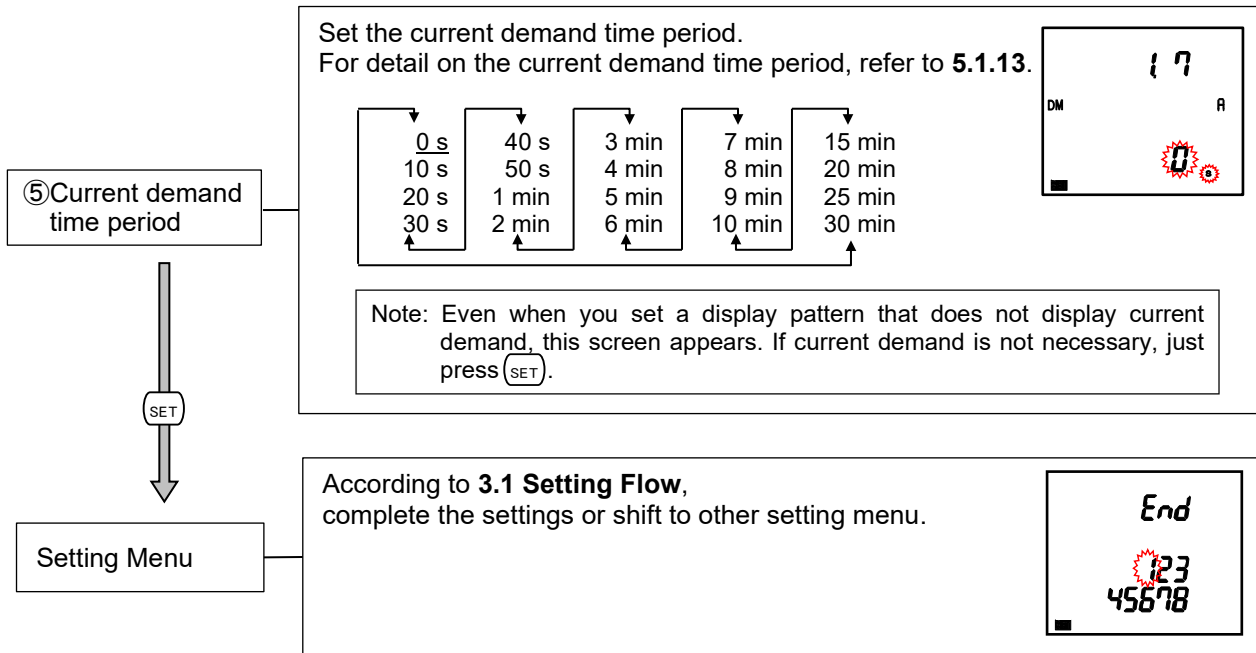

If only the settings in the setting menu 1 are necessary to use, move to **5 Operation**.
If you use an additional function, set it in the setting menu 2 to 8.

Note	<p>If you change a setting in the setting menu 1, the maximum and minimum values of the related measuring elements will be reset. However, active/reactive energy will not be reset.</p> <p>For details, refer to 3.11 Initialization of Related Items by Changing a Setting.</p>
-------------	--

3. How to Set up

3.3. Setting Menu 2: Communication Settings (MODBUS RTU Communication Settings)

In the operating mode, press the **(SET)** and **(RESET)** buttons simultaneously for 2 seconds or more to enter the following operation.

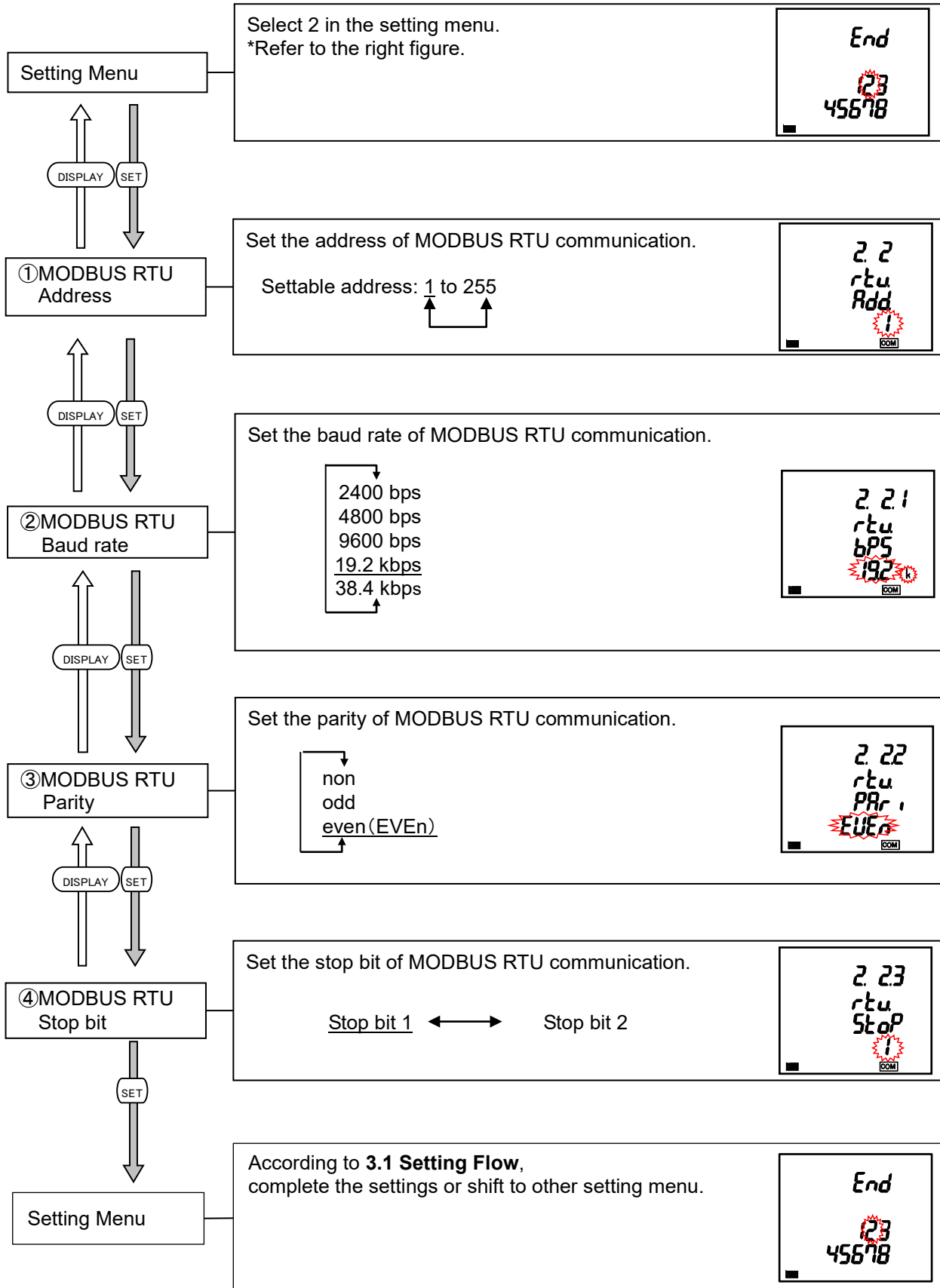

3. How to Set up

3.4. Setting Menu 3: Display Settings (Settings for Display of Active/Reactive Energy and Harmonic Measurement)

This section describes how to set the special measurement of active/reactive energy and harmonic display. In the operating mode, press the **SET** and **RESET** buttons simultaneously for 2 seconds or more to enter the following operation.

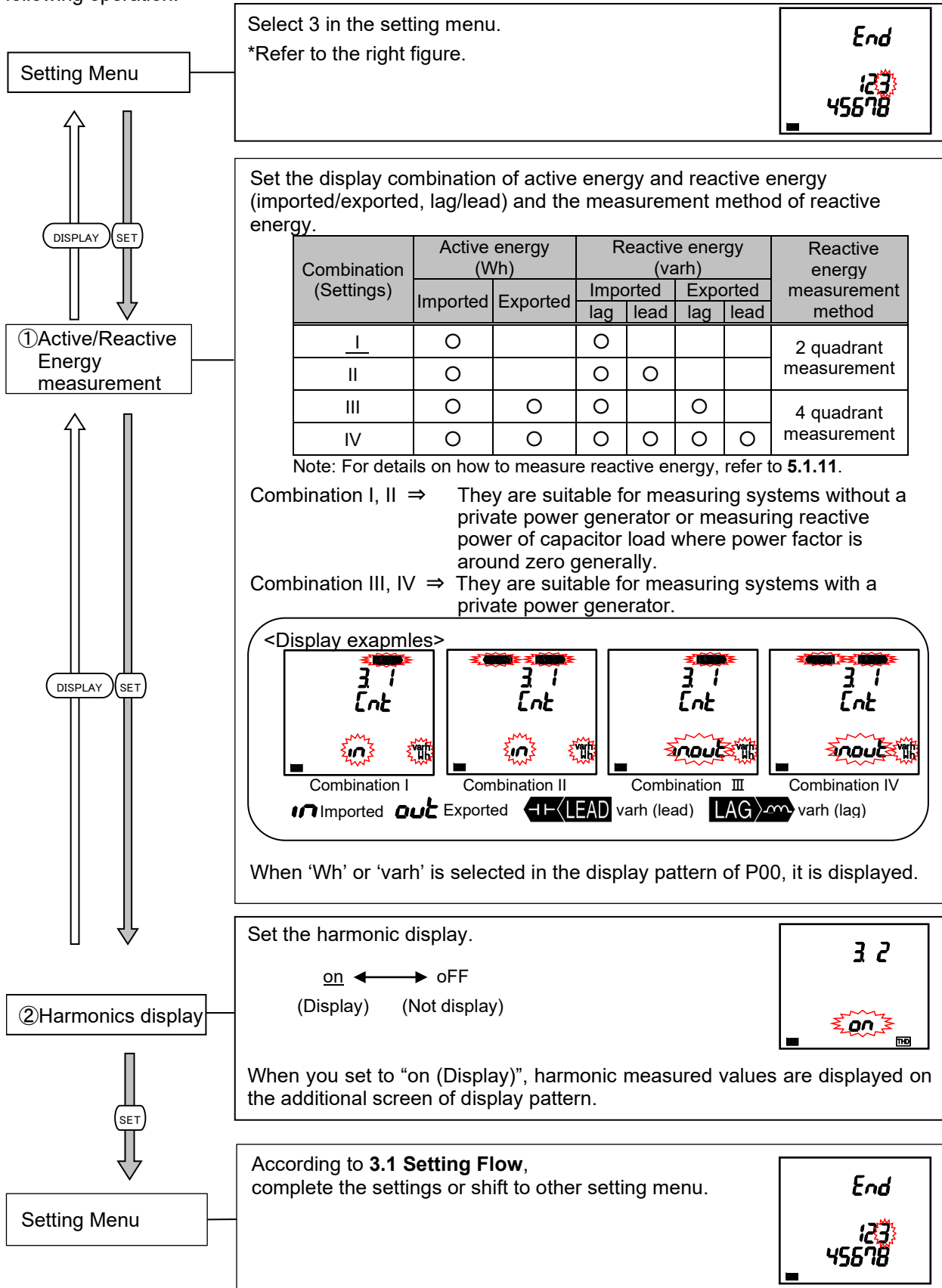

3. How to Set up

3.5. Setting Menu 4: LCD Settings (Settings for Model Display, Version Display, Backlight, and Update Time)

This section describes how to check the model and set the backlight and display update time. These settings are not necessary for normal use. In the operating mode, press the **SET** and **RESET** buttons simultaneously for 2 seconds or more to enter the following operation.

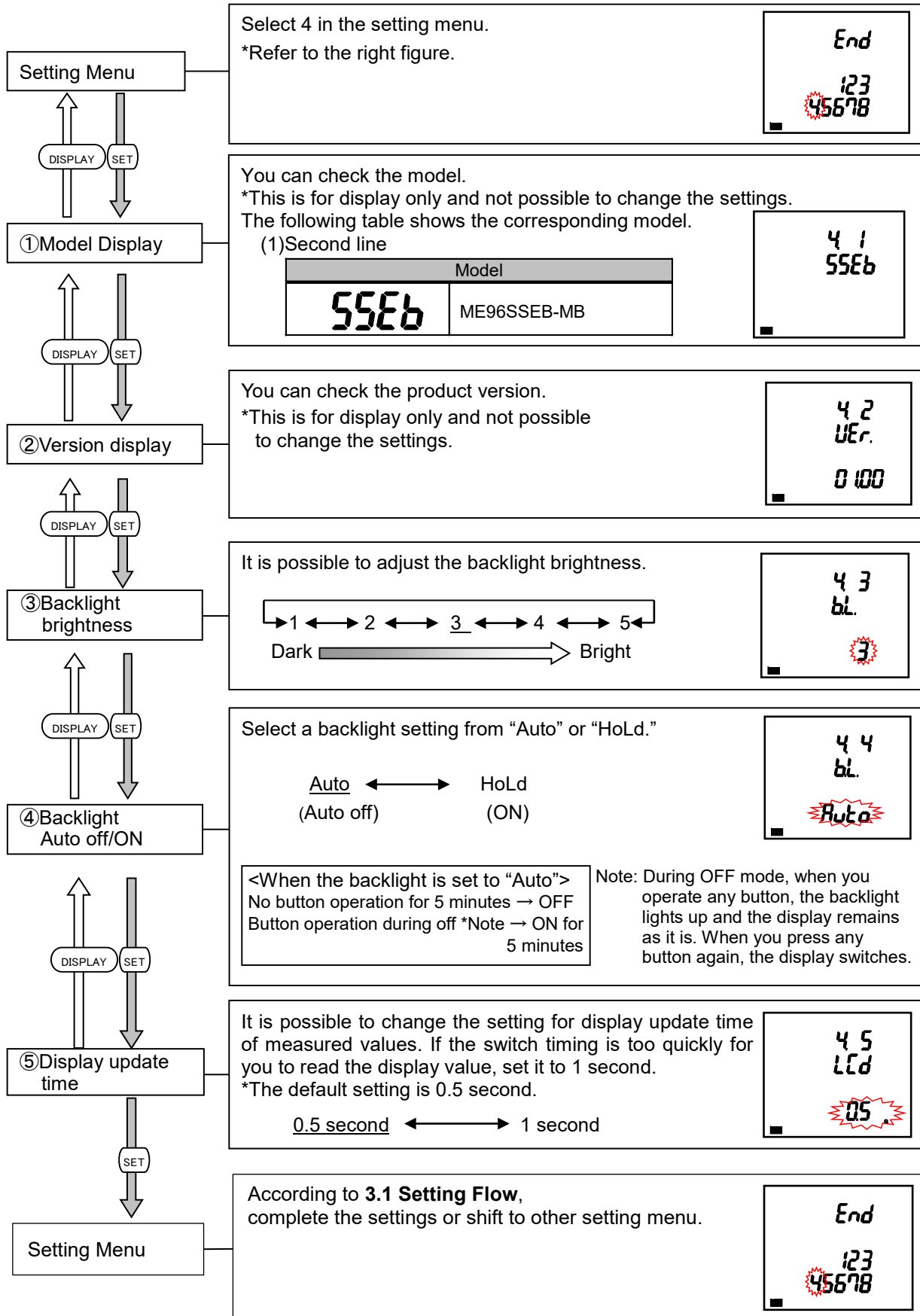

3. How to Set up

3.6. Setting Menu 5: Alarm Settings (Settings for Upper/Lower Limit Alarm and Motor Starting Current Mask Function)

This section describes how to set the upper/lower limit alarm, backlight blinking during alarm, and motor starting current.

In the operating mode, press the **SET** and **RESET** buttons simultaneously for 2 seconds or more to enter the following operation.

- (For details about each function, refer to the following:)
- Upper/lower limit alarm → See 5.2.1 to 5.2.3.
 - Motor starting current → See 5.2.6.

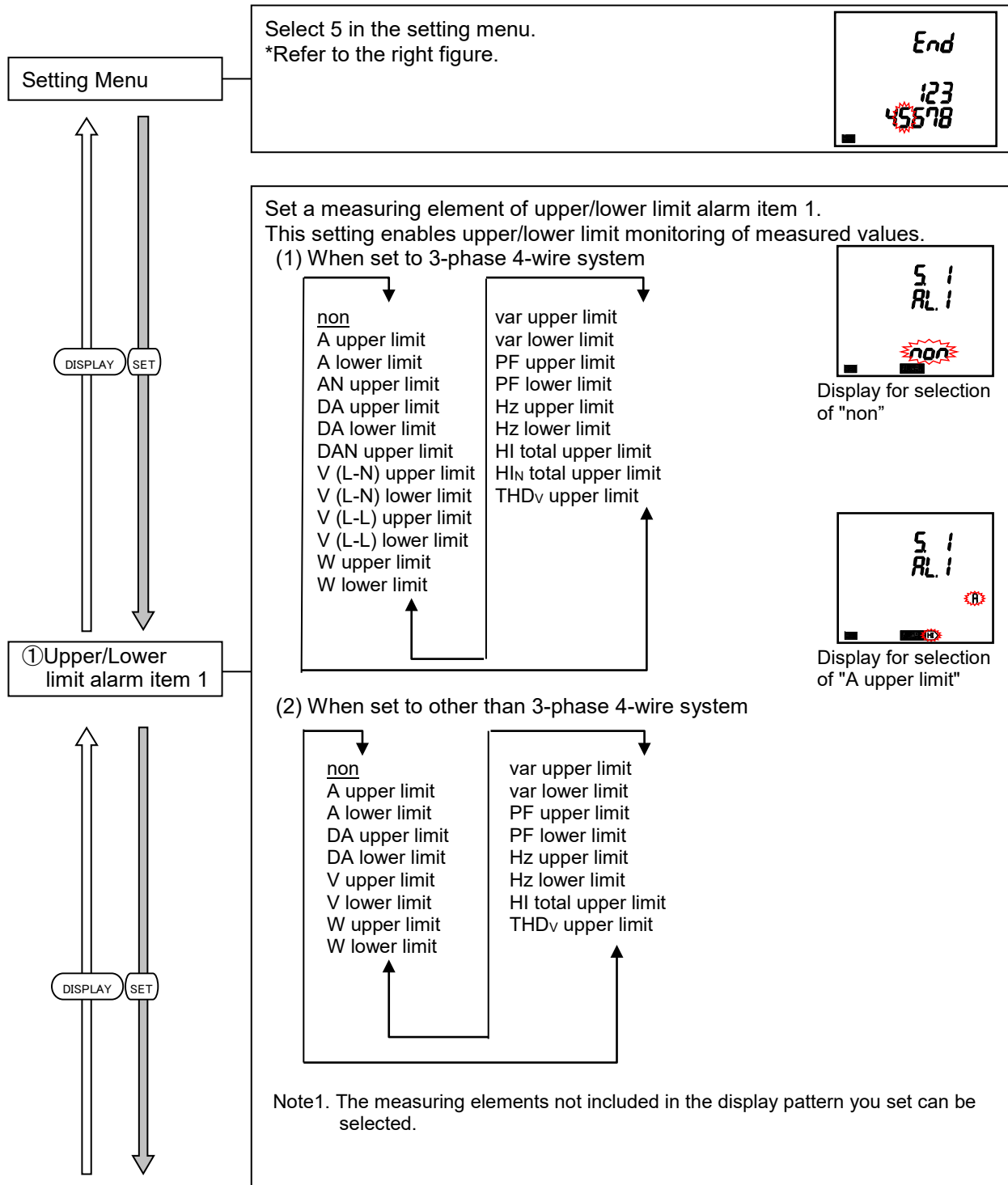

3. How to Set up

3.6 Setting Menu 5: Alarm Settings (Settings for Upper/Lower Limit Alarm and Motor Starting Current Mask Function)

② Upper/Lower limit alarm value 1

↑ ↓
DISPLAY SET

③ Upper/Lower limit alarm item 2 to 4

↑ ↓
DISPLAY SET

④ Upper/Lower limit alarm value 2 to 4

↑ ↓
DISPLAY SET

⑤ Alarm delay time

↑ ↓
DISPLAY SET

⑥ Alarm reset method

↑ ↓
DISPLAY SET

Set the alarm value of upper/lower limit alarm item 1. The following table shows the setting range.

Measuring element	Setting range	Setting Step *Note
A, AN, DA, DAN upper limit	5 to 100 to 120 (%)	1%
A, DA lower limit	3 to 10 to 95 (%)	1%
V (L-N), V (L-L) upper limit	25 to 110 to 135 (%)	1%
V (L-N), V (L-L) lower limit	20 to 70 to 95 (%)	1%
W upper limit, var upper limit	-95 to 100 to 120 (%)	1%
W lower limit, var lower limit	-120 to 3 to 95 (%)	1%
PF upper limit	-0.05 to 1 to 0.05	0.05
PF lower limit	-0.05 to -0.5 to 0.05	0.05
Hz upper limit	45 to 65 (Hz)	1Hz
Hz lower limit	45 to 65 (Hz)	1Hz
HI total upper limit	1 to 35 to 120 (%)	1%
HI _N total upper limit	1 to 35 to 120 (%)	1%
THD _v total upper limit	0.5 to 3.5 to 20.0 (%)	0.5%

Note: W and var show the percentage ratio of a standard value.
 For details about how to calculate the standard value, refer to **6.2 Standard Value**.
 A, AN, DA, DAN, the total RMS value of harmonic current, and the total RMS value of harmonic current N-phase show the percentage ratio of the CT primary current setting.
 V shows the percentage ratio of the VT primary voltage setting (or direct voltage).
 *For 1-phase 3-wire system, V shows the percentage ratio of the phase voltage.
 For 12-phase or 31-phase, alarm monitoring is executed based on twice the set upper/lower limit alarm value.

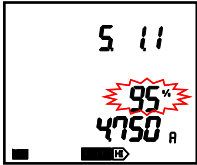

Set a measuring element of each of upper/lower limit alarm item 2 to 4. The item you have already selected is not available repeatedly. The setting method is the same as ① Upper/Lower limit alarm item 1.

Set the alarm value of each of upper/lower limit alarm item 2 to 4. The setting method is the same as ② Upper/Lower limit alarm value 1.

Set the alarm delay time if you want to prevent an alarm caused by momentary overload or noise. If you set this setting, an alarm will occur only when the upper/lower limit alarm value is exceeded and the situation continues for a period of alarm delay time.

0 s	30 s	2 min
5 s	40 s	3 min
10 s	50 s	4 min
20 s	1 min	5 min

Note: When ① Upper/Lower limit alarm item 1 and ③ Upper/Lower limit alarm item 2 to 4 are all set to "non", this setting is skipped.

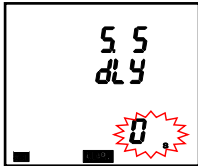

Set the reset method to cancel an alarm.

Reset method (Settings)	Description (For details, refer to 5.2.1 to 5.2.2.)
Automatic (Auto)	When alarm-generating conditions disappear, the alarm is automatically reset.
Manual (HoLd)	Even if alarm-generating conditions disappear, the alarm is retained. To cancel the alarm, you must execute button operation.

Note: When ① Upper/Lower limit alarm item 1 and ③ Upper/Lower limit alarm item 2 to 4 are all set to 'non', this setting is skipped.



3. How to Set up

3.6 Setting Menu 5: Alarm Settings (Settings for Upper/Lower Limit Alarm and Motor Starting Current Mask Function)

⑦ Backlight blinking for alarm

DISPLAY

SET

It is possible to blink the backlight in case of alarm.

oFF ↔ on
(Not blink) (Blink)

Note: When ① Upper/Lower limit alarm item 1 and ③ Upper/Lower limit alarm item 2 to 4 are all set to "non", this setting is skipped.

⑧ Motor starting current delay time

DISPLAY

SET

For motor current monitoring, this setting enables to prevent unnecessary maximum value update and alarm generating caused by motor starting current.

- When this setting is not necessary ⇒ Select "oFF" and then press SET to move to the next setting item.
- When this setting is necessary ⇒ Select "on" and then press SET to move to (1) below.

oFF ↔ on

(1) Motor starting current threshold
Set the threshold to detect motor starting current.

Setting range	Setting step *Note
3 to <u>5</u> to 120 (%)	1%

*Note: This is the percentage of the CT primary current setting.

DISPLAY

SET

(2) Motor starting current delay time
During the delay time after motor starting current is detected, neither a maximum value update nor an alarm is generated.

1 s	15 s	1 min	4 min
3 s	20 s	1.5 min	5 min
5 s	30 s	2 min	
<u>10 s</u>	45 s	3 min	

Setting Menu

DISPLAY

SET

According to 3.1 Setting Flow, complete the settings or shift to other setting menu.

3. How to Set up

3.7. Setting Menu 6: No Settings

This setting item is not displayed because there is no corresponding function in this model.

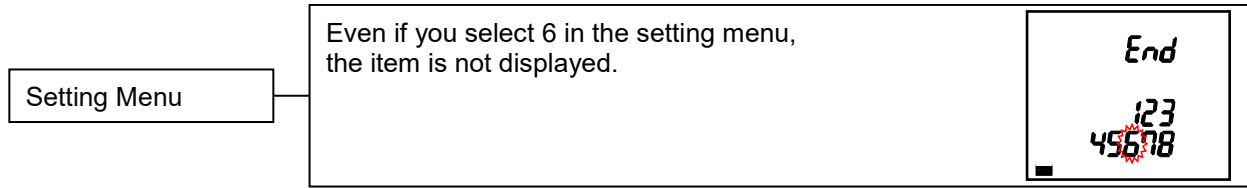

3.8. Setting Menu 7: No Settings

This setting item is not displayed because there is no corresponding function in this model.

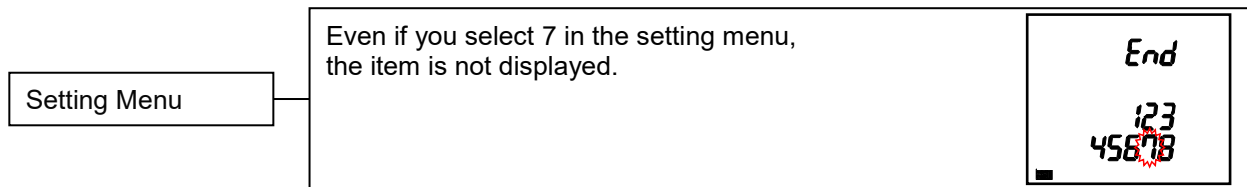

3. How to Set up

3.9. Setting Menu 8: Special Settings (Settings for Operating Time and IEC Mode)

This section describes the settings of the operating time and IEC mode.

In the operating mode, press the (SET) and (RESET) buttons simultaneously for 2 seconds or more to enter the following operation.

For details about each function, refer to the corresponding section.
 Operating time ⇒ See 5.2.4 to 5.2.5.

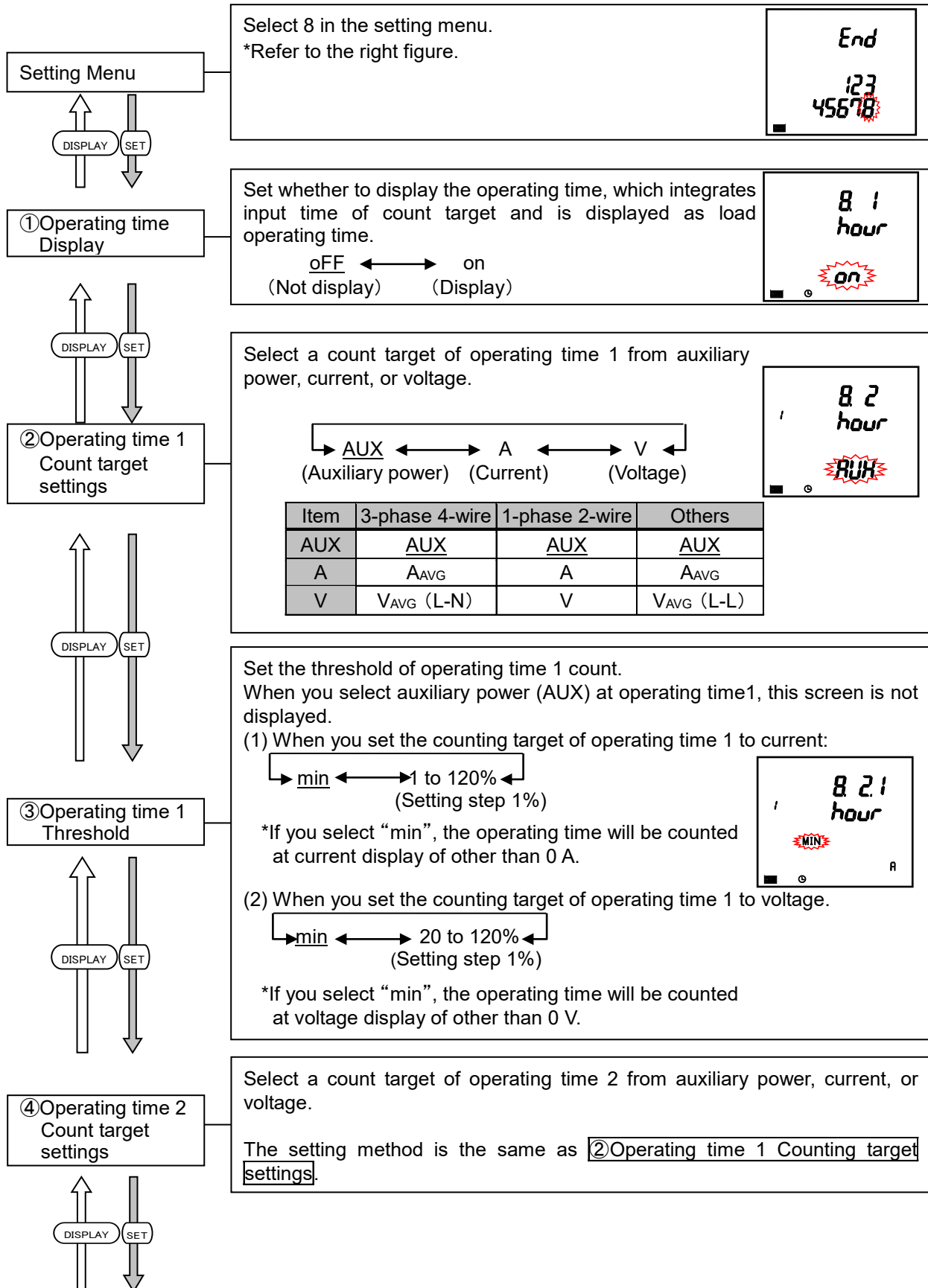

3. How to Set up

3.9. Setting Menu 8: Special Settings (Settings for Operating Time and IEC Mode)

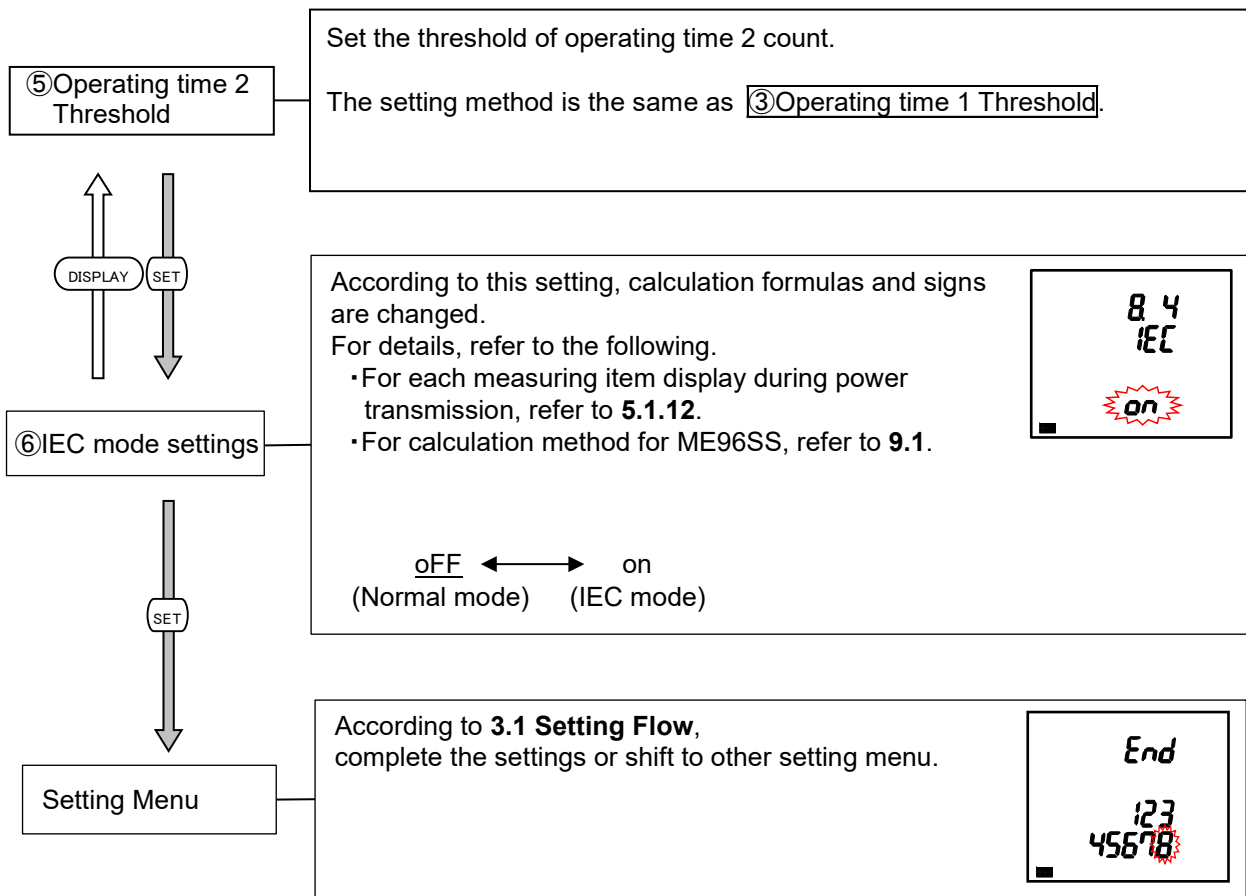

3. How to Set up

3.10. Setting Confirmation Menu 1 to 9: How to Confirm the Settings in the Setting Menu 1 to 8, 9 Test Mode

1. Setting Confirmation

In the operating mode, press **(SET)** for 2 seconds or more to execute the operation.

Setting confirmation menu

In the setting confirmation menu, the screen switching and operation methods are the same as the setting menu 1 to 8. For details, refer to each setting menu.

Note: In the setting confirmation mode, setting change is not possible.



2. Test Mode

In the operating mode, press **(SET)** for 2 seconds or more and then set the setting confirmation menu number to '9' to enter the test mode.

For details on how to use the test mode, refer to **4 How to Use Test Mode**.

3. How to Set up

3.11. Initialization of Related Items by Changing a Setting

When you change a setting, the related setting items and measured data (maximum and minimum values) will be initialized. For details, refer to the following table.

Setting item to be changed			Menu 1				Menu 5	Menu 8	
			Phase wire system *Note	VT/Direct voltage	CT current		Upper/Lower limit alarm item	Operating time 1 count target	Operating time 2 count target
Initialized item			CT secondary current	CT primary current					
Setting item	Menu 1	Phase wire system							
		Display pattern	●						
		VT/Direct voltage	○						
	Menu 5	Upper/Lower limit alarm item	●						
		Upper/Lower limit alarm value	●			●			
	Menu 8	Threshold of Operating time 1 count target					●		
Threshold of Operating time 2 count target							●		
Measuring value		Current, Maximum/Minimum value	●		●	●			
		Current demand, Maximum/Minimum value	●		●	●			
		Voltage, Maximum/Minimum value	●	●					
		Active power, Maximum/Minimum value	●	●	●	●			
		Reactive power, Maximum/Minimum value	●	●	●	●			●
		Apparent power, Maximum/Minimum value	●	●	●	●			●
		Power factor, Maximum/Minimum value	●	●	●	●			●
		Frequency, Maximum/Minimum value	●						
		Harmonic current, Maximum value	●		●	●			
		Harmonic voltage, Maximum value	●	●					

●: It turns to the default setting.

○: It turns to the default setting according to the phase wire system.

Note: For 1-phase 3-wire system, the setting change between '1N2 display' and '1N3 display' does not cause initialization.

3.12. Initialization of All Settings

The following operation enables to reset all settings to the factory default. It is only for the settings. Measured active energy, reactive energy, and operating time are not changed.

For details on the initialization of maximum and minimum values, refer to **3.11 Initialization of Related Items by Changing a Setting**.

*For example, if the phase wire system is changed by initializing all settings, all maximum and minimum values will be reset.

To initialize all settings, display the CANCEL screen in the setting mode and then execute the following operation.

For details on how to display the CANCEL screen, refer to **3.1 Setting Flow**.

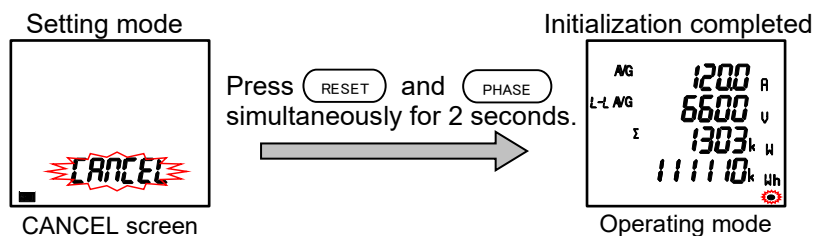

3. How to Set up

3.13. Settings for Special Display Pattern P00

If you want to set a display pattern other than P01 or P02, P00 is available to freely set display items. This setting is conducted in the setting menu 1. The explanation here begins with the settings for P00 at **②Display pattern** in the setting menu 1. For other operations, which are not explained here, refer to **3.2**.

(1) A maximum of 16 measuring items in four screens are available.

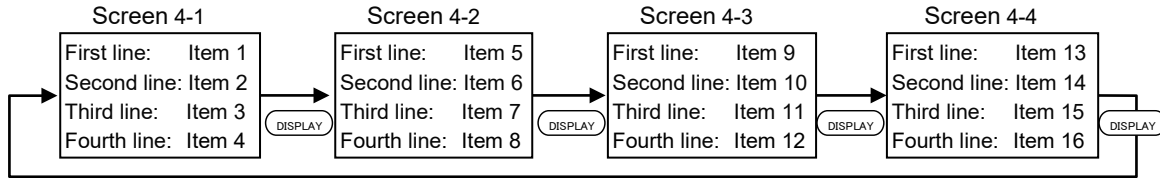

From the first line to the third line, each selectable item is A, DA, V, W, var, VA, PF, or Hz. At the fourth line, Wh, - Wh, varh, and VAh are selectable.

(2) As an example, the following display pattern is used for explanation.

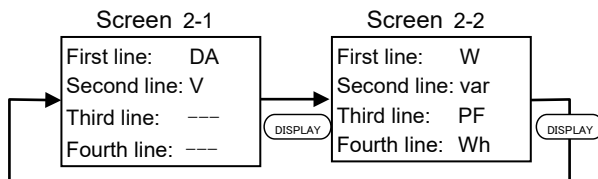

(3) How to set up

②Display pattern

You will set up a display pattern.

- (1) Select "P00."
Select "P00" with \oplus or \ominus and then press **SET**.
- (2) Set the first line to "DM A" in the screen 4-1.
Select "DM A" with \oplus or \ominus and then press **SET**.
- (3) Set the second line to "V" in the screen 4-1.
Select "V" with \oplus or \ominus and then press **SET**.
- (4) Set the third line to no display in the screen 4-1.
Select "----" with \oplus or \ominus and then press **SET**.
- (5) Set the fourth line to no display in the screen 4-1.
Select "----" with \oplus or \ominus and then press **SET**.

3. How to Set up

3.13. Settings for Special Display Pattern P00

Continued from the previous page.

- (6) You will set up the display of screen 4-2.
Select “yES” with \oplus or \ominus and then press SET .

*When the screen 2 is not necessary to display,
select “no” and press SET .

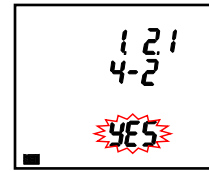

- (7) Set the first line to “W” in the screen 4-2.
Select “W” with \oplus or \ominus and then press SET .

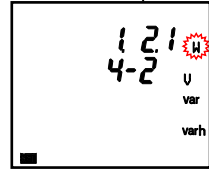

- (8) Set the second line to “var” in the screen 4-2.
Select “var” with \oplus or \ominus and then press SET .

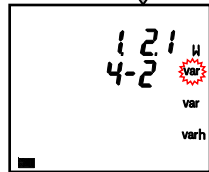

- (9) Set the third line to “PF” in the screen 4-2.
Select “PF” with \oplus or \ominus and then press SET .

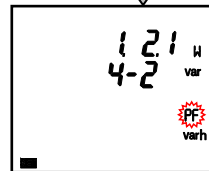

- (10) Set the fourth line to “Wh” in the screen 4-2.
Select “Wh” with \oplus or \ominus and then press SET .

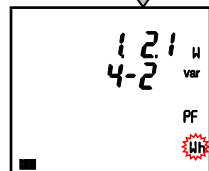

- (11) Set the screen 4-3 to hidden.
Select “no” with \oplus or \ominus and then press SET .

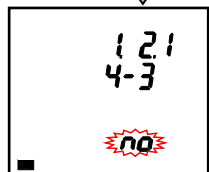

Note: When you set the screen 4-3 to hidden,
the screen 4-4 is automatically set to hidden.

Return to the setting
of the upper line in
the screen 4-1.

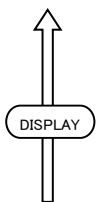

③VT/Direct voltage

(Hereafter same as the setting menu 1)

Note	<ol style="list-style-type: none"> 1. The following measuring items cannot be set in the display pattern of P00. Set them in the setting menu 3 and 8. •Harmonic current, Harmonic voltage, Operating time 2. It is not possible to specify phases of current and voltage. In the operating mode, press PHASE to switch the phase. 3. The following measuring items can be set for 3-phase 4-wire system only. •Current N-phase, Current demand N-phase
-------------	--

3. How to Set up

3.14. Example for Easy Setup

The following example illustrates an easy setup.

■ Setting Example

- Model: ME96SSEB-MB
- Phase wire system: 3-phase 4-wire
- Measuring element: A, V, W, PF
- Input Voltage: 220/380 V
- CT primary current: 200 A
- CT Secondary current: 5 A
- MODBUS RTU: Address: 1, Baud rates: 19.2kbps, Parity: even, Stop bit: 1

■ Setting Procedure

 shows the item where setting change is necessary.

Note: For details on the settings, refer to 3.2.

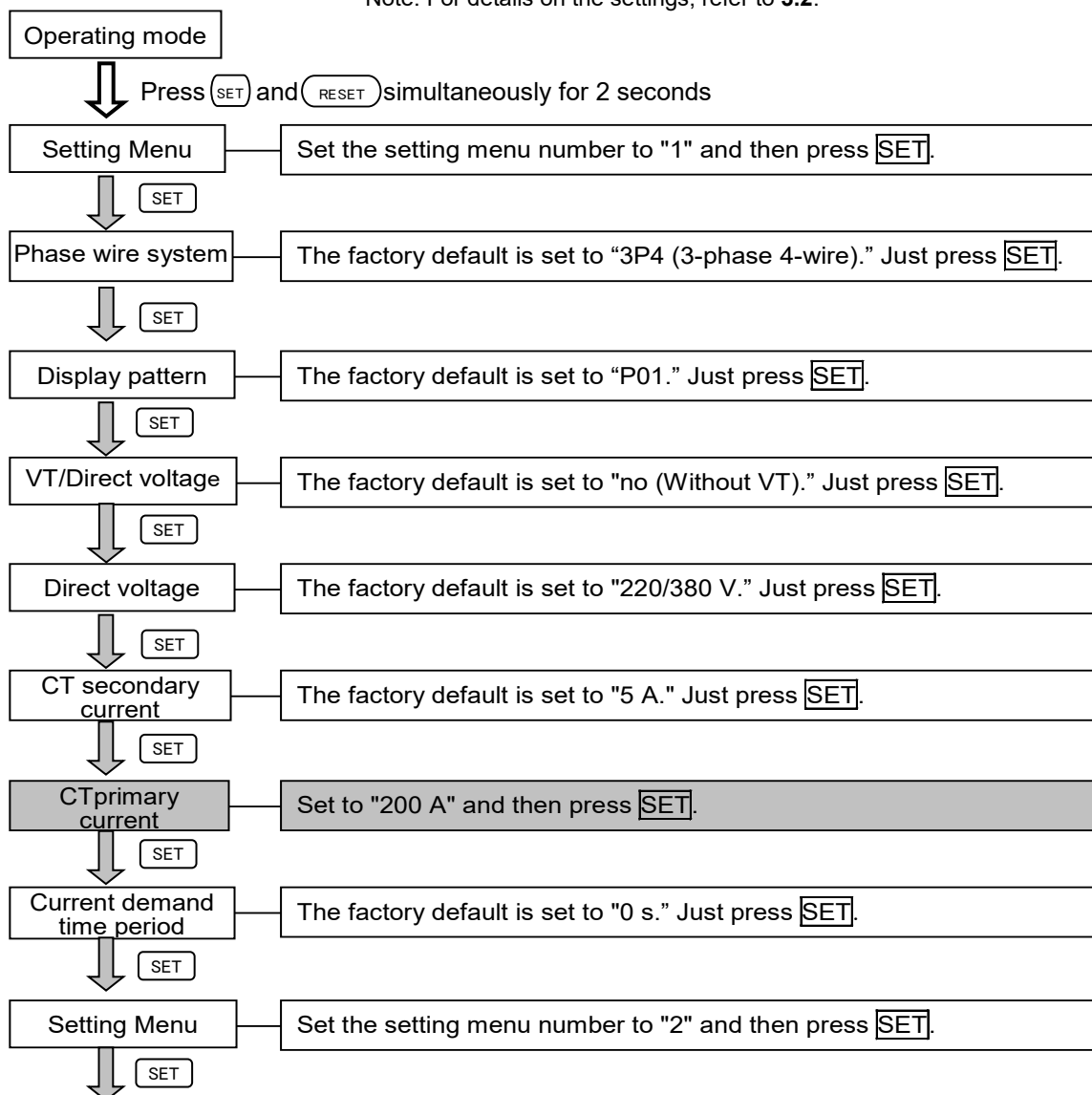

3. How to Set up

3.14. Example for Easy Setup

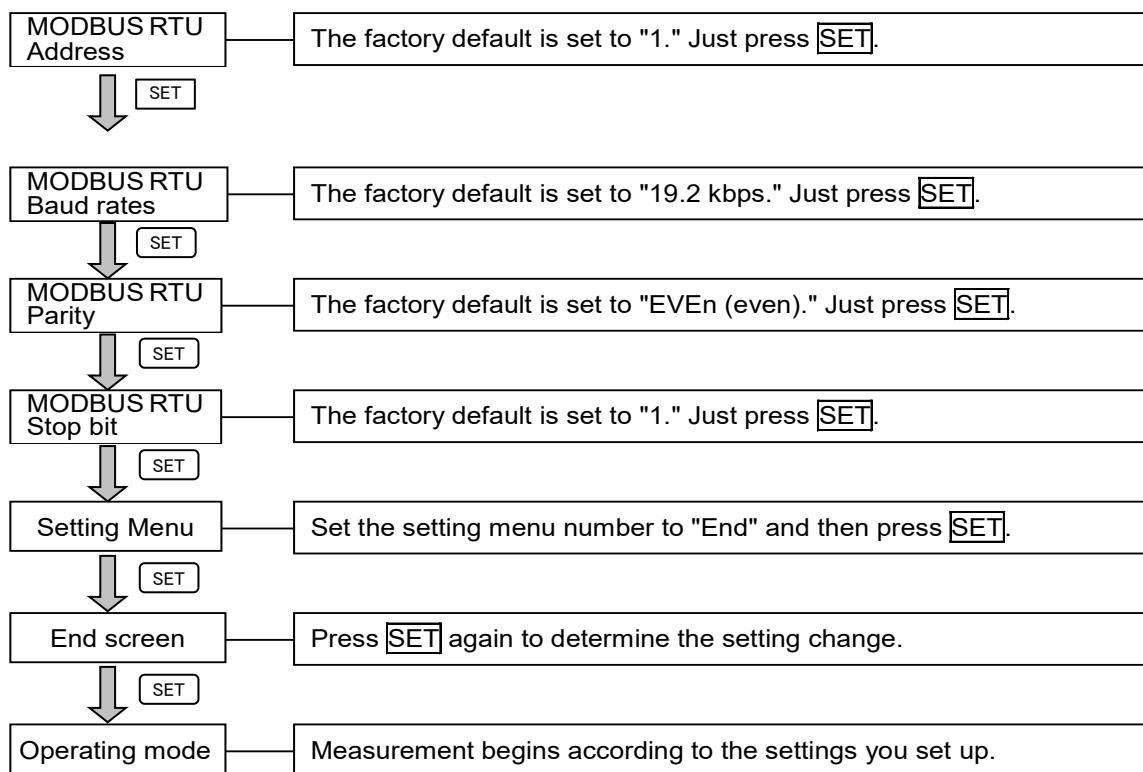

4. How to Use Test Mode

The test mode has function useful for startup of systems.
The following table shows a list of functions in the test mode.

Test menu	Description
1. Communication test	For MODBUS RTU communication function, it is possible to return fixed numerical data without measurement (voltage/current) input. Use this for checking with the host system.
2. to 5. No function	—
6. Functions for determining incorrect wiring	<p>①Pattern display for incorrect wiring When either a voltage input or current input is incorrectly wired, this function automatically determines incorrect wiring and displays its part on the screen. It is easier to find out the incorrect part and useful to check the connection. *Note</p> <p>②Support display for determining incorrect wiring This function displays a current phase angle, a voltage phase angle, and active power, voltage, and current value of each phase. By checking each display and 9.2 A List of Examples for Incorrect Wiring Display, it is easier to determine incorrect wiring for measurement (voltage/current) input.</p>

*Note: The function cannot determine all incorrect wiring. If both a voltage input and a current input are incorrectly wired, a different pattern may be displayed.

■ Test procedure

- ① Press **SET** for 2 seconds to enter the setting confirmation mode.
- ② With **+** or **-**, select '9' in the setting confirmation menu number
- ③ Press **SET** to enter the test mode.
- ④ Execute the test in each test menu. For details, refer to **4 How to Use Test Mode**.

■ Test mode flow

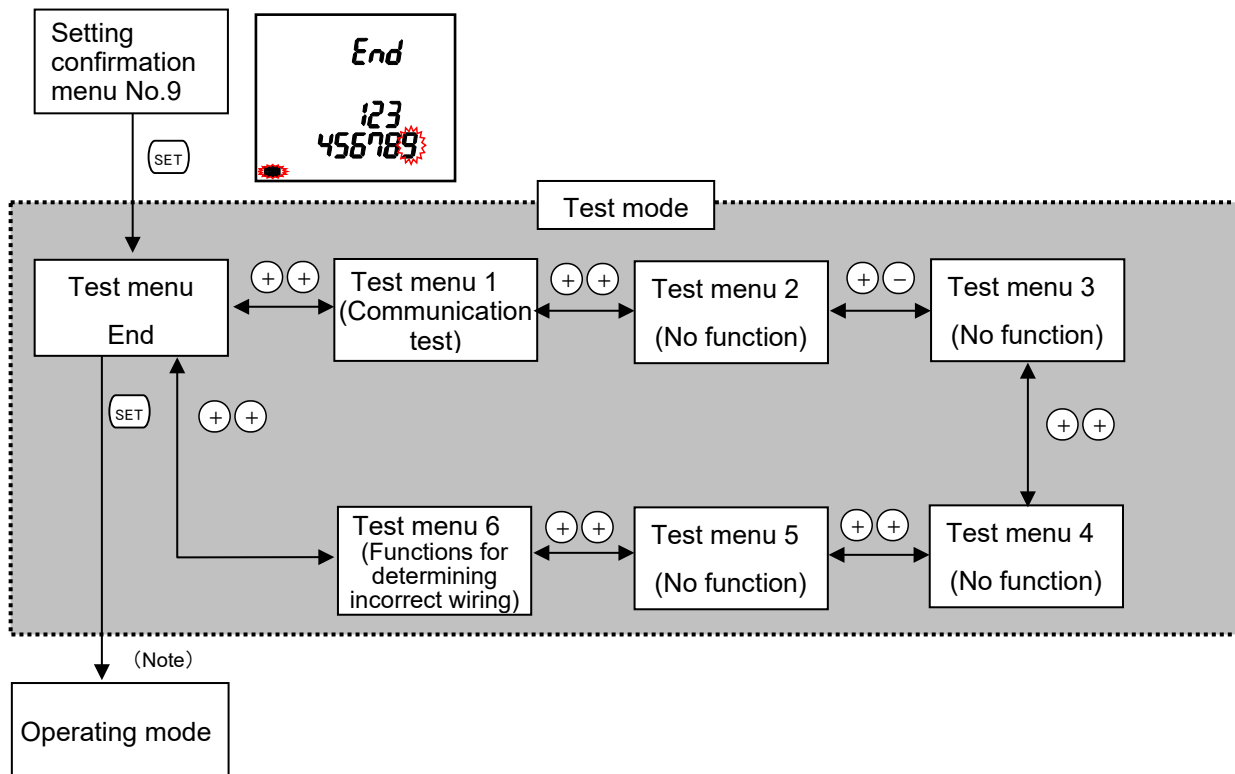

Note: The screen momentarily goes off.

4. How to Use Test Mode

4.1. Test Menu 1: Communication Test

Set the setting confirmation menu number to '9' to enter the test mode
 In the test mode, the following operation is available.

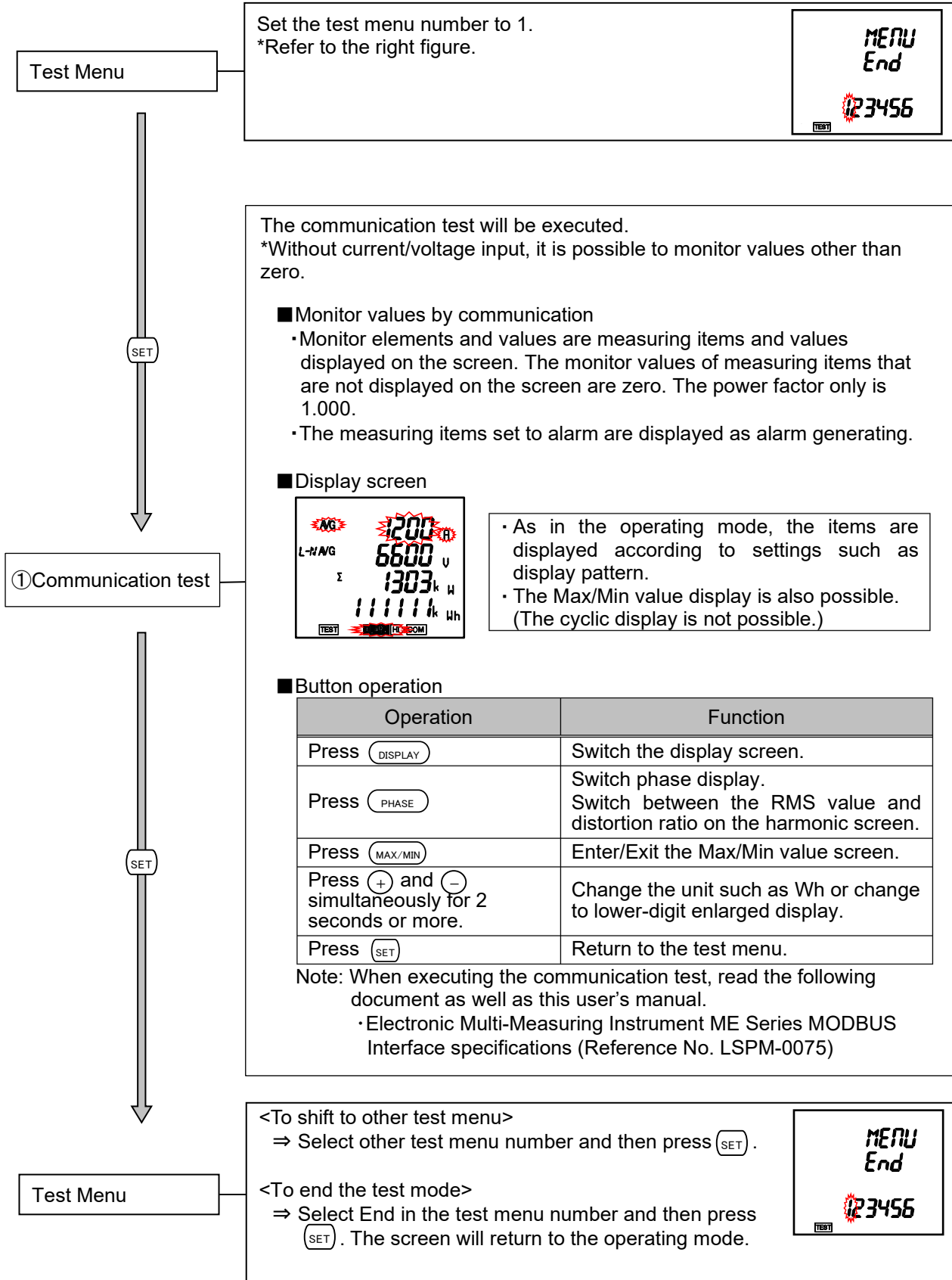

4. How to Use Test Mode

4.2. Test Menu 2 to 5: No Test Menu

This test menu is not displayed because there is no corresponding function in this model.

4.3. Test Menu 6: Functions for Determining Incorrect Wiring

In the test mode, the following operation is available.

Test Menu

Set the test menu number to 6.
*Refer to the right figure.

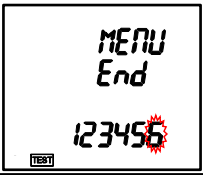

DISPLAY SET

When either a voltage input or a current input is incorrectly wired, this function automatically determines incorrect wiring and the incorrect part is displayed on the screen. After checking it, press (SET) to return to the test menu.

Example of correct wiring

The incorrect wiring part blinks.
*1
The correct one is ON.
The number of incorrect wiring pattern appears.
*For details on the pattern, refer to 4.3.1.

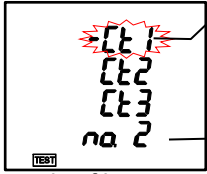
Example of incorrect wiring:
Reverse connection of 1 side CT



*1. For 1-phase 3-wire system, the PN terminal is displayed as 'P2' on the screen. Read as 'PN.'

① Pattern display of incorrect wiring

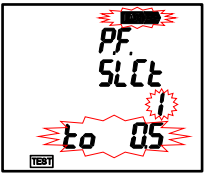
■ Select a power factor condition (For 3-phase 3-wire system)
For 3-phase 3-wire system, the following screen may be displayed to select a power factor condition depending on the incorrect wiring situation.
With (+) or (-), select the power factor condition and then press (SET).
When the settings are determined, the incorrect wiring part is displayed on the screen.



+



+

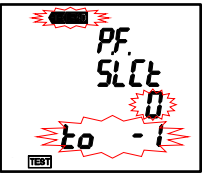

Power factor: LAG

Power factor: Around 1

Power factor: LEAD

Note: Select a power factor condition by referring to the following points:

- Power factor: LAG → Power factor is lagging for load of inductive machines. Assume 1 to lag 0.5.
- Power factor: Around 1 → Power factor is around 1 due to resistance load or power factor improvement. Assume lead 0.866 to lag 0.866.
- Power factor: LEAD → Power factor is leading for capacitor panel. Assume lead 0 to 1.

*If the Err display appears at the bottom line of the LCD, press (-) and then select the power factor condition again.

■ Check multiple alternatives (For 3-phase 3-wire/1-phase 3-wire/1-phase 2-wire system)
There may be multiple patterns of incorrect wiring depending on the incorrect wiring situation. For the above three systems, press (DISPLAY) to switch the screen and check the incorrect wiring patterns.

Display the first pattern in the three patterns

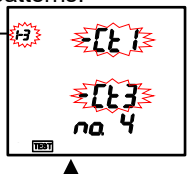

DISPLAY

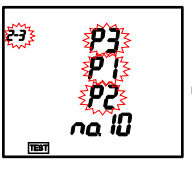

DISPLAY



DISPLAY

■ There are multiple incorrect wiring parts (For 3-phase 4-wire system)
For this phase wire system, multiple incorrect wiring parts of voltage or those of current are detected and displayed on each screen.



Example of voltage



Example of current

Continued to the next page.

4. How to Use Test Mode

4.3. Test Menu 6: Functions for Determining Incorrect Wiring

Continued from the previous page.

■ It is not possible to detect incorrect wiring

If the screen is displayed as the following, it is not possible to detect incorrect wiring.

Check measurement (voltage/current) input or press (+) to check (2)Support display for determining incorrect wiring.

Display	Description
01	This is low voltage. Apply about 70 percent or more of the direct voltage or secondary voltage setting.
02	This is low current. Apply about 5 percent or more of the rated current of the instrument.
03	This is in the unbalanced state. For 3-phase 3-wire system, it is not possible to detect incorrect wiring if there is a 10 percent or more difference between values in 1-phase and 3-phase of current.
04	There may be multiple incorrect wiring parts. Check (2)Support display for determining incorrect wiring.

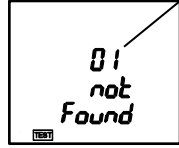

Phase angle, active power, voltage, and current will be displayed.

<For 3-phase 4-wire system>

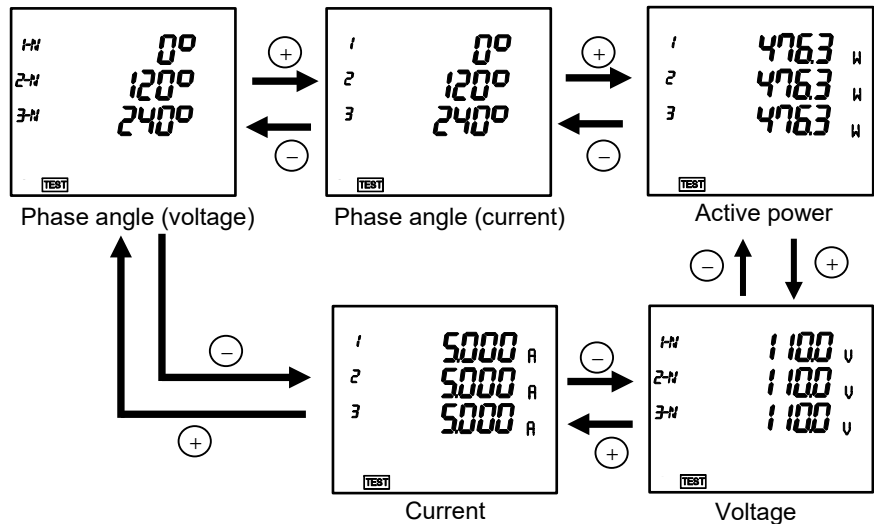

(2)Support display for determining incorrect wiring



<For 3-phase 3-wire system>

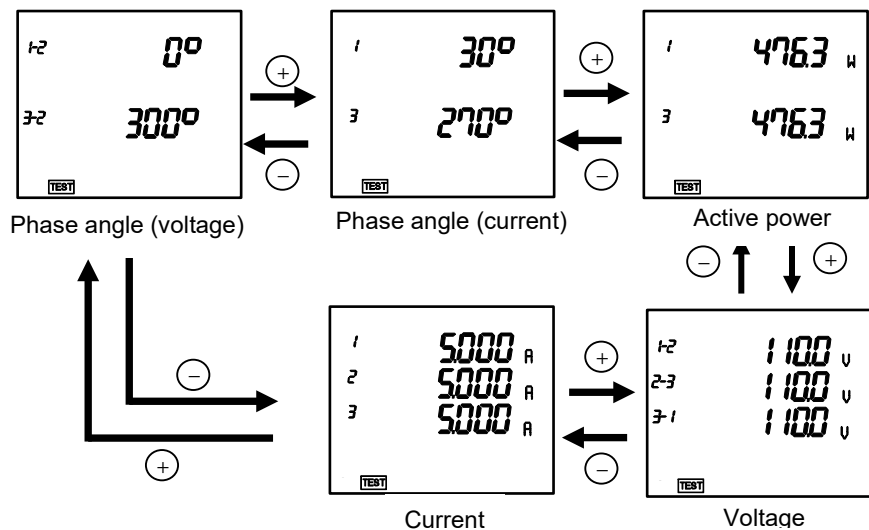

Continued to the next page.

4. How to Use Test Mode

4.3. Test Menu 6: Functions for Determining Incorrect Wiring

Continued from the previous page.

■ Phase angle

The phase angle is displayed clockwise based on V_{12} (0 degree).

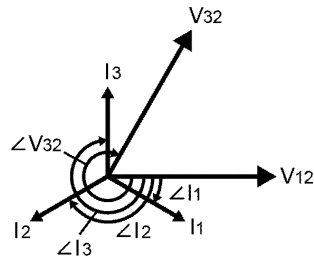

$\angle V_{32}$: Phase angle between V_{32} and V_{12}

$\angle I_1$: Phase angle between I_1 and V_{12}

$\angle I_3$: Phase angle between I_3 and V_{12}

Note: For 1-phase 3-wire, read each phase as follows.

$V_{12} \rightarrow V_{1N}$

$V_{32} \rightarrow V_{3N}$

$I_3 \rightarrow I_2$ or I_3

■ Display examples for incorrect wiring support function

For display examples of each incorrect wiring, refer to **9.2 A List of Examples for Incorrect Wiring Display**.

<To shift to other test menu>

⇒ Select other test menu number and then press **SET**.

Test Menu

<To end the test mode>

⇒ Select End in the test menu number and then press **SET**.

The screen will return to the operating mode.

4. How to Use Test Mode

4.3. Test Menu 6: Functions for Determining Incorrect Wiring

4.3.1. Incorrect Wiring Patterns Detected by ① Pattern display of incorrect wiring

This function is designed with the assumption that either a current input or a voltage input is incorrectly wired in positive phase sequence. It is not possible to determine all incorrect wiring. Dashed lines indicate incorrect wiring parts.

■ For 3-phase 4-wire system

No.	Wiring diagram	No.	Wiring diagram	No.	Wiring diagram	No.	Wiring diagram
1	Normal 	3	Reverse connection of 2 side CT 	8	Reverse connection of 1 side CT, 2 side CT, and 3 side CT 	13	Reverse connection between terminals P2 and P3
	Reversed phase sequence 1 *1 	4	Reverse connection of 3 side CT 	9	Switch between 1 side CT and 2 side CT 	14	Reverse connection between terminals P1 and P3
	Reversed phase sequence 2 *1 	5	Reverse connection of 1 side CT and 2 side CT 	10	Switch between 2 side CT and 3 side CT 	15	Reverse connection between terminals P1 and PN
	Reversed phase sequence 3 *1 	6	Reverse connection of 2 side CT and 3 side CT 	11	Switch between 1 side CT and 3 side CT 	16	Reverse connection between terminals P2 and PN
2	Reverse connection of 1 side CT 	7	Reverse connection of 1 side CT and 3 side CT 	12	Reverse connection between terminals P1 and P2 	17	Reverse connection between terminals P3 and PN

*1. Correct measurement is possible even in reversed phase sequence.

*2. For low voltage circuits, it is not necessary to ground the VT and CT secondary side circuits.

4. How to Use Test Mode

4.3. Test Menu 6: Functions for Determining Incorrect Wiring

4.3.1. Incorrect wiring patterns detected by ①Pattern display of incorrect wiring

■ For 3-phase 3-wire system

No.	Wiring diagram	No.	Wiring diagram	No.	Wiring diagram
1	<p>Normal</p>	6	<p>Reverse connection between terminals P1 and P2</p>	11	<p>Reverse connection of 1 side VT</p>
2	<p>Reverse connection of 1 side CT</p>	7	<p>Reverse connection between terminals P2 and P3</p>	12	<p>Reverse connection of 3 side VT</p>
3	<p>Reverse connection of 3 side CT</p>	8	<p>Reverse connection between terminals P1 and P3</p>	13	<p>Reverse connection of 1 side VT and 3 side VT</p>
4	<p>Reverse connection of 1 side and 3 side CT</p>	9	<p>P2, P3, and P1 terminals of VT are connected to P1, P2, and P3 terminals of the instrument in that order.</p>	14	<p>Reversed phase sequence *1</p>
5	<p>Switch between 1 side CT and 3 side CT</p>	10	<p>P3, P1, and P2 terminals of VT are connected to P1, P2, and P3 terminals of the instrument in that order</p>		

*1. Correct measurement is possible even in reversed phase sequence.

*2. For low voltage circuits, it is not necessary to ground the VT and CT secondary side circuits.

4. How to Use Test Mode

4.3. Test Menu 6: Functions for Determining Incorrect Wiring

4.3.1. Incorrect wiring patterns detected by ① Pattern display of incorrect wiring

■ For 1-phase 3-wire system *1

No.	Wiring diagram	No.	Wiring diagram	No.	Wiring diagram
1	<p>Normal</p>	5	<p>Switch between 1 side CT and 3 side CT</p>	8	<p>Reverse connection between terminals P1 and P3</p>
2	<p>Reverse connection of 1 side CT</p>	6	<p>Reverse connection between terminals P1 and PN</p>	9	<p>PN, P3, and P1 are connected to P1, PN, and P3 terminals of the instrument in that order.</p>
3	<p>Reverse connection of 3 side CT</p>	7	<p>Reverse connection between terminals PN and P3</p>	10	<p>P3, P1, and PN are connected to P1, PN, and P3 terminals of the instrument in that order.</p>
4	<p>Reverse connection of 1 side and 3 side CT</p>				

*1. On the screen, the PN terminal is displayed as 'P2'. Read as 'PN.'

■ For 1-phase 2-wire system

No.	Wiring diagram	No.	Wiring diagram
1	<p>Normal</p>	2	<p>Reverse connection of 1 side CT</p>

5. Operation

5.1. Basic Operation

The following charts illustrate how to use basic operation.

The display item and order vary depending on the phase wire system, display pattern, and additional screen.

For details on the display pattern, refer to **6.1 Display Pattern List**.

5.1.1. How to Switch the Measurement Screen

Press **DISPLAY** to switch the measurement screen.

In addition, by pressing **DISPLAY** and **+** or **-**, the measurement screen is switched in reverse.

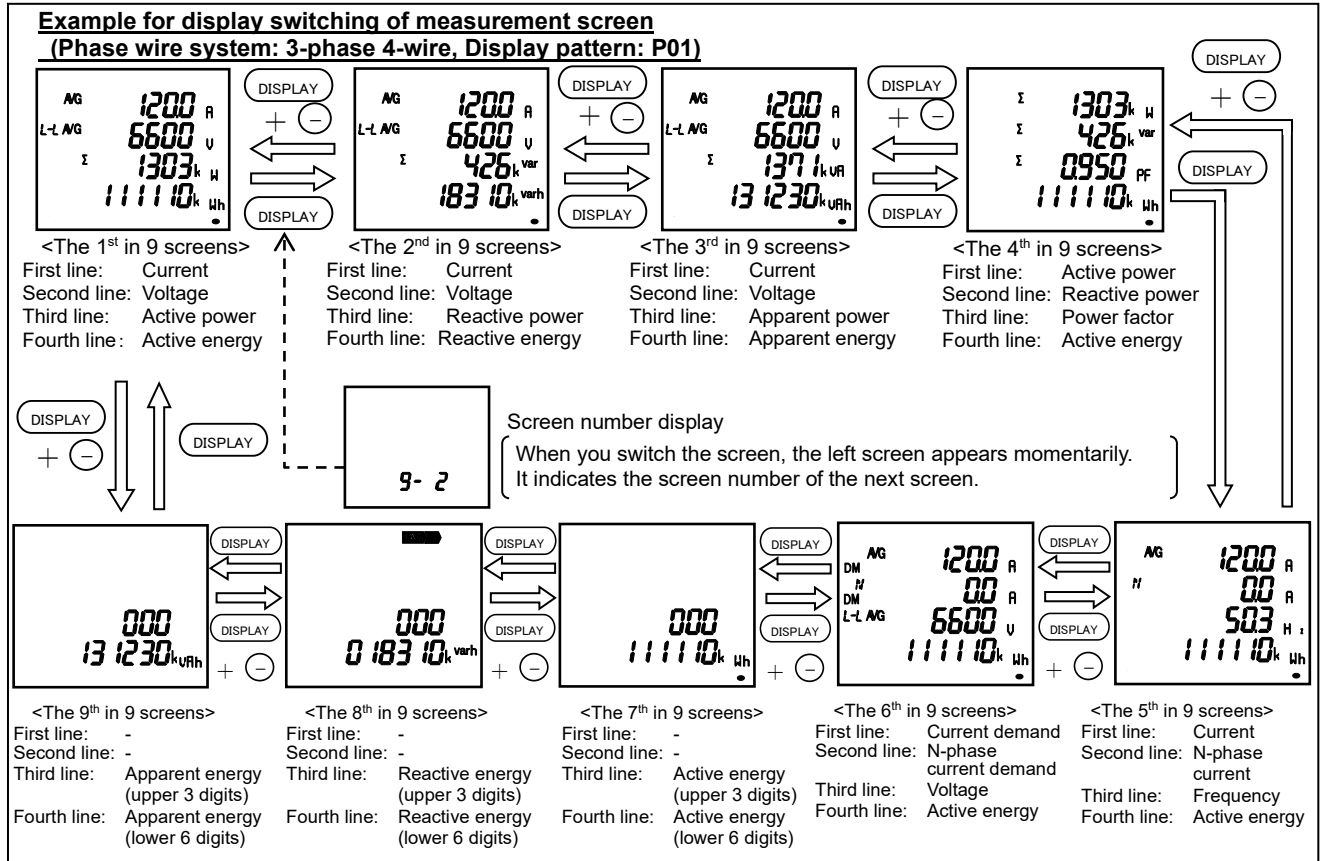

5.1.2. How to Switch Phase Display

The phase switching is not available in the following cases:

- Measuring element without phase (Frequency)
- Active power, reactive power, apparent power, and power factor for other than 3-phase 4-wire system
- 1-phase 2-wire system setting

Press **PHASE** to switch the phase of voltage/current.

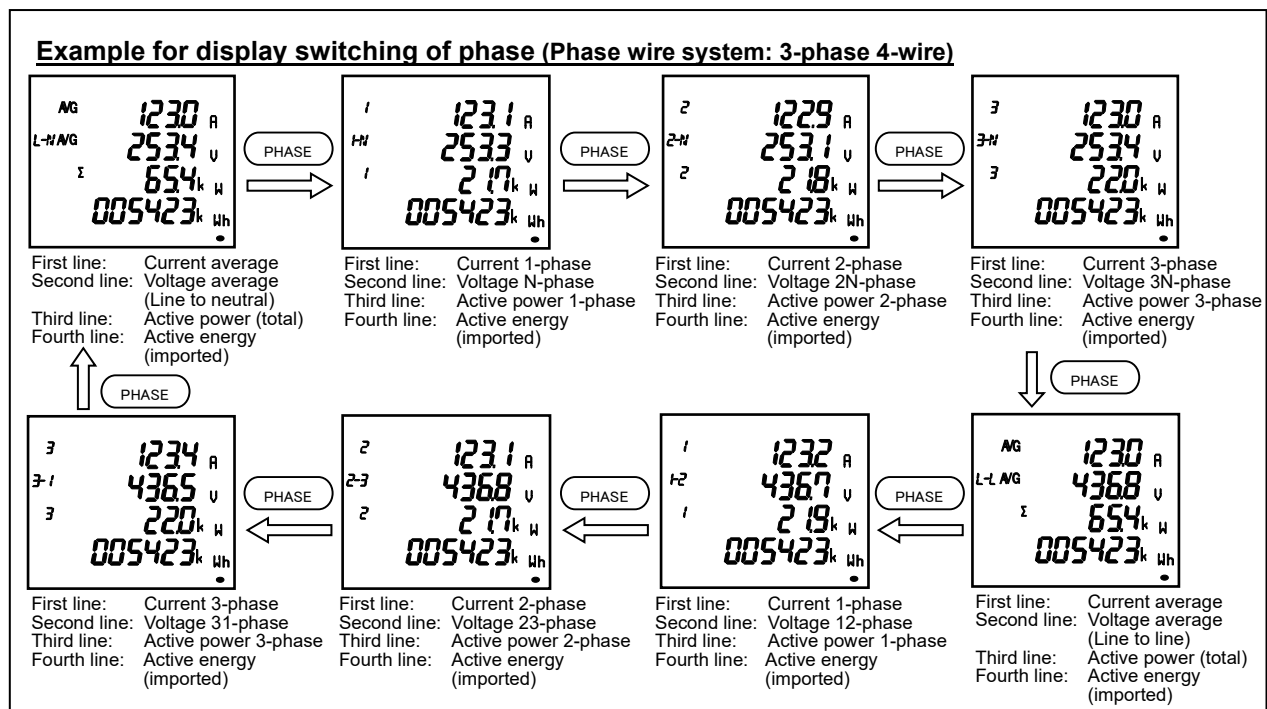

5. Operation

5.1. Basic Operation

5.1.3. How to Display in Cyclic Mode

In the cyclic mode, the measurement screen or phase display automatically switches every 5 seconds. When you press **DISPLAY** for 2 seconds, the screen enters the cyclic display mode of measurement screen. When you press **PHASE** for 2 seconds, the screen enters the cyclic display mode of phase. To end the cyclic mode, press any button other than **SET**.

Note 1: Before shift to the cyclic mode, the screen blinks 3 times.

Note 2: In the cyclic display mode of measurement screen, the screen number is not displayed at switching display.

Note 3: On the Max/Min value screen, the cyclic mode is available.

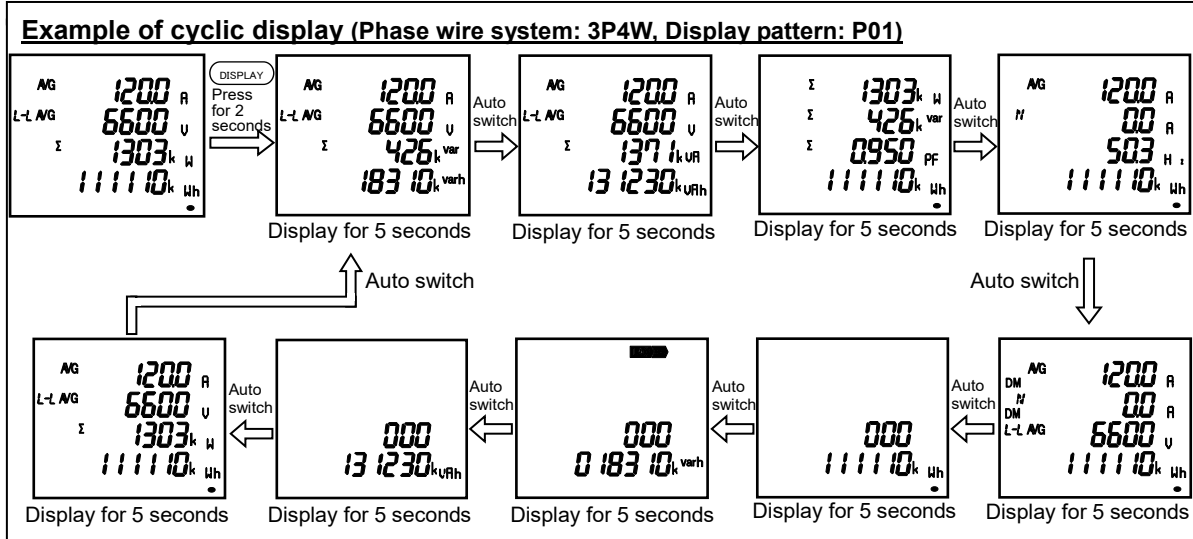

5.1.4. Harmonics Display

The harmonic RMS value and distortion ratio (content rate) can be displayed.

To display them, you must set the harmonics display. For details on the settings, refer to 3.4.

■ Measuring elements

Degree	Harmonic current		Harmonic current N-phase		Harmonic voltage	
	RMS value	Distortion Ratio (Content rate)	RMS value	Distortion Ratio (Content rate)	RMS value	Distortion Ratio (Content rate)
Harmonic total	○	○	○	—	○	○

■ Display example

<Harmonic current total>

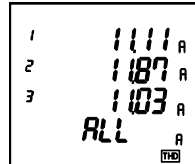

First line: 1-phase RMS value
Second line: 2-phase RMS value
Third line: 3-phase RMS value
Fourth line: Degree

Note: Degree total is displayed as "ALL."

■ How to switch the phase (Phase wire system: 3-phase 4-wire)

By pressing **PHASE**, the RMS value and distortion ratio (content rate) are switched.

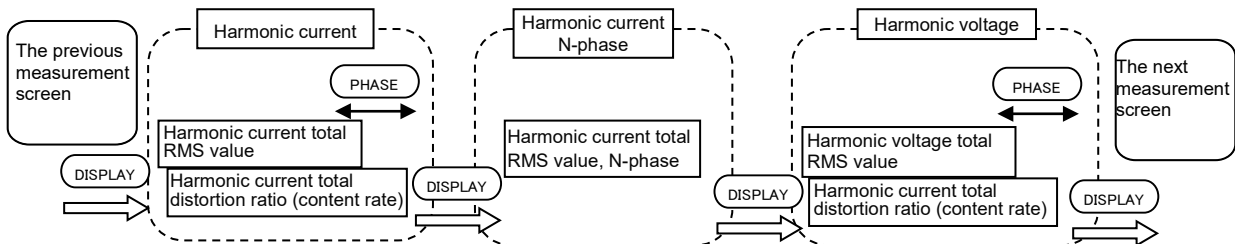

Note: For harmonics measurement, the following phases are not measured to display.

Phase wire system		Harmonic current	Harmonic voltage
3-phase 3-wire	3CT	—	31-phase
	2CT	2-phase	31-phase
1-phase 3-wire	1N2 display	N-phase	12-phase
	1N3 display	N-phase	13-phase

5. Operation

5.1. Basic Operation

5.1.5. Maximum/Minimum Value Display

On the Max/Min value screen, a maximum value, present value, and minimum value are displayed in one screen by measuring item.

- However, for harmonics, the following maximum value only is displayed.
- Harmonic current: The total RMS value of the phase where a value was the largest in every phase.
 - Harmonic voltage: The total distortion ratio of the phase where a value was the largest in every phase.

■ Display examples

<Example of Current>

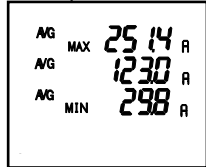

First line: Maximum value
Second line: Present value
Third line: Minimum value
Fourth line: -

<Example of Harmonic current>

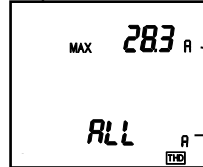

Maximum value
Harmonic degree

5.1.6. How to Display Maximum/Minimum values

When you press **(MAX/MIN)**, the screen switches to the Max/Min value display.

By pressing **(MAX/MIN)** again, the screen returns to the present value display.

Example for display switching between the present value and Max/Min value

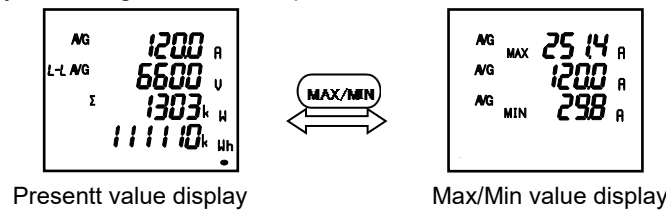

On the Max/Min value screen, the following display switching is available as the present value screen.

Button operation	Function
Press (DISPLAY)	Measuring items are switched in the following order. However, measuring items that are not included in the phase wire system, display pattern, and additional screen are not displayed. <pre> A → AN → DA → DAN → V → W → var HV ← HIN ← HI ← HZ ← PF ← VA </pre>
Press (PHASE)	For 3-phase 4-wire system, phases are switched in the following order: <ul style="list-style-type: none"> • A, DA: Average → 1 Phase → 2 Phase → 3 Phase • V: $V_{AVG(L-N)} \rightarrow V_{1N} \rightarrow V_{2N} \rightarrow V_{3N} \rightarrow V_{AVG(L-L)} \rightarrow V_{12} \rightarrow V_{23} \rightarrow V_{31}$ • W, var, VA, PF: Total → 1 Phase → 2 Phase → 3 Phase <ul style="list-style-type: none"> • AN, DAN, and Hz do not have phase switching. For 3-phase 3-wire/1-phase 3-wire system, the phases of A, DA and V are switched. For 1-phase 2-wire system, no phase is switched.
Press (DISPLAY) for 2 seconds	Enter the cyclic display mode of measurement screen.
Press (PHASE) for 2 seconds	Enter the cyclic display mode of phase.

5.1.7. How to Clear the Maximum/Minimum Values

On the Max/Min value screen, pressing **(RESET)** for 2 seconds clears the maximum and minimum values of the displayed measuring item and turns to the present values.

In addition, pressing **(RESET)** and **(+)** simultaneously for 2 seconds on the screen clears all maximum and minimum values and turns to the present values.

When password protection is enabled, the maximum and minimum values are cleared after you enter the password.

Communication function also enables to clear all maximum and minimum values. In this case, password input is not necessary.

5. Operation

5.1. Basic Operation

5.1.8. Active Energy/Reactive Energy/Apparent Energy Display

■ Display type

The following table shows the display type of active/reactive/apparent energy based on full-load power.

$$\text{Full-load power [kW]} = \frac{\alpha \times (\text{VT primary voltage}) \times (\text{CT primary current})}{1000}$$

}	α: 1	1-phase 2-wire
	2	1-phase 3-wire
	√3	3-phase 3-wire
	3	3-phase 4-wire

- *1. For 3-phase 4-wire system, VT primary voltage and direct voltage are calculated using phase voltage.
- *2. For 1-phase 3-wire system, VT primary voltage is calculated using phase voltage.
- *3. For the direct voltage setting, direct voltage is used for calculation instead of VT primary voltage.
- *4. For reactive energy and apparent energy, 'kW' in the above equation is read as 'kvar' and 'kVA' respectively.

Full-load power [kW]	Display type	
	Digital Display	Unit
Below 10	888888	kWh, kvarh, kVAh *The unit can be changed to 'M or none.'
10 or more and below 100		
100 or more and below 1000		
1000 or more and below 10000		
10000 or more and below 100000		
100000 or more	MWh, kvarh, kVAh *The unit can be changed to 'k or none.'	

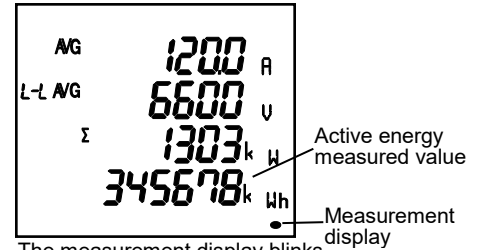

The measurement display blinks at measuring active energy (imported). It becomes OFF or ON at no measuring point.

■ Display examples

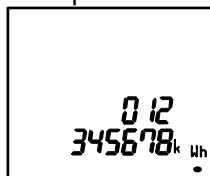

Active energy (imported)

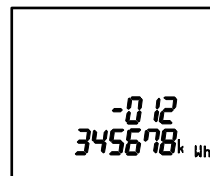

Active energy (exported)*1

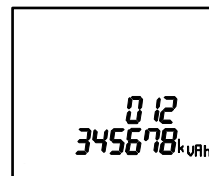

Apparent energy

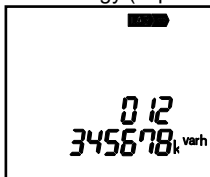

Reactive energy (imported lag)

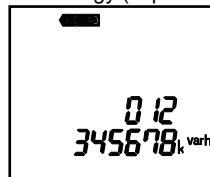

Reactive energy (imported lead)*1

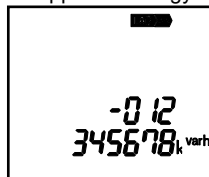

Reactive energy (exported lag)*1

To display the screen of *1, you must change the settings for active/reactive energy measurement in 3.4.

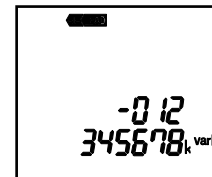

Reactive energy (exported lead)*1

5.1.9. How to Change the Display Digit of Active/Reactive/Apparent Energy

By changing the unit (M, k, or none) of active/reactive/apparent energy or by displaying the lower enlarged view, you can check the upper or lower digit of a measured value.

Press (+) and (-) simultaneously for 2 seconds to switch.

Example of switching active energy (imported): 012,345,678,901,234.567Wh

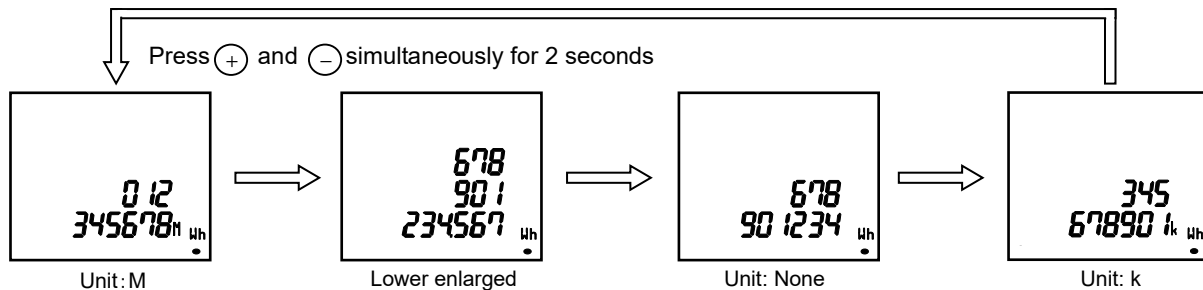

Note1: Active, reactive, and apparent energy that are not displayed on the screen will be also all changed to the same unit.

Note2: If the set value of VT primary voltage or that of CT primary current is large, the lower digit less than the measurement range will indicate '0.'

5. Operation

5.1. Basic Operation

5.1.10. How to Reset Active/Reactive/Apparent Energy to Zero

Pressing **SET**, **RESET**, and **PHASE** simultaneously for 2 seconds resets active, reactive, and apparent energy values to zero.

When password protection is enabled, the values are reset after you enter the password.

In addition, communication function enables to reset all active, reactive, and apparent energy values to zero.

In this case, password input is not necessary.

- (Note1: This function is available on the present value screen only.
 Note2: The values that are not displayed on the screen will be also all reset to zero.)

5.1.11. How to Measure Reactive Energy (2 quadrant/4 quadrant measurement)

For measurement of reactive energy, there are two types on how to take a quadrant as follows.

The measurement method of reactive energy can be switched at the active/reactive energy measurement setting in the setting menu 3.

In addition, when you set to IEC mode in the setting menu 8, 2 quadrant measurement is executed even if you set to 'Combination III' or 'Combination IV', which executes 4 quadrant measurement, at the active/reactive energy measurement setting.

When you select 4 quadrant measurement and IEC mode at each setting, 'Imported lag' and 'Exported lead' of reactive energy are displayed on the additional screen. However, they are not integrated.

For details on how to switch 2 quadrant/4 quadrant measurement, refer to **3.4**.

For details on how to switch the IEC mode setting, refer to **3.9**.

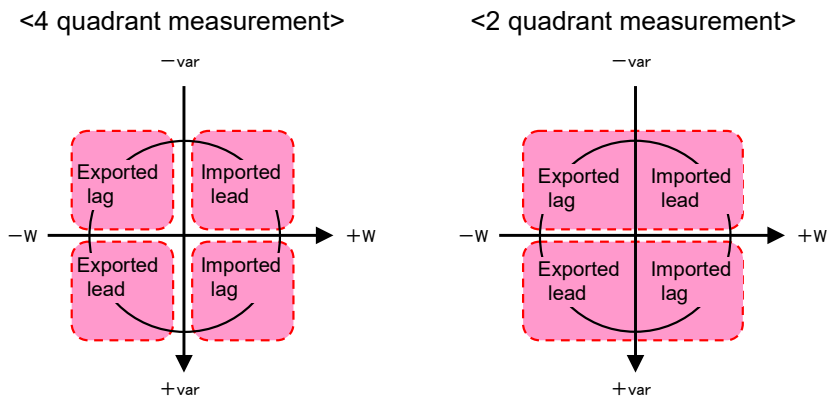

Measurement method	Description
4 quadrant measurement	Each of four quadrants (Imported lag, Imported lead, Exported lag, and Exported lead) is measured as one division. It is suitable to measure systems with a private power generator. However, a dead region occurs at the boundary of each division. Accordingly, reactive energy cannot be measured at where power factor is near 1 or zero.
2 quadrant measurement	'Imported lag' and 'Exported lead' are measured as one division, and in the same way, 'Imported lead' and 'Exported lag' are measured as one division. Therefore, a dead region does not occur at where power factor is near zero, and reactive energy can be measured even there. It is suitable to measure systems without a private power generator and reactive energy of capacitor load where power factor is zero generally.

5. Operation

5.1. Basic Operation

5.1.12. Each Measuring Item Display during Power Transmission

The following table shows symbol display (\pm) for each measured value according to the power transmission state.

For details on how to switch 2 quadrant/4 quadrant measurement, refer to 3.4.

For details on how to switch the IEC mode setting, refer to 3.9.

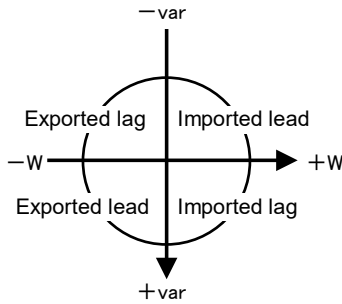

Power transmission state		Imported lag	Imported lead	Exported lag	Exported lead
		Measuring item			
A, DA, AN, DAN, V, Hz, VA, HI, HV, HIN		Unsigned			
W		Unsigned		'-' sign	
var	Normal mode (2 quadrant measurement)	Unsigned	'-' sign	'-' sign	Unsigned
	Normal mode (4 quadrant measurement)	Unsigned	'-' sign	Unsigned	'-' sign
	IEC mode (2 quadrant measurement)	Unsigned	'-' sign	'-' sign	Unsigned
PF	Normal mode (2 quadrant measurement)	Unsigned	'-' sign	'-' sign	Unsigned
	Normal mode (4 quadrant measurement)	Unsigned	'-' sign	Unsigned	'-' sign
	IEC mode (2 quadrant measurement)	Unsigned	'-' sign	Unsigned	'-' sign

5.1.13. Demand Time Period and Demand Value of Current demand

The demand time period (t_0) represents a time period until a measured value (I_0) displays 95% of the input (I) when continuously energized by constant input (I). To display 100% of the input (I), approximately three times the time period (t_0) is required.

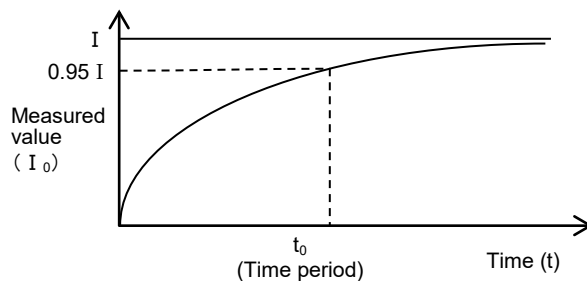

The demand value represents a measured display value with the above feature on time period and it indicates the overall average value within the demand time period.

The demand value changes over a relatively long time period. Therefore, it is not affected by input change for a short time. Accordingly, it is suitable to monitor overload of transformer.

5. Operation

5.2. Usage Depending on the Application (Alarm, Operating Time, Password, etc.)

The following shows how to use the instrument depending on the application.

5.2.1. Upper/Lower Limit Alarm Display and Action

When the set upper/lower limit alarm value is exceeded, the display starts to blink.

*For details on how to set the upper/lower limit alarm, refer to 3.6.

■ Action in case of alarm

Alarm generating: When the set alarm value is exceeded, the display blinks. *Note

Alarm cancellation: When an alarm is cancelled, the display turns to the normal mode.

Note: When you set the alarm delay time, an alarm will generate if the set upper/lower limit alarm value is exceeded and this situation continues for the alarm delay time.

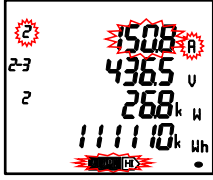
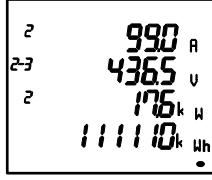
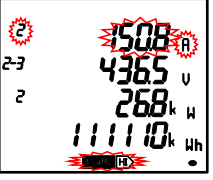
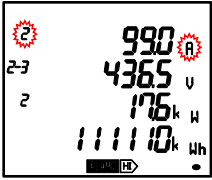
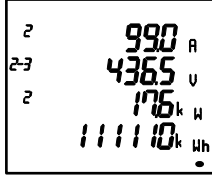
Alarm reset method		Measured value > Upper limit alarm value Measured value < Lower limit alarm value	Measured value < Upper limit alarm value Measured value > Lower limit alarm value
Automatic (Auto)	Screen	<p>ALARM and [HI] or [LO] blink</p> 	<p>Normal display</p> 
		<p>ALARM and [HI] or [LO] blink</p>  <p>(Alarm generating)</p>	<p>ALARM and [HI] or [LO] light up</p>  <p>(Alarm retention)</p> <p>RESET →</p> <p>Normal display</p>  <p>(Alarm cancellation)</p>

Note1: If measuring elements of alarm generating are displayed on the screen, the digital value, unit (A, V, W, PF, Hz, %, DM, and THD), and phase (1, 2, 3, and N) will be displayed according to the alarm status as the following table.

Alarm status	Digital value	Unit	Phase
Alarm generating	Blink*	Blink	Blink*
Alarm retention	Light up	Blink	Blink*
Alarm cancellation	Light up	Light up	Light up

*When the phase of no alarm is displayed on the screen, it does not blink.

Note2: When the backlight blinking is set to 'on' in case of alarm, the backlight blinks at generating alarm.

Note3: On the Max/Min value screen, the present value, which is displayed at the middle line of digital display,

ALARM and **[HI]** or **[LO]** blink.

■ Monitored phase of upper/lower limit alarm item

The phase for monitoring the upper/lower limit alarm varies depending on the measuring item.

For details, refer to the following table.

Upper/Lower limit alarm item	Monitored phase			
	3-phase 4-wire	3-phase 3-wire (3CT, 2CT)	1-phase 3-wire (1N2)	1-phase 3-wire (1N3)
A upper limit, DA upper limit	1, 2, 3	1, 2, 3	1, N, 2	1, N, 3
A lower limit, DA lower limit	1, 2, 3	1, 2, 3	1, 2	1, 3
A _N upper limit, DA _N upper limit	N	—	—	—
A _N lower limit, DA _N lower limit	N	—	—	—
V (L-L) upper limit Note1	12, 23, 31	12, 23, 31	1N, 2N, 12	1N, 3N, 31
V (L-L) lower limit Note1	12, 23, 31	12, 23, 31	1N, 2N, 12	1N, 3N, 31
V (L-N) upper limit	1N, 2N, 3N	—	—	—
V (L-N) lower limit	1N, 2N, 3N	—	—	—
W upper limit, var upper limit, PF upper limit	Total	Total	Total	Total
W lower limit, var lower limit, PF lower limit	Total	Total	Total	Total
Hz upper limit	1N	12	1N	1N
Hz lower limit	1N	12	1N	1N
HI total upper limit	1, 2, 3	1, 2, 3 *Note2	1, 2	1, 3
HI _N total upper limit	N	—	—	—
THD _V upper limit	1N, 2N, 3N	12, 23	1N, 2N	1N, 3N

Note1: For 12-phase or 31-phase of 1-phase 3-wire system, alarm monitoring is executed based on twice the set upper/lower limit alarm value.

Note2: Harmonic current 2-phase is measured for 3-phase 3-wire system (3CT) only.

5. Operation

5.2. Usage Depending on the Application (Alarm, Operating Time, Password, etc.)

5.2.2. How to Cancel the Upper/Lower Limit Alarm

The alarm cancellation method differs depending on the alarm reset setting. In addition to the following methods, communication function is available to cancel the upper and lower limit alarm.

Alarm reset method	How to cancel
Automatic (Auto)	When a measured value is below the set upper/lower limit alarm value, the alarm is automatically reset.
Manual (HoLd)	<p>Even after a measured value is below the set upper/lower limit alarm value, the alarm is retained. After the measured value is below the alarm value, operate the following alarm reset.</p> <p>*Note: On the Max/Min value screen, it is not possible to operate the alarm reset.</p> <p><To cancel the alarm of a selected item> Display the item of alarm generating and then press RESET to cancel the alarm. (For the item that has phases such as current or voltage, you must press RESET on each phase to cancel the alarm.)</p> <p><To cancel alarms of all items> In the operating mode, press RESET for 2 seconds to cancel all alarms at once.</p>

Note: To prevent chattering, the determination whether a measured value is below the upper/lower limit alarm value is conducted out of dead region below the setting step of the alarm value.

5.2.3. How to Stop Backlight Blinking Caused by the Upper/Lower Limit Alarm

Press **RESET** to stop the backlight blinking.

5.2.4. Operating Time Display

According to the value set to the operating time count target (AUX, A, and V), measuring time is counted and displayed as operating time of load. To display it, you must set the operating time display.

Even when the operating time display is set to 'oFF (Not display)', operating time is counted.

*For details on the settings, refer to 3.9.

When the threshold of the following items you set for operating time count target is exceeded, operating time 1 and 2 are counted.

Item	3-phase 4-wire	1-phase 2-wire	Others
AUX (Auxiliary power)	AUX	AUX	AUX
A (Current)	AAVG	A	AAVG
V (Voltage)	V _{AVG} (L-N)	V	V _{AVG} (L-L)

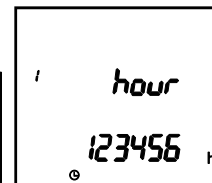

Operating time 1

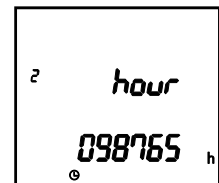

Operating time 2

In the operating mode, when you are switching the measurement screen with **DISPLAY**, operating time is displayed.

5.2.5. How to Reset Operating Time to Zero

When operating time 1 or operating time 2 is displayed on the screen, pressing **RESET** for 2 seconds resets the operating time to zero.

*The operating time displayed on the screen only is reset to zero.

When password protection is enabled, it is reset to zero after you enter the password.

In addition, communication function enables to reset all operating time to zero. In this case, password input is not necessary.

5. Operation

5.2. Usage Depending on the Application (Alarm, Operating Time, Password, etc.)

5.2.6. How to Prevent the Maximum Value Update by Motor Starting Current

For motor current monitoring, the use of motor starting current delay function prevents the maximum value update of current, active power, reactive power, apparent power, and power factor and alarm generating that are caused by motor starting current. To use the motor starting current delay function, you must set it. For details on the settings, refer to 3.6.

■ The action with motor starting current delay function

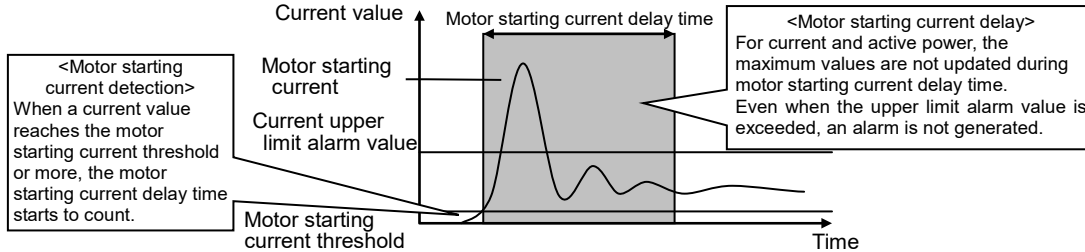

Note1: For motor starting current threshold, set a value lower than the lower limit value, considering a change in load current during operation.

Note2: When an input current value is below the motor starting current threshold, the minimum value update stops.

5.2.7. Password Protection Setting

In the operating mode, when you press **RESET** and **PHASE** simultaneously for 2 seconds or more and then enter the password, the password protection can be set.

The password of the factory default is '0000.' If you enter the wrong password, the screen will return to the password input display, where the highest digit blinks.

To switch from the password input screen to the operating mode, press **DISPLAY** at the highest digit in password input.

When the password protection is enabled, you must input the password when executing the following item such as setting mode switching or Max/Min value reset.

■ Password input

Password input screen

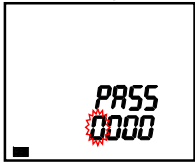

- Set the number for the blinking digit from the highest digit by pressing **+** or **-**.
- Press **SET** to move the setting digit, blinking one, to a lower digit.
- Press **DISPLAY** to move the setting digit, blinking one, to an upper digit.
- Press **SET** at the lowest digit to enable the items in the right table.
- If you enter the wrong password, the screen will return to the display where the highest digit is blinking.

■ Password protected item

No.	Item
1	Enter the setting mode
2	Clear Max/Min values
3	Reset Wh, var, etc. to zero
4	Reset operating time to zero

■ Password protection settings

(1) Set the password protection.

oFF ← → on

(Disable protection) (Enable protection)

(2) Change the password.

no ← → yES
(Not change) (Change)

Note1: When you select "no", the screen returns to the operating mode.

Note2: When you select "yES", the setup password appears.

(3) Input a new password.

- Set the number for the blinking digit from the highest digit by pressing **+** or **-**.
- Press **SET** to move the setting digit, blinking one, to a lower digit.
- Press **DISPLAY** to move the setting digit, blinking one, to a higher digit.
- Press **SET** to determine the password change.
- The setting range is 0000 to 9999.

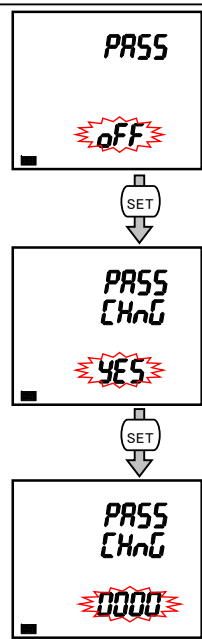

Important

If you forgot your password, you could not unlock the password by yourself in the field. Please contact your supplier.

6. Others

6.1. Display Pattern List

When you set the display pattern in the setting menu 1 and the additional screens in the setting menu 3 and 8, the screen is switched from No.1 in the following table in ascending order by pressing .

[When set to 3-phase 4-wire system]

Display pattern		Screen set by display pattern									
		No.1	No.2	No.3	No.4	No.5	No.6	No.7	No.8	No.9	No.10
P01	First	A	A	A	W	A	DA				
	Second	V	V	V	var	AN	DAN				
	Third	W	var	VA	PF	Hz	V				
	Fourth	Wh	varh	VAh	Wh	Wh	Wh				
P02	First	A1	DA1	V1N	W1	var1	VA1	PF1	A	A	DA
	Second	A2	DA2	V2N	W2	var2	VA2	PF2	Hz	AN	DAN
	Third	A3	DA3	V3N	W3	var3	VA3	PF3	W	var	VA
	Fourth	Aavg	DAavg	VLN avg	WΣ	varΣ	VAΣ	PFΣ	Wh	varh	VAh
P00	First	Arbitrary 1	Arbitrary 1	Arbitrary 1	Arbitrary 1						
	Second	Arbitrary 1	Arbitrary 1	Arbitrary 1	Arbitrary 1						
	Third	Arbitrary 1	Arbitrary 1	Arbitrary 1	Arbitrary 1						
	Fourth	Arbitrary 2	Arbitrary 2	Arbitrary 2	Arbitrary 2						

Note1: For arbitrary 1, selectable items are A, AN, DA, DAN, V, W, var, VA, PF, and Hz.
For arbitrary 2, Wh, -Wh, varh, and VAh are selectable.

Display pattern		Additional screen (Set in the setting menu 3 and 8)											
		No.11	No.12	No.13	No.14	No.15	No.16	No.17	No.18	No.19	No.20	No.21	No.22
		Wh	Wh (exported)	varh	varh imported (lead)	varh exported (lag)	varh exported (lead)	VAh	Harmonic current	Harmonic current N-phase	Harmonic voltage	Operating time 1	Operating time 2
Common to display patterns from P00 to P02	First	-	-	-	-	-	-	-	1-phase value	N-phase value	1-phase value	-	-
	Second								2-phase value	-	2-phase value	hour 1	hour 2
	Third	Wh	Wh exported	varh	varh imported (lead)	varh exported (lag)	varh exported (lead)	VAh	3-phase value	-	3-phase value	-	-
	Fourth								Degree	Degree	Degree	Operating time	Operating time

Note 2: When you add an additional screen, the screen number is added.

Note 3: In the table, 'Wh' and 'varh' indicate active energy (imported) and reactive energy (imported lag) respectively.

Note 4: The additional screens of Wh, varh, and VAh of P00 are displayed by setting each item as display element.

6. Others

6.1. Display Pattern List

[When set to other than 3-phase 4-wire system]

Display pattern		Screen set by display pattern					
		No.1	No.2	No.3	No.4	No.5	No.6
P01	First	A	A	A	W	A	
	Second	V	V	V	var	DA	
	Third	W	var	VA	PF	Hz	
	Fourth	Wh	varh	VAh	Wh	Wh	
P02	First	A1	DA1	V12	W	A	A
	Second	A2	DA2	V23	var	Hz	V
	Third	A3	DA3	V31	PF	var	VA
	Fourth	Aavg	DAavg	Vavg	Wh	varh	VAh
P00	First	Arbitrary 1	Arbitrary 1	Arbitrary 1	Arbitrary 1		
	Second	Arbitrary 1	Arbitrary 1	Arbitrary 1	Arbitrary 1		
	Third	Arbitrary 1	Arbitrary 1	Arbitrary 1	Arbitrary 1		
	Fourth	Arbitrary 2	Arbitrary 2	Arbitrary 2	Arbitrary 2		

Note1: For 1-phase 2-wire system, it is not possible to set the display pattern of P02.

Note2: For arbitrary 1, selectable items are A, DA, V, W, var, VA, PF, and Hz.

For arbitrary 2, Wh, -Wh, varh, and VAh are selectable.

Note3: The phase shown in the display pattern of P02 is displayed on the screen according to the phase wire system as the following table.

Phase wire system Phase display		1-phase 3-wire (1N2)	1-phase 3-wire (1N3)	3-phase 3-wire
		Current	1	1
	2	N	N	2
	3	2	3	3
Voltage	12	1N	1N	12
	23	2N	3N	23
	31	12	13	31

Display pattern		Additional screen (Set in the setting menu 3 and 8)										
		No.7	No.8	No.9	No.10	No.11	No.12	No.13	No.14	No.15	No.16	No.17
		Wh	Wh (exported)	varh	varh imported (lead)	varh exported (lag)	varh exported (lead)	VAh	Harmonic current	Harmonic voltage	Operating time 1	Operating time 2
Common to display patterns from P00 to P02	First	-	-	-	-	-	-	-	1-phase value	1-phase value	-	-
	Second	Wh	Wh exported	varh	varh imported (lead)	varh exported (lag)	varh exported (lead)	VAh	2-phase value	3-phase value	hour 1	hour 2
	Third								3-phase value	-	-	-
	Fourth								Degree	Degree	Operating time	Operating time

Note4: When you add an additional screen, the screen number is added.

Note5: In the table, 'Wh' and 'varh' indicate active energy (imported) and reactive energy (imported lag) respectively.

Note6: The additional screens of Wh, varh, and VAh of P00 are displayed by setting each item as display element.

Note7: The display of additional screens of No.14 and 15 in the above table varies depending on the setting of the phase wire system as the following table.

Phase display		Phase wire system			
		1-phase 2-wire	1-phase 3-wire	3-phase 3-wire (2CT)	3-phase 3-wire (3CT)
Harmonic current	1-phase value	○	○	○	○
	2-phase value	—	—	—	○
	3-phase value	—	○	○	○
Harmonic voltage	1-phase value	○	○	○	○
	3-phase value	—	○	○	○

Others

6.2. Standard Value

When you set active power and reactive power as alarm element, the setting range is determined by the standard value calculated using the following calculation formula.

■ The standard value of active power/reactive power

Measuring element	Calculation method for standard value
Active power	VT ratio × CT ratio × Intrinsic power (100%) kW
Reactive power	

Note1: When you set to 'Without VT (Voltage direct input)', the VT ratio is 1. For intrinsic power, refer to the following table.

Note2: The calculated value is round to the nearest number as the table in the next page.

■ Intrinsic power

Phase wire system	CT secondary current	Rated voltage	Intrinsic power value (100%)	
1-phase 2-wire	5 A	Direct input (Line voltage)	110 V	0.5 kW
			220 V	1.0 kW
			440 V	2.0 kW
		With VT (Line voltage)	100 V, 110 V	0.5 kW
	220 V		1.0 kW	
	1 A	Direct input (Line voltage)	110 V	0.1 kW
			220 V	0.2 kW
			440 V	0.4 kW
With VT (Line voltage)		100 V, 110 V	0.1 kW	
	220 V	0.2 kW		
1-phase 3-wire	5 A	Without VT (Line voltage)	220 V	1.0 kW
			440 V	2.0 kW
	1 A		220 V	0.2 kW
			440 V	0.4 kW
3-phase 3-wire	5 A	Direct input (Line voltage)	110 V	1.0 kW
			220 V	2.0 kW
			440 V	4.0 kW
		With VT (Line voltage)	100 V, 110 V	1.0 kW
	220 V		2.0 kW	
	1 A	Direct input (Line voltage)	110 V	0.2 kW
			220 V	0.4 kW
			440 V	0.8 kW
With VT (Line voltage)		100 V, 110 V	0.2 kW	
	220 V	0.4 kW		
3-phase 4-wire	5 A	Direct input	63.5/110 V	1.0 kW
			100/173 V	2.0 kW
			110/190 V	
			220/380 V	4.0 kW
			230/400 V	
			240/415 V	
	With VT (Phase voltage)	254/440 V	5.0 kW	
		277/480 V		
	1 A	With VT (Phase voltage)	63.5 V	1.0 kW
			100 V, 110 V, 115 V, 120 V	2.0 kW
		Direct input	63.5/110 V	0.2 kW
			100/173 V	0.4 kW
110/190 V				
220/380 V			0.8 kW	
240/415 V				
254/440 V				
With VT (Phase voltage)	277/480 V	1.0 kW		
	63.5 V	0.2 kW		
100 V, 110 V, 115 V, 120 V		0.4 kW		

Note: For reactive power and apparent power, read 'kW' in the above table as 'kvar' and 'kVA' respectively.

6. Others

6.2. Standard Value

The calculated value in the previous page is rounded to the nearest number as the following table.

Unit: W	Unit: W	Unit: kW	Unit: kW	Unit: MW	Unit: MW
8 W	300 W	9 kW	320 kW	9 MW	320 MW
9 W	320 W	9.6 kW	360 kW	9.6 MW	360 MW
9.6 W	360 W	10 kW	400 kW	10 MW	400 MW
10 W	400 W	12 kW	450 kW	12 MW	450 MW
12 W	450 W	15 kW	480 kW	15 MW	480 MW
15 W	480 W	16 kW	500 kW	16 MW	500 MW
16 W	500 W	18 kW	600 kW	18 MW	600 MW
18 W	600 W	20 kW	640 kW	20 MW	640 MW
20 W	640 W	22 kW	720 kW	22 MW	720 MW
22 W	720 W	24 kW	750 kW	24 MW	750 MW
24 W	750 W	25 kW	800 kW	25 MW	800 MW
25 W	800 W	30 kW	900 kW	30 MW	900 MW
30 W	900 W	32 kW	960 kW	32 MW	960 MW
32 W	960 W	36 kW	1000 kW	36 MW	1000 MW
36 W	1000 W	40 kW	1200 kW	40 MW	1200 MW
40 W	1200 W	45 kW	1500 kW	45 MW	1500 MW
45 W	1500 W	48 kW	1600 kW	48 MW	1600 MW
48 W	1600 W	50 kW	1800 kW	50 MW	1800 MW
50 W	1800 W	60 kW	2000 kW	60 MW	2000 MW
60 W	2000 W	64 kW	2200 kW	64 MW	2200 MW
64 W	2200 W	72 kW	2400 kW	72 MW	2400 MW
72 W	2400 W	75 kW	2500 kW	75 MW	2500 MW
75 W	2500 W	80 kW	3000 kW	80 MW	3000 MW
80 W	3000 W	90 kW	3200 kW	90 MW	3200 MW
90 W	3200 W	96 kW	3600 kW	96 MW	3600 MW
96 W	3600 W	100 kW	4000 kW	100 MW	4000 MW
100 W	4000 W	120 kW	4500 kW	120 MW	4500 MW
120 W	4500 W	150 kW	4800 kW	150 MW	4800 MW
150 W	4800 W	160 kW	5000 kW	160 MW	5000 MW
160 W	5000 W	180 kW	6000 kW	180 MW	6000 MW
180 W	6000 W	200 kW	6400 kW	200 MW	6400 MW
200 W	6400 W	220 kW	7200 kW	220 MW	7200 MW
220 W	7200 W	240 kW	7500 kW	240 MW	7500 MW
240 W	7500 W	250 kW	8000 kW	250 MW	8000 MW
250 W	8000 W	300 kW		300 MW	

Note: For reactive power and apparent power, read 'W' in the above table as 'var' and 'VA' respectively.

6. Others

6.3. Measuring Item

The following table shows measuring items.

○: Measurement display is possible. —: Measurement display is not possible. Inst: Instantaneous value

Measuring item		Measurement display item											Communication		
		3-phase 4-wire system			3-phase 3-wire system (3CT)			3-phase 3-wire (2CT)/1-phase 3-wire system			1-phase 2-wire system				
		Inst	Max	Min	Inst	Max	Min	Inst	Max	Min	Inst	Max		Min	
Current	1-phase	○	○	○	○	○	○	○	○	○	○	○	○	○	○ Note3
	2-phase	○	○	○	○	○	○	○	○	○					
	3-phase	○	○	○	○	○	○	○	○	○					
	AVG	○	○	○	○	○	○	○	○	○					
	N-phase	○	○	○											
Current demand	1-phase	○	○	○	○	○	○	○	○	○	○	○	○		
	2-phase	○	○	○	○	○	○	○	○	○					
	3-phase	○	○	○	○	○	○	○	○	○					
	AVG	○	○	○	○	○	○	○	○	○					
	N-phase	○	○	○											
Voltage	1N-phase	○	○	○											
	2N-phase	○	○	○											
	3N-phase	○	○	○											
	AVG (L-N)	○	○	○											
	12-phase	○	○	○	○	○	○	○	○	○	○	○	○		
	23-phase	○	○	○	○	○	○	○	○	○					
	31-phase	○	○	○	○	○	○	○	○	○					
	AVG (L-L)	○	○	○	○	○	○	○	○	○					
Active power	1-phase	○	○	○											
	2-phase	○	○	○											
	3-phase	○	○	○											
	Σ	○	○	○	○	○	○	○	○	○	○	○	○		
Reactive power	1-phase	○	○	○											
	2-phase	○	○	○											
	3-phase	○	○	○											
	Σ	○	○	○	○	○	○	○	○	○	○	○	○		
Apparent power	1-phase	○	○	○											
	2-phase	○	○	○											
	3-phase	○	○	○											
	Σ	○	○	○	○	○	○	○	○	○	○	○	○		
Power factor	1-phase	○	○	○											
	2-phase	○	○	○											
	3-phase	○	○	○											
	Σ	○	○	○	○	○	○	○	○	○	○	○	○		
Frequency		○	○	○	○	○	○	○	○	○	○	○	○		
Harmonic current Note1	RMS value	1-phase	○			○			○			○	○		
		2-phase	○	Max Phase		○	Max Phase		○	Max Phase					
		3-phase	○			○			○						
		N-phase	○	○											
	Distortion ratio	1-phase	○			○			○			○			
		2-phase	○			○			○						
		3-phase	○			○			○						
		N-phase	-												
Harmonic voltage Note1	RMS value	1N-phase	○												
		2N-phase	○												
		3N-phase	○												
		12-phase				○			○			○			
		23-phase				○			○						
	Distortion ratio	1N-phase	○	Max Phase											
		2N-phase	○												
		3N-phase	○												
					○	Max Phase		○	Max Phase		○	○			
					○			○							
Active energy		Imported		○		○		○		○		○			
		Exported		○		○		○		○		○			
Reactive energy	2 quadrant	Positive Note2		○		○		○		○		○			
		Negative Note2		○		○		○		○		○			
	4 quadrant	Imported lag		○		○		○		○		○			
		Imported lead		○		○		○		○		○			
		Exported lag		○		○		○		○		○			
		Exported lead		○		○		○		○		○			
Apparent energy		Imported + Exported		○		○		○		○		○			
Operating time		1		○		○		○		○		○			
		2		○		○		○		○		○			
Phase angle Note4		○			○			○			○				

6. Others

6.3. Measuring Item

Note1: For harmonics, the total RMS value and total distortion ratio are measured.

Note2: Reactive energy (imported) represents a positive value, which is imported lag + exported lead.

Reactive energy (exported) represents a negative value, which is imported lead + exported lag.

Note3: For the measuring items monitored by communication function, refer to the user's manual of each communication function.

Note4: The phase angle can be measured only with the support function for determining incorrect wiring.

Note5: For 1-phase 3-wire system, the phases of measuring items are read as the following table.

Phase wire system	1-phase	2-phase	3-phase	12-phase	23-phase	31-phase
1-phase 3-wire (1N2)	1-phase	N-phase	2-phase	1N-phase	2N-phase	12-phase
1-phase 3-wire (1N3)	1-phase	N-phase	3-phase	1N-phase	3N-phase	13-phase

6. Others

6.4. Instrument Operation

■ The instrument operation in other than operating mode

Situation	Measurement	Display
For a few seconds just after turning on auxiliary power *The backlight is lit and the LCD is not lit.	Not measure	Not display
In the setting mode In the setting confirmation mode In the password protection screen	The action is the same in the operating mode.	Not display a measured value
Under power failure	Not measure	Not display

■ The instrument operation under input

Measuring element	Instrument action	
Current (A) Current demand (DA)	The CT secondary current setting is 5 A. When input current is below 0.005 A (0.1%), 0 A is displayed. The CT secondary current setting is 1 A. When input current is below 0.005 A (0.5%), 0 A is displayed.	When the upper limit of display range (9999) is exceeded, the upper limit (9999) is displayed.
Voltage (V)	When input voltage (Line voltage) is below 11 V, 0 V is displayed. •For 1-phase 3-wire system, when the voltage between P1 and P3 is below 22 V, 0 V is displayed. •For 3-phase 4-wire system, when phase voltage is below 11 V or line voltage is below 19 V, 0 V is displayed.	When the upper limit of display range (9999) is exceeded, the upper limit (9999) is displayed.
Active power (W) Reactive power (var) Apparent power (VA)	•When each of three phases of current is 0 A or when each of three phases of voltage is 0 V, 0W, 0 var, and 0 VA are displayed. •When current N-phase is 0 A or when voltage N-phase is 0 V, 0 W, 0 var, and 0 VA are displayed for each N-phase.	When the upper limit of display range (9999) is exceeded, the upper limit (9999) is displayed.
Power factor (PF)	•When each of three phases of current is 0 A or when each of three phases of voltage is 0 V, 1.0 is displayed. •When current N-phase is 0 A or when voltage N-phase is 0 V, 1.0 is displayed for each N-phase.	
Frequency (Hz)	•When voltage 1-phase is low voltage, - - - - is displayed. Apply a voltage above approximately 22 V.	When frequency is below 44.5 Hz and above 99.5 Hz, - - - - is displayed.
Harmonic current	For RMS value measurement: •When current is 0 A, 0 A is displayed. (for each phase) •When voltage 1-phase is 0 V or when frequency is below 44.5 Hz, - - - - is displayed for every phase.	For distortion ratio (content rate) measurement: •When harmonic current 1 st is 0 A, 0 A is displayed. (for each phase) •When voltage 1-phase is 0 V or when frequency is below 44.5 Hz, - - - - is displayed for every phase.
Harmonic voltage	For RMS value measurement: •When voltage is 0 V, 0 V is displayed. (for each phase) •When voltage 1-phase is 0 V or when frequency is below 44.5 Hz, - - - - is displayed for every phase.	For distortion ratio (content rate) measurement: •When voltage is 0 V, - - - - is displayed. (for each phase) •When voltage 1-phase is 0 V or when frequency is below 44.5 Hz, - - - - is displayed for every phase.
Operating Time	When the count exceeds 999999-hour, it is fixed at 999999-hour.	

Note1: Current/voltage/active power input represents input to the instrument. It does not input to the primary side of VT/CT.

Note2: The expression of 'When current is 0 A' includes the case when the measured value described in the item of Current (A) is 0 A.

Note3: The expression of 'When voltage is 0 V' includes the case when the measured value described in the item of Voltage (V) is 0 V.

Note4: Use the instrument within the rating of the instrument.

6. Others

6.5. Troubleshooting

If you observe abnormal sound, odor, smoke, or heat generation from the instrument, turn off the power at once.

In addition, if you consider sending the instrument in for repair, check the following points before it.

	Situation	Possible cause	Solution
Display	The display does not light up.	Auxiliary power is not applied to MA and MB terminals.	Apply auxiliary power supply.
	When auxiliary power is applied, the display does not light up for a short time.	This is not an error. For a few seconds after charging auxiliary power, the internal circuit is being initialized.	Use it as it is.
	The backlight does not light up.	The backlight may be set to 'auto off (Auto).' *When it lights up by pressing any operation button, it is set to 'auto off.'	When it is set to auto off, it automatically goes off in 5 minutes. Use it as it is or change the setting to 'ON (Hold).' For details, refer to 3.5 .
	The display becomes black.	It may become black due to static electricity.	It will go off after a while.
	The 'End' display remains.	It is in the setting mode.	Press the SET button.
Measurement error	The current and voltage errors are large.	The settings for VT/Direct voltage and CT primary current may be incorrect.	Check the settings for VT/Direct voltage and CT primary current.
	Current and voltage are correct, but active power and power factor errors are large.	The wiring for VT/CT and the instrument may be incorrect.	Check the wiring for VT/CT and the instrument.
	The power factor error is large.	If input current is smaller than the rating, the error will become large. (approximately 5% or less of the rated current)	This is not an error. Use it as it is, or if the error is troublesome, change the CT according to the actual current.
	The displayed active power is different from that calculated by multiplying the displayed current, voltage, and power factor.	If the current and voltage AC waveforms distort due to harmonics, the value will not be the same as the calculated value. (For current waveforms without harmonics, the calculated value matches with the displayed value.)	Use the instrument as it is.
	The total harmonic RMS value of harmonic current is quite different from the current value.	The distortion ratio (content rate) is well over 100%. (For measurement of inverter secondary side output)	Check the measured item.
	The current value measured by this instrument is different from that measured by other measuring instrument, such as a clamp meter. The difference exceeds an acceptable level.	If the comparative measuring instrument uses the average value method, the AC waveform will distort due to harmonics, and the error of the comparative instrument will become large. (This instrument uses the RMS value method.)	Compare with a current value of a measuring instrument that uses the RMS value method.
	On the Max/Min value screen, the present value is displayed beyond the range of maximum and minimum values.	During the starting current delay time, the maximum value is not updated. Therefore, the displayed present value may exceed the maximum value.	Use the instrument as it is.
Operation	In the setting mode, setting change is not possible.	When SET blinks at the bottom left of the screen, it is in the setting confirmation mode. Therefore, setting change is not possible.	Enter the setting mode to change the settings.
	When the screen enters the setting mode, the PASS 0000 display appears	The password protection is enabled.	Enter the password you set up. The factory default password is '0000.' For details, refer to 5.2.7 Password Protection Setting .
Others	Maximum and minimum values change.	The values will be cleared if you change a setting such as phase wire system, VT/Direct voltage, or CT primary current.	It is necessary to record the data before changing the setting.
	The settings you have not changed change.	If you change a setting such as phase wire system, VT/Direct voltage, or CT primary current, some items will return to the default settings.	Set up the item, where settings have returned to the default, again. For details, refer to 3.11 Initialization of Related Items by Changing a Setting
	When Max/Min value or active energy values are cleared, the PASS 0000 display appears	The password protection is enabled.	Enter the password you set up. The factory default password is '0000.' For details, refer to 5.2.7 Password Protection Setting .
Communication	COM on the LCD blinks. (ON for 0.25 second/OFF for 0.25 second)	Communication errors may be occurring in MODBUS RTU such as register address error or communication rate setting error	Check the register address and communication settings. If a correct MODBUS RTU communication message is received, COM will light up.

7. Installation

7.1. Dimensions

■ ME96SSEB-MB

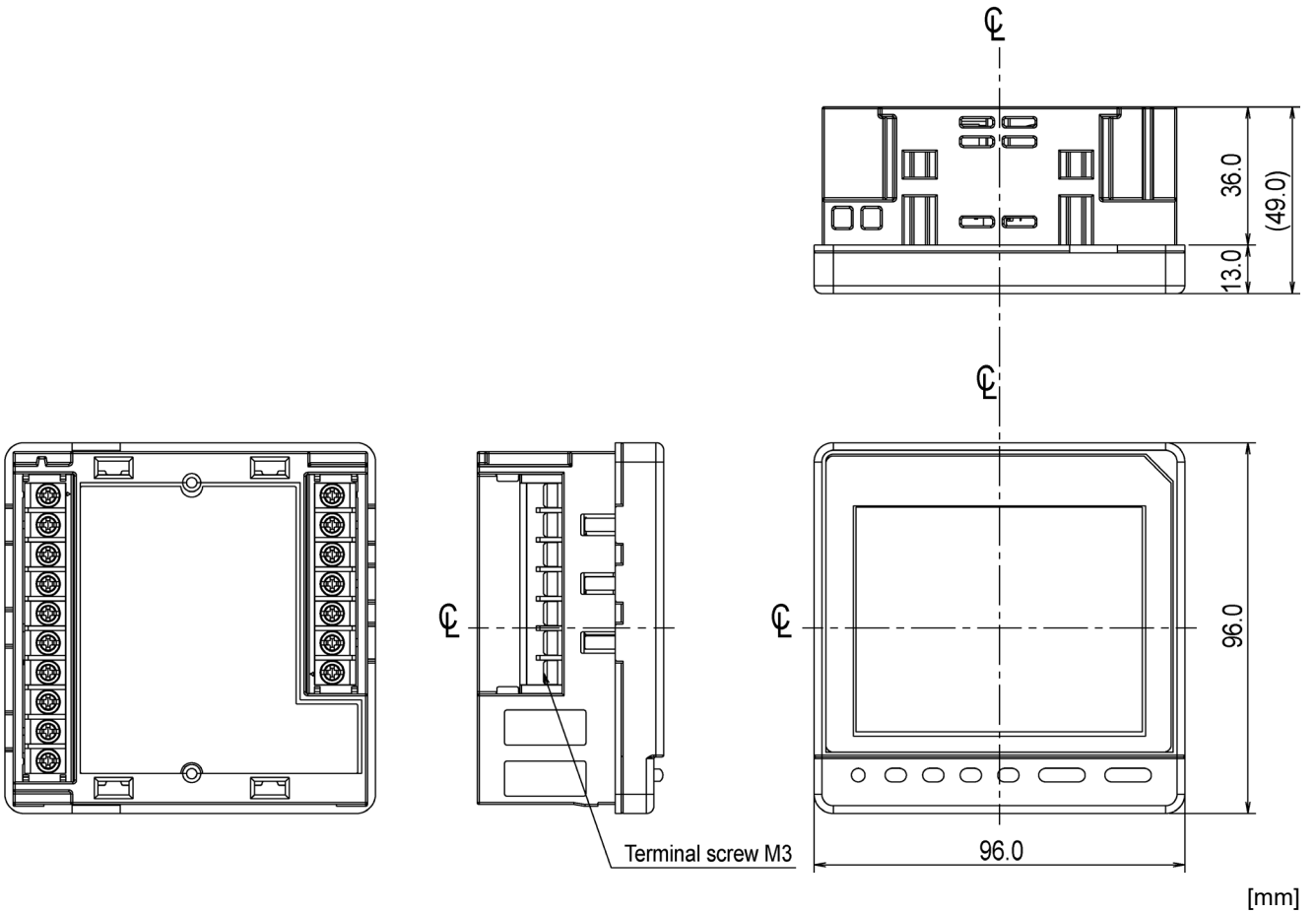

7. Installation

7.2. How to Install

7.2.1. Mounting Hole Dimensions

The right figure shows the hole drilling dimensions of the panel. The instrument can be installed on a panel with a thickness of 1.6 mm to 4.0 mm.

7.2.2. Mounting Position

The contrast of LCD display changes depending on the angle of view. Install the instrument in a location where you can easily see it.

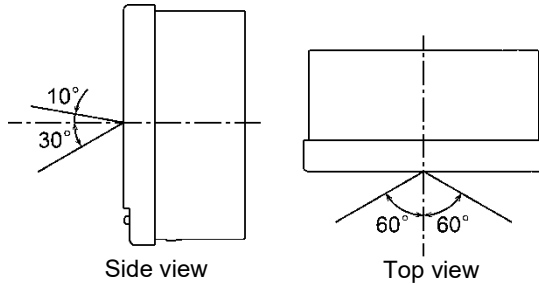

* The specified angles are evaluated at +23°C.

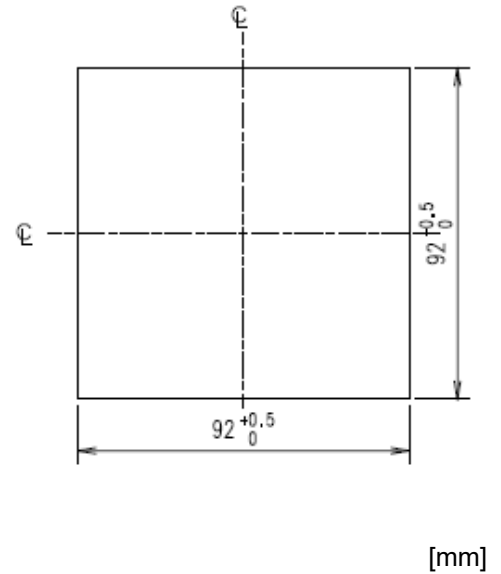

7.2.3. Mounting and Fixing

You will install the instrument on a panel according to the following procedure.

- ① Install the two attachment lugs on the top and bottom of the unit.
- ② Tighten the screws of the attachment lugs to fix them to the panel.

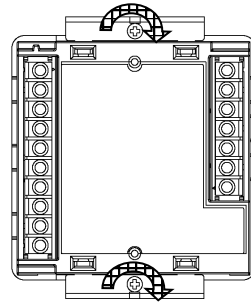
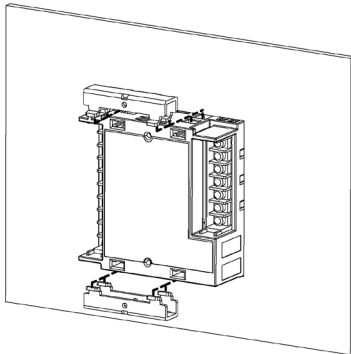

The mounting screw type: M3

Note

To prevent damage to the panel and screws, do not overtighten the screws. Tighten the two screws evenly. The recommended torque for this product is 0.3 N•m to 0.5 N•m (about half the normal torque).

Note

Protection sheet

The protection sheet is attached to the LCD display to prevent scratches on the display during installation. Before starting operation, remove the sheet. When you remove the sheet, the LCD display may light up due to static electricity generation. However, this is not abnormal. After a while, the lighting will go off due to self-discharge.

Mounting position

When you install the instrument on the edge of the panel, check the work space for wiring to determine the mounting position.

7. Installation

7.3. How to Connect Wiring

7.3.1. Specifications on the Applicable Electrical Wire

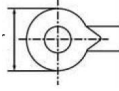
Parts	Screw type	Wire for use	Tightening torque
The terminals of the unit: <ul style="list-style-type: none">• Auxiliary power• Voltage input• Current input• MODBUS RTU communication	M3	<ul style="list-style-type: none">• Used with crimp-type terminals: AWG 26 to 14• *Two-wire connection is possible. Applicable crimp-type terminals: For M3 screw with an outer diameter of 6.0 mm or less. Outer diameter 	0.5 N·m

7.3.2. Wiring of the Unit

Be sure to securely tighten the terminal screws to the terminal block.

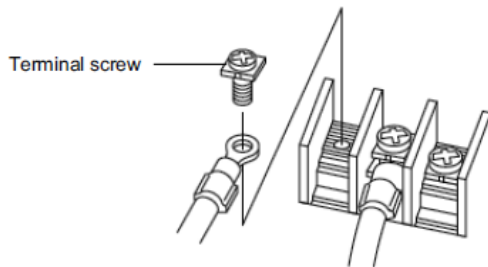

	<ul style="list-style-type: none">• Do not connect three or more electric wires to one terminal. This can cause heat generation or a fire due to imperfect contact.• If you use a bare crimp-type terminal, you should secure a necessary insulation distance using an insulation tube not to expose the charging part for prevention of electric shock and short circuits.
---	--

7.3.3. Check the connection

After wiring, check the following points:

- The electric wires are securely connected.
- There is no wrong wiring.

7. Installation

7.3. How to Connect Wiring

CAUTION

Do not work under live wires

Do not work for wiring under live line conditions.
It may cause an electric shock, burn injury, burnout of the instrument, or a fire.
We recommend that you install protection fuses for VT and auxiliary power unit.

Do not open the secondary side of CT circuit

Connect the CT secondary-side signal correctly to the terminal for CT.
If the CT were incorrectly connected or if the CT secondary side were open, it could result in a high voltage generation at the CT secondary side and insulation breakdown in the CT secondary winding. It might cause burnout.

Do not short the secondary side of VT circuit

Connect the VT secondary-side signal correctly to the terminal for VT.
If the VT were incorrectly connected or if a short occurred at the VT secondary side, an overcurrent would flow through the VT secondary side and it would cause burnout in the VT secondary winding. The burnout of the secondary winding would lead to insulation breakdown in the secondary winding. Finally, it might cause short circuit between phases.

Securely connect to the connection terminal

Connect electrical wires properly to the connection terminal.
Otherwise, heat generation or measurement errors may occur.

Do not forget to connect wiring of 'C₁', 'C₂' and 'C₃'

When a common wire is used for L side (load side) of the CT circuit of a 3-phase instrument, it is necessary to short-circuit the C₁, C₂, and C₃ terminals of the instrument.

Do not use improper electrical wires

Be sure to use an appropriate size wire compatible with the rated current and voltage.
The use of inappropriate size wire may cause a fire.

Do not pull connecting wires with a strong force

If you pulled the terminal wires with a strong force, the input terminal part might come off. (Tensile load: 39.2N or less)

Do not apply an abnormal voltage.

If the pressure test of a high-pressure device is performed, ground the input lines of CT and VT secondary sides in order to prevent damage to the instrument. If a high voltage of AC 2000 V were applied to the instrument for over one minute, it might cause a failure.

Do not connect to Non-Connection (NC) terminal.

Do not connect to the Non-Connection (NC) terminal for the purpose of relay.

Supply voltage properly to the auxiliary power source.

Supply proper voltage to the auxiliary power terminal.
If an improper voltage were applied, it might cause a failure of the instrument or a fire.

7. Installation

7.4. Wiring Diagram

■ Rated voltage for each phase/wire system

Phase/Wire	Connection	Rated voltage	Figure
3-phase 4-wire	Star	max 277 V AC (L-N) /480 V AC (L-L)	Figure 1
3-phase 3-wire	Delta	max 220 V AC (L-L)	Figure 2
	Star	max 440 V AC (L-L)	Figure 3
1-phase 3-wire	—	max 220 V AC (L-N) /440 V AC (L-L)	Figure 4
1-phase 2-wire *1	Delta	max 220 V AC (L-L)	Figure 5
	Star	max 440V AC (L-L)	Figure 6

Note1: The circuit derived from the 3-phase 3-wire delta connection and the 1-phase 2-wire transformer circuit have the maximum rating of 220 V AC.
The circuits derived from the 3-phase 4-wire and 3-phase 3-wire star connections and 1-phase 3-wire connection have the maximum rating of 440 V AC.

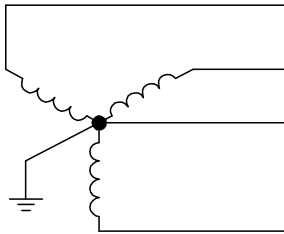

Fig.1. 3-phase 4-wire(star)

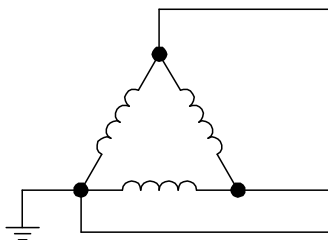

Fig.2. 3-phase 3-wire(delta)

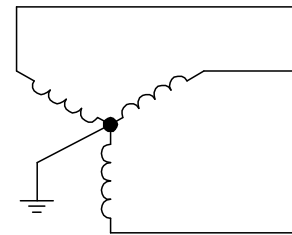

Fig.3. 3-phase 3-wire(star)

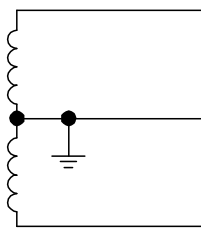

Fig.4. 1-phase 3-wire

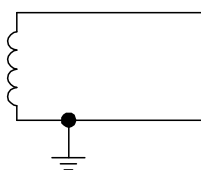

Fig.5. 1-phase 2-wire(delta)

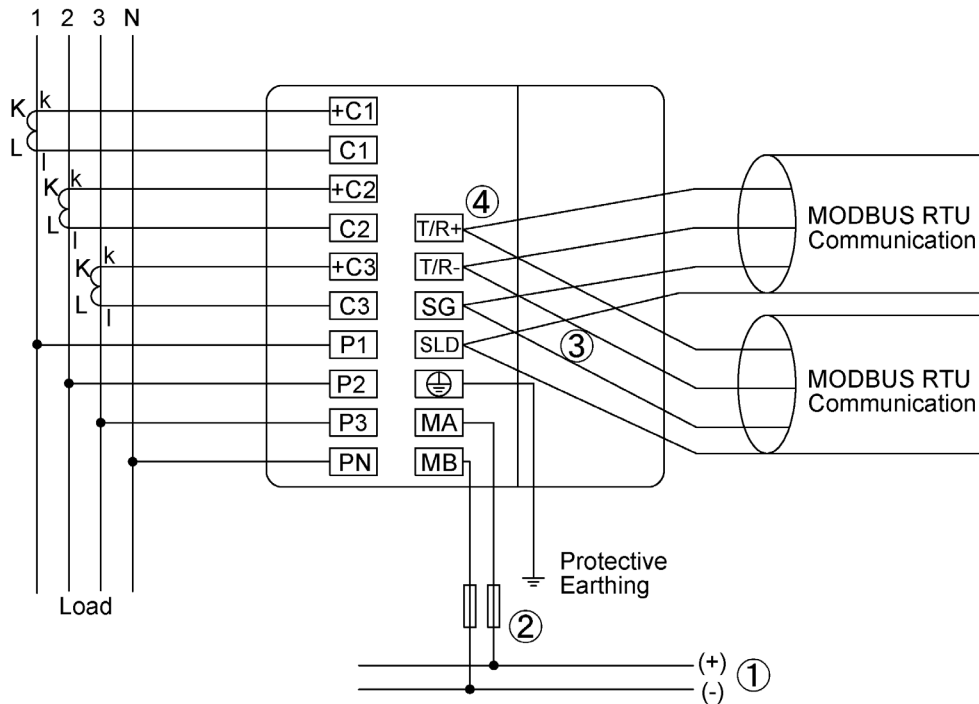

Fig.6. 1-phase 2-wire(star)

7. Installation

7.4. Wiring Diagram

■ 3-phase 4-wire system, direct input



①Auxiliary power supply

100 to 240 V AC or 100 to 240 V DC

②Fuse (recommendation)

Rated current: 0.5 A, Rated breaking capacity: 250 V AC 1,500 A / 250 V DC 1,500 A (a UL certified product)

③If MODBUS RTU devices do not have the SG terminal, the wiring between SG terminals is not necessary.

④Install 120-Ohm terminating resistors between terminals 'T/R+' and 'T/R-' for devices at both ends of MODBUS RTU communication line.

*Note1: For low voltage circuits, it is not necessary to ground the VT and CT secondary sides.

■ 3-phase 4-wire system, with VT

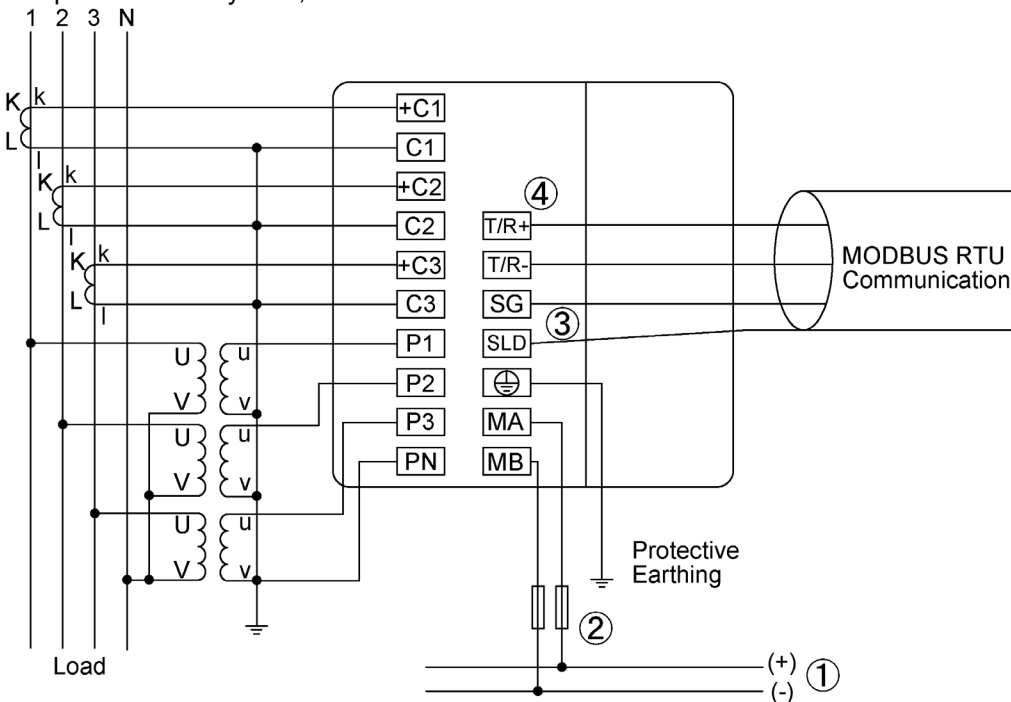

①Auxiliary power supply

100 to 240 V AC or 100 to 240 V DC

②Fuse (recommendation)

Rated current: 0.5 A, Rated breaking capacity: 250 V AC 1,500 A / 250 V DC 1,500 A (a UL certified product)

③If MODBUS RTU devices do not have the SG terminal, the wiring between SG terminals is not necessary.

④Install 120-Ohm terminating resistors between terminals 'T/R+' and 'T/R-' for devices at both ends of MODBUS RTU communication line.

*Note1: For low voltage circuits, it is not necessary to ground the VT and CT secondary sides.

7. Installation

7.4. Wiring Diagram

■ 3-phase 3-wire system, direct input, 2CT

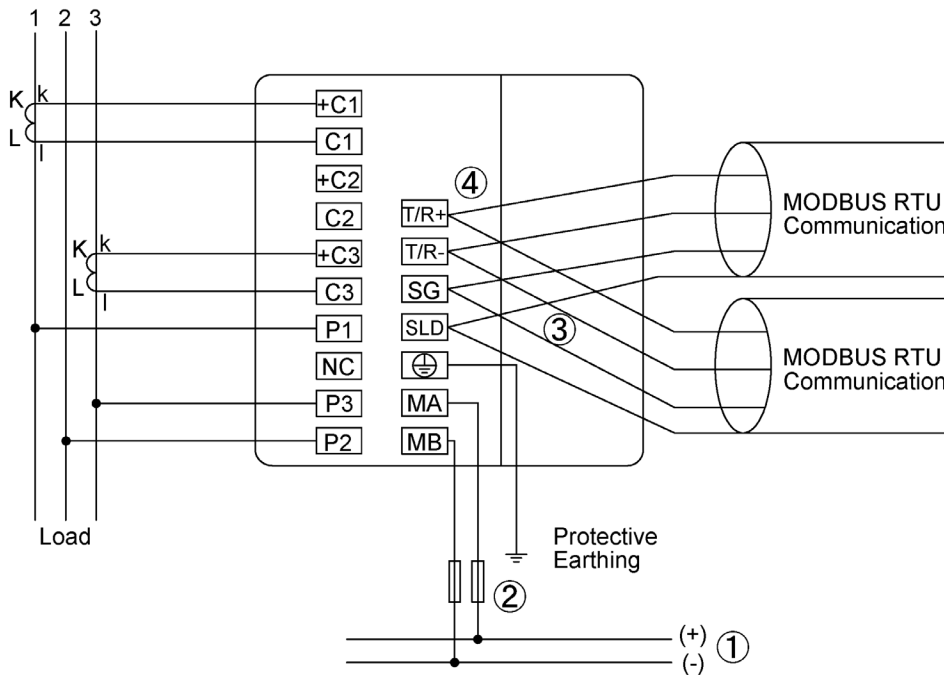

① Auxiliary power supply

100 to 240 V AC or 100 to 240 V DC

② Fuse (recommendation)

Rated current: 0.5 A, Rated breaking capacity: 250 V AC 1,500 A / 250 V DC 1,500 A (a UL certified product)

③ If MODBUS RTU devices do not have the SG terminal, the wiring between SG terminals is not necessary.

④ Install 120-Ohm terminating resistors between terminals 'T/R+' and 'T/R-' for devices at both ends of MODBUS RTU communication line.

*Note1: For low voltage circuits, it is not necessary to ground the VT and CT secondary sides.

*Note2: Do not connect the NC terminal.

■ 3-phase 3-wire system, with VT, 3CT

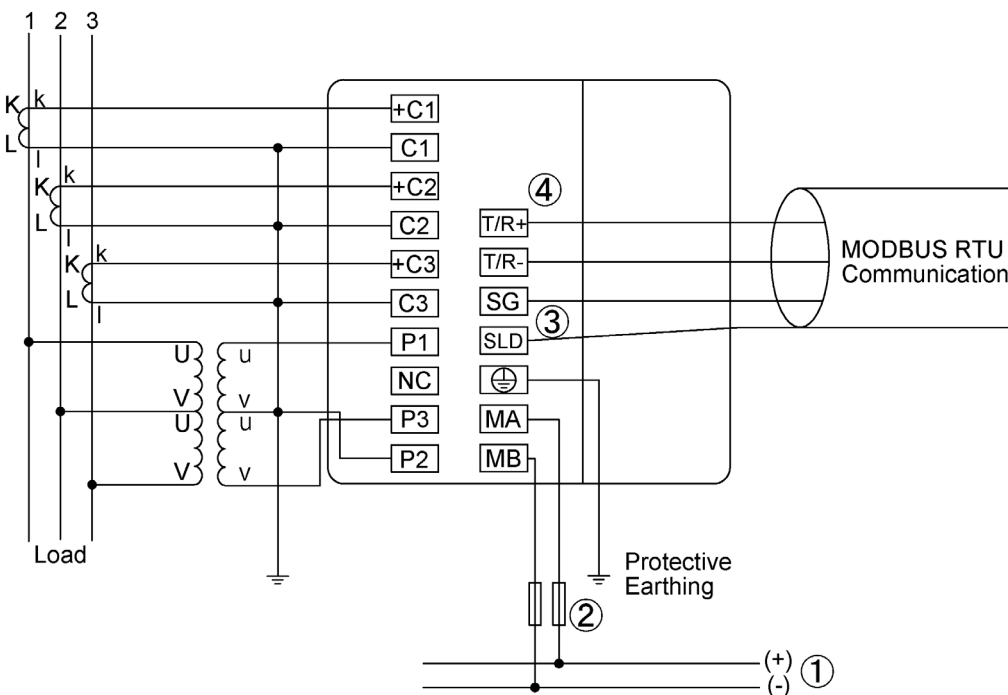

① Auxiliary power supply

100 to 240 V AC or 100 to 240 V DC

② Fuse (recommendation)

Rated current: 0.5 A, Rated breaking capacity: 250 V AC 1,500 A / 250 V DC 1,500 A (a UL certified product)

③ If MODBUS RTU devices do not have the SG terminal, the wiring between SG terminals is not necessary.

④ Install 120-Ohm terminating resistors between terminals 'T/R+' and 'T/R-' for devices at both ends of MODBUS RTU communication line.

*Note1: For low voltage circuits, it is not necessary to ground the VT and CT secondary sides.

*Note2: Do not connect the NC terminal.

7. Installation

7.4. Wiring Diagram

■ 1-phase 3-wire system

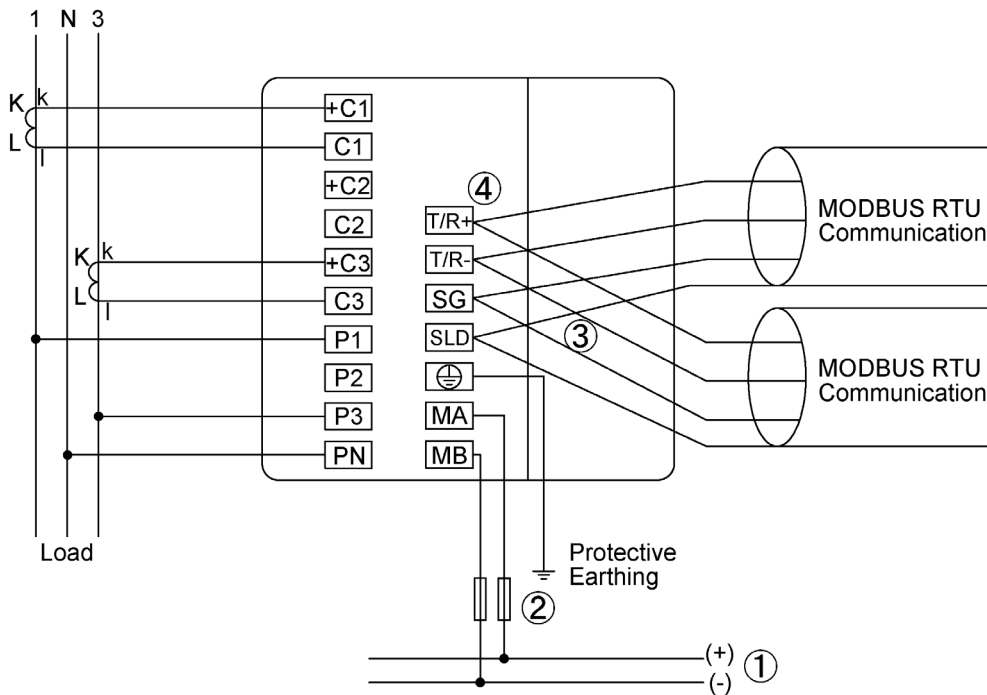

① Auxiliary power supply

100 to 240 V AC or 100 to 240 V DC

② Fuse (recommendation)

Rated current: 0.5 A, Rated breaking capacity: 250 V AC 1,500 A / 250 V DC 1,500 A (a UL certified product)

③ If MODBUS RTU devices do not have the SG terminal, the wiring between SG terminals is not necessary.

④ Install 120-Ohm terminating resistors between terminals 'T/R+' and 'T/R-' for devices at both ends of MODBUS RTU communication line.

*Note1: For low voltage circuits, it is not necessary to ground the VT and CT secondary sides.

*Note2: Do not connect the NC terminal.

■ 1-phase 2-wire system, with VT

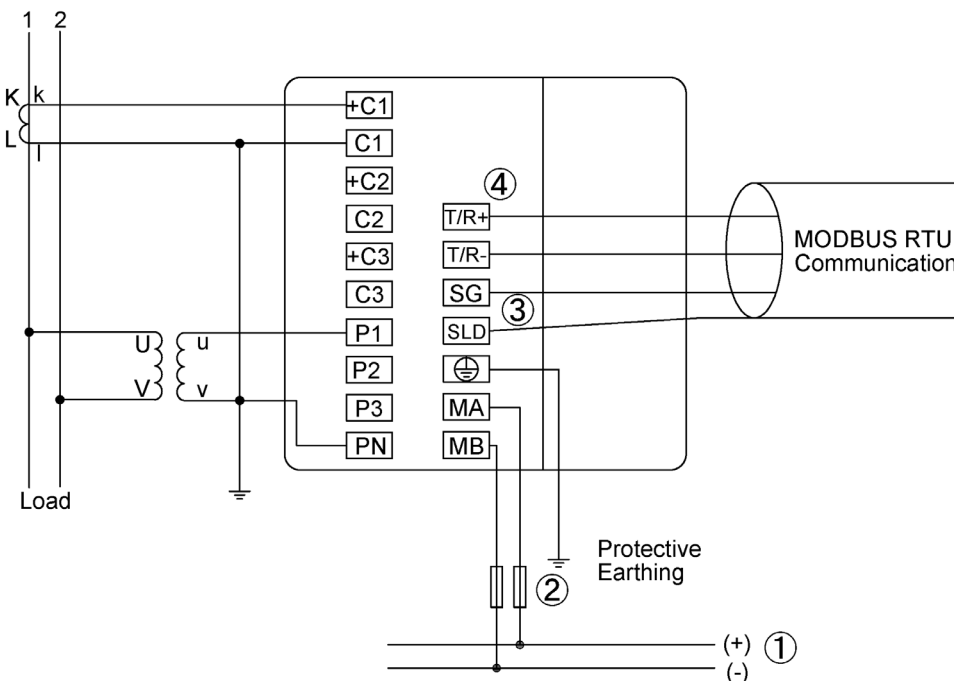

① Auxiliary power supply

100 to 240 V AC or 100 to 240 V DC

② Fuse (recommendation)

Rated current: 0.5 A, Rated breaking capacity: 250 V AC 1,500 A / 250 V DC 1,500 A (a UL certified product)

③ If MODBUS RTU devices do not have the SG terminal, the wiring between SG terminals is not necessary.

④ Install 120-Ohm terminating resistors between terminals 'T/R+' and 'T/R-' for devices at both ends of MODBUS RTU communication line.

*Note1: For low voltage circuits, it is not necessary to ground the VT and CT secondary sides.

*Note2: Do not connect the NC terminal.

7. Installation

7.4. Wiring Diagram

For Input

Note	<ol style="list-style-type: none">1. The voltage input terminals of 3-phase 3-wire system are different from those of other systems.2. If the VT and CT polarities are incorrect, measurement will not be correctly executed.3. Do not wire the NC terminal.4. For low voltage, it is not necessary to ground the VT and CT secondary sides.5. Be sure to ground the earth terminal (⊕) to use. The ground resistance is 100 ohm or less. Improper ground may cause a malfunction.
-------------	--

For MODBUS RTU Communication

Note	<ol style="list-style-type: none">1. Use a shielded twisted pair cable for transmission signal line. *For recommended cables, refer to 8.3 MODBUS RTU Communication Specifications.2. Install 120-Ohm terminating resistors between terminals 'T/R+' and 'T/R-' for devices at both ends of MODBUS RTU communication line.3. Use wires as thick as possible to ground for low impedance.4. The transmission signal lines of MODBUS RTU communication must not be placed close to or bound together with high voltage lines.5. Perform one point grounding for the SLD terminal.
-------------	--

8. Specifications

8.1. Product Specifications

Type		ME96SSEB-MB	
Phase wire system		3-phase 4-wire, 3-phase 3-wire (3CT, 2CT), 1-phase 3-wire, 1-phase 2-wire (common use)	
Rating	Current	5 A AC, 1 A AC (common use)	
	Voltage	3-phase 4-wire: max 277/480 V AC 3-phase 3-wire: (DELTA) max 220 V AC, (STAR) max 440 V AC 1-phase 3-wire: max 220/440 V AC 1-phase 2-wire: (DELTA) max 220 V AC, (STAR) max 440 V AC	
	Frequency	50 Hz or 60 Hz (common use)	
Item		Measuring Item	Class
Measuring element	Current (A)	A1, A2, A3, AN, A _{AVG}	±0.5%
	Current demand (DA)	DA1, DA2, DA3, DAN, DA _{AVG}	
	Voltage (V)	V12, V23, V31, V _{AVG} (L-L), V1N, V2N, V3N, V _{AVG} (L-N)	
	Active power (W)	W1, W2, W3, ΣW	
	Reactive power (var)	var1, var2, var3, Σvar	
	Apparent power (VA)	VA1, VA2, VA3, ΣVA	
	Power factor (PF)	PF1, PF2, PF3, ΣPF	
	Frequency (Hz)	Hz	±0.2%
	Active energy (Wh)	Imported, Exported	Class 0.5S (IEC62053-22)
	Reactive energy (varh)	Imported lag, Imported lead, Exported lag, Exported lead	Class 1S (IEC62053-24)
	Apparent energy (VAh)	Imported + Exported	±2.0%
	Harmonic current (HI)	Total	±2.0%
	Harmonic voltage (HV)	Total	
Operating time (h)	Operating time 1, Operating time 2	(Reference)	
Measuring method	Instantaneous value	A, V: RMS value calculation; W, var, VA, Wh, varh, VAh: Digital multiplication; PF: Power ratio calculation; Hz: Zero-cross; HI, HV: FFT	
	Demand value	DA: Thermal type calculation	
Display	Display type		LCD with LED backlight
	Number of display digits or segments	Digital section	First to third line indication: 4 digits, Fourth line display: 6 digits A, DA, V, W, var, VA, PF: 4 digits; Hz: 3 digits; Wh, varh, VAh: 9 digits (6-digit or 12-digit is also possible.); Harmonic distortion ratio/content rate: 4 digits; Harmonic RMS value: 4 digits; Operating time: 6 digits
			Display update time interval
Communication		MODBUS RTU communication	
Connectable optional plug-in module		Cannot connect optional module	
Power interruption backup		Non-volatile memory is used (Item: Setup value, Max/Min value, Active energy, Reactive energy, Apparent energy, Operating time)	
VA consumption	Voltage circuit	0.1 VA/phase (at 110 V AC), 0.2 VA/phase (at 220 V AC), 0.4 VA/phase (at 440 V AC)	
	Current circuit	0.1 VA / phase	
	Auxiliary power circuit	4 VA (at 110 V AC), 5 VA (at 220 V AC), 3 W (at 100 V DC)	
Auxiliary power		100 to 240 V AC (±15%) 50 to 60 Hz, 100 to 240 V DC (-30% +15%)	
Weight		0.3 kg	
Dimensions W × H × D [protrusion from cabinet]		96 × 96 × 36 mm (depth of meter from housing mounting flange) [13 mm]	
Mounting method		Embedded type	
Operating temperature/humidity		-5°C to +55°C (average daily temperature: 35°C or less), 0 to 85% RH, Non-condensing	
Storage temperature/ humidity		-25°C to +75°C (average daily temperature: 35°C or less), 0 to 85% RH, Non-condensing	

Note1: The class represents the ratio to the rated value (100%).

Note2: For measurement where the harmonic distortion ratio (content rate) is 100% or more, the class can exceed ±2.0%.

Note3: Harmonic current cannot be measured without voltage input.

PMD characteristics (specified by IEC61557-12)

Type of characteristic	Characteristic value	Other complementary characteristic
Power quality assessment function according to 4.3	PMD- II	-
Classification of PMD according to 4.4	SD	-
Temperature	K55	-
Humidity + altitude	Standard conditions	-
Active power or active energy function (If function available) performance class	0.5	-

8. Specifications

8.2. Compatible Standards

Electromagnetic Compatibility	
Emissions	
Radiated Emission	EN61326-1/ EN 55011/CISPR 11, FCC Part15 Subpart B Class A
Conducted Emission	EN61326-1/ EN 55011/CISPR 11 FCC Part15 Subpart B Class A
Harmonics Measurement	EN61000-3-2
Flicker Meter Measurement	EN61000-3-3
Immunity	
Electrostatic discharge Immunity	EN61326-1, EN IEC 61000-6-2/EN61000-4-2
Radio Frequency Electromagnetic field Immunity	EN61326-1, EN IEC 61000-6-2/EN61000-4-3
Electrical Fast Transient/Burst Immunity	EN61326-1, EN IEC 61000-6-2/EN61000-4-4
Surge Immunity	EN61326-1, EN IEC 61000-6-2/EN61000-4-5
Conducted Disturbances, Induced By Radio Frequency Fields Immunity	EN61326-1, EN IEC 61000-6-2/EN61000-4-6
Power Frequency Magnetic Field Immunity	EN61326-1, EN IEC 61000-6-2/EN61000-4-8
Voltage Dips and Short Interruptions	EN61326-1, EN IEC 61000-6-2/EN61000-4-11

Safety	
Europe	CE, as per EN61010-1: 2010 (3 rd Edition)
U.S. and Canada	UL, cUL Recognized as per UL61010-1: 2012 (3 rd Edition) IEC61010-1: 2010 (3 rd Edition) CCN:PICQ2/8 (*1)
Installation Category	III
Measuring Category	III
Pollution Degree	2

*1 : PICQ2/8 is intended to be placed in an industrial control panel or similar type of enclosure.

The devices covered under this category are incomplete in certain constructional features or restricted in performance capabilities and are intended for use as components of complete equipment submitted for investigation rather than for direct separate installation in the field. The final acceptance of the component is dependent upon its installation and use in complete equipment submitted to UL. See "UL product iQ (UL certified product search platform)" for details.

8.3. MODBUS RTU Communication Specifications

Item	Specifications
Physical interface	RS-485 2wires half duplex
Protocol	RTU mode
Transfer method	Start-stop synchronization
Transmission wiring type	Multi-point bus (either directly on the trunk cable, forming a daisy-chain)
Baud rate	2400, 4800, 9600, 19200, 38400 bps (Default is 19200 bps)
Data bit	8
Stop bit	1 or 2 (Default is 1)
Parity	ODD,EVEN or NONE (Default is EVEN)
Slave address	1 to 255 (FFh) (Default is 1, 0 is for broadcast mode) (248 to 255 are reserved)
Distance	1200 m
Max. number	31
Response time	1 s or less (time to response after query data is received)
Terminate	120 Ω 1/2 W
Recommended cable	Shielded twisted pair cable, AWG 24 to 14

■ Read the following document as well as this user' s manual.

- Electronic Multi-Measuring Instrument ME Series MODBUS Interface specifications (Ref. No. LSPM-0075)

8. Specifications

8.4. Setting Table (Factory Default Settings and Customer's Notes Settings)

Setting menu No.	Setting item	Factory default setting	Customer's notes	
1	1.1	Phase wire system	3P4 (3-phase 4-wire)	
	1.2	Display pattern	P01	
		1.2.1	Pattern P00	—
	1.3	VT/Direct voltage	no (Without VT)	
		1.3.1	Direct voltage	220/380 V
		1.3.2	VT secondary voltage	—
		1.3.3	VT primary voltage	—
1.4	CT secondary current	5 A		
	1.4.1	CT primary current	5 A	
1.7	Current demand time period	0 s		
2	2.2	MODBUS RTU address	1	
	2.2.1	MODBUS RTU baud rate	19.2 kbps	
		2.2.2	MODBUS RTU parity	EVEN (even)
		2.2.3	MODBUS RTU stop bit	1
3	3.1	Active/Reactive energy measurement	Combination I	
	3.2	Harmonics display	on (Display)	
4	4.1	Model display	(By model)	
	4.2	Version display	(By version)	
	4.3	Backlight brightness	3	
	4.4	Backlight Auto off/ON	Auto (Auto off)	
	4.5	Display update time	0.5 s	
5	5.1	Upper/Lower limit alarm item 1	non	
		5.1.1	Upper/Lower limit alarm value 1	—
	5.2	Upper/Lower limit alarm item 2	non	
		5.2.1	Upper/Lower limit alarm value 2	—
	5.3	Upper/Lower limit alarm item 3	non	
		5.3.1	Upper/Lower limit alarm value 3	—
	5.4	Upper/Lower limit alarm item 4	non	
		5.4.1	Upper/Lower limit alarm value 4	—
	5.5	Alarm delay time	—	
	5.6	Alarm reset method	—	
5.7	Backlight blinking during alarm	—		
5.8	Motor starting current delay function	oFF (Not display)		
	5.8.1	Motor starting current threshold	—	
	5.8.2	Motor starting current delay time	—	
8	8.1	Operating time display	oFF (Not display)	
	8.2	Operating time 1 count target	AUX (Auxiliary power)	
		8.2.1	Operating time 1 threshold	—
	8.3	Operating time 2 count target	AUX (Auxiliary power)	
		8.3.1	Operating time 2 threshold	—
8.4	IEC mode settings	oFF (Normal mode)		

9. Appendix

9.1. ME96SS Calculation Method (3-phase Unbalanced System with Neutral)

The following table shows general calculation definitions of electric energy measurement this instrument employs.

Item	Normal mode	IEC mode	Notes
RMS current in phase p	$I_p = \sqrt{\frac{\sum_{k=0}^{M-1} i_{pk}^2}{M}}$		
Calculated RMS neutral current	$I_N = \sqrt{\frac{\sum_{k=0}^{M-1} (i_{1k} + i_{2k} + i_{3k})^2}{M}}$		
Phase p to neutral RMS voltage	$V_p = \sqrt{\frac{\sum_{k=0}^{M-1} v_{pk}^2}{M}}$		
Phase p to phase g RMS voltage	$U_{pg} = \sqrt{\frac{\sum_{k=0}^{M-1} (v_{pk}^2 - v_{gk}^2)^2}{M}}$		
Active power for phase p	$P_p = \frac{1}{M} \cdot \sum_{k=0}^{M-1} (v_{pk} \times i_{pk})$		
Apparent power for phase p	$S_p = V_p \times I_p$		
Reactive power for phase p	$Q_p = Q_{p_{quad}} = \frac{1}{M} \cdot \sum_{k=0}^{M-1} (v_{pk-N/4} \times i_{pk})$	$Q_p = \sqrt{S_p^2 - P_p^2}$	For the sign, refer to 5.1.12.
Power factor for phase p	$PF_p = \frac{P_p}{\sqrt{P_p^2 + Q_p^2}}$	$PF_p = \frac{P_p}{S_p}$	For the sign, refer to 5.1.12.
Total active power	$P = \sum_{p=1}^{N_{ph}} P_p$		
Total reactive power	$Q = \sum_{p=1}^{N_{ph}} Q_p$		For the sign, refer to 5.1.12.
Total apparent power	$S = \sum_{p=1}^{N_{ph}} S_p$	$S = \sqrt{P^2 + Q^2}$	
Total power factor	$PF = \frac{P}{\sqrt{P^2 + Q^2}}$	$PF = \frac{P}{S}$	For the sign, refer to 5.1.12.

9. Appendix

9.2. A List of Examples for Incorrect Wiring Display

9.2.1. 3-phase 4-wire System

*The shaded parts indicate influential parts caused by incorrect wiring.
The dashed lines show incorrect wiring parts.

No.	Power Factor (Input)	Phase Angle Display						At balanced load ($V_{1N}=V_{2N}=V_{3N}$, $I_1=I_2=I_3$)									Connection (Note 1)																	
		Active Power Display			Voltage Display			Current Display			Voltage			Current			Connection																	
		$\angle V_{1N}$	$\angle V_{2N}$	$\angle V_{3N}$	$\angle I_1$	$\angle I_2$	$\angle I_3$	W_1	W_2	W_3	V_{1N}	V_{2N}	V_{3N}	I_1	I_2	I_3		1	2	3	N	1 side CT	2 side CT	3 side CT										
1	LEAD 0.707	0	120	240	315	75	195	$W_1=W_2=W_3$	$V_{1N}=V_{2N}=V_{3N}$	$I_1=I_2=I_3$	P1	P2	P3	PN	+C1-C1 Normal	+C2-C2 Normal	+C3-C3 Normal																	
	LEAD 0.866				330	90	210																											
	1.000				0	120	240																											
	LAG 0.866				30	150	270																											
	LAG 0.707				45	165	285																											
	LEAD 0.707				0	240	120												315	195	75	$W_1=W_2=W_3$	$V_{1N}=V_{2N}=V_{3N}$	$I_1=I_2=I_3$	P1	P3	P2	PN	+C1-C1 Normal	+C3-C3 Normal	+C2-C2 Normal			
	LEAD 0.866																		330	210	90													
	1.000																		240	120	0												240	120
	LAG 0.866																		30	270	150													
	LAG 0.707																		45	285	165													
LEAD 0.707	0	240	120	315				75	195	$W_1=W_2=W_3$	$V_{1N}=V_{2N}=V_{3N}$	$I_1=I_2=I_3$	P3	P2	P1	PN	+C3-C3 Normal	+C2-C2 Normal	+C1-C1 Normal															
LEAD 0.866				330				210	90																									
1.000				240				120	0												240												120	
LAG 0.866				30				270	150																									
LAG 0.707				45				285	165																									
LEAD 0.707				0	240	120	315	255	195												$W_1=$ Positive value $W_2=$ Negative value $W_3=$ Positive value	$V_{1N}=V_{2N}=V_{3N}$	$I_1=I_2=I_3$	P1	P2	P3	PN	+C1-C1 Normal	+C2-C2 Reverse	+C3-C3 Normal				
LEAD 0.866							330	270	210																									
1.000							0	120	240																							0	300	240
LAG 0.866							30	330	270																									
LAG 0.707							45	345	285																									
LEAD 0.707	0	120	240				135	75	195	$W_1=$ Negative value $W_2=$ Positive value $W_3=$ Positive value	$V_{1N}=V_{2N}=V_{3N}$	$I_1=I_2=I_3$	P1	P2	P3	PN	+C1-C1 Reverse	+C2-C2 Normal	+C3-C3 Normal															
LEAD 0.866							150	90	210																									
1.000							0	120	240																							180	120	240
LAG 0.866							210	150	270																									
LAG 0.707							225	165	285																									

9. Appendix

9.2. A List of Examples for Incorrect Wiring Display

9.2.1. 3-phase 4-wire System

No.	Power Factor (Input)	Phase Angle Display						At balanced load ($V_{1N}=V_{2N}=V_{3N}$, $I_1=I_2=I_3$)									Connection (Note 1)						
		$\angle V_{1N}$ $\angle V_{2N}$ $\angle V_{3N}$			$\angle I_1$ $\angle I_2$ $\angle I_3$			Active Power Display			Voltage Display			Current Display			Voltage			Current			Connection
		W_1	W_2	W_3	V_{1N}	V_{2N}	V_{3N}	I_1	I_2	I_3	1	2	3	N	1 side CT	2 side CT	3 side CT						
4	LEAD 0.707	0	120	240	315	75	15	W_1 =Positive value W_2 =Positive value W_3 =Negative value	$V_{1N}=V_{2N}=V_{3N}$	$I_1=I_2=I_3$	P1	P2	P3	PN	+C1-C1 Normal	+C2-C2 Normal	+C3-C3 Reverse	Reverse connection of 3 side CT					
	LEAD 0.866				330	90	30																
	1.000				0	120	60																
	LAG 0.866				30	150	90																
	LAG 0.707				45	165	105																
5	LEAD 0.707	0	120	240	135	255	195	W_1 =Negative value W_2 =Negative value W_3 =Positive value	$V_{1N}=V_{2N}=V_{3N}$	$I_1=I_2=I_3$	P1	P2	P3	PN	+C1-C1 Reverse	+C2-C2 Reverse	+C3-C3 Normal	Reverse connection of 1 side CT and 2 side CT					
	LEAD 0.866				150	270	210																
	1.000				180	300	240																
	LAG 0.866				210	330	270																
	LAG 0.707				225	345	285																
6	LEAD 0.707	0	120	240	315	255	15	W_1 =Positive value W_2 =Negative value W_3 =Negative value	$V_{1N}=V_{2N}=V_{3N}$	$I_1=I_2=I_3$	P1	P2	P3	PN	+C1-C1 Normal	+C2-C2 Reverse	+C3-C3 Reverse	Reverse connection of 2 side CT and 3 side CT					
	LEAD 0.866				330	270	30																
	1.000				0	300	60																
	LAG 0.866				30	330	90																
	LAG 0.707				45	345	105																
7	LEAD 0.707	0	120	240	135	75	15	W_1 =Negative value W_2 =Positive value W_3 =Negative value	$V_{1N}=V_{2N}=V_{3N}$	$I_1=I_2=I_3$	P1	P2	P3	PN	+C1-C1 Reverse	+C2-C2 Normal	+C3-C3 Reverse	Reverse connection of 1 side CT and 3 side CT					
	LEAD 0.866				150	90	30																
	1.000				180	120	60																
	LAG 0.866				210	150	90																
	LAG 0.707				225	165	105																
8	LEAD 0.707	0	120	240	135	255	15	W_1 =Negative value W_2 =Negative value W_3 =Negative value	$V_{1N}=V_{2N}=V_{3N}$	$I_1=I_2=I_3$	P1	P2	P3	PN	+C1-C1 Reverse	+C2-C2 Reverse	+C3-C3 Reverse	Reverse connection of 1 side CT, 2 side CT, and 3 side CT					
	LEAD 0.866				150	270	30																
	1.000				180	300	60																
	LAG 0.866				210	330	90																
	LAG 0.707				225	345	105																
9	LEAD 0.707	0	120	240	75	315	195	W_1 =Positive value W_2 =Negative value W_3 =Positive value $W_1=0$	$V_{1N}=V_{2N}=V_{3N}$	$I_1=I_2=I_3$	P1	P2	P3	PN	+C2-C2 Normal	+C1-C1 Normal	+C3-C3 Normal	Switch between 1 side CT and 2 side CT					
	LEAD 0.866				90	330	210																
	1.000				120	0	240																
	LAG 0.866				150	30	270																
	LAG 0.707				165	45	285																

9. Appendix

9.2. A List of Examples for Incorrect Wiring Display

9.2.1. 3-phase 4-wire System

No.	Power Factor (Input)	Phase Angle Display						At balanced load ($V_{1N}=V_{2N}=V_{3N}$, $I_1=I_2=I_3$)															Connection (Note 1)		
		Voltage Display			Current Display			Voltage			Current			Connection											
		$\angle V_{1N}$	$\angle V_{2N}$	$\angle V_{3N}$	$\angle I_1$	$\angle I_2$	$\angle I_3$	W_1	W_2	W_3	V_{1N}	V_{2N}	V_{3N}	I_1	I_2	I_3	1	2	3	N	1 side CT	2 side CT	3 side CT		
10	LEAD 0.707	0	120	240	315	195	75	W_1 =Positive value	W_2 =Positive value	W_3 =Positive value	$V_{1N}=V_{2N}=V_{3N}$	$I_1=I_2=I_3$	P1	P2	P3	PN	+C1-C1 Normal	+C3-C3 Normal	+C2-C2 Normal	Switch between 2 side CT and 3 side CT					
	LEAD 0.866				330	210	90	W_1 =Positive value	W_2 =0	W_3 =Positive value															
	1.000				0	240	120	W_1 =Negative value	W_2 =Negative value	W_3 =Negative value															
	LAG 0.866				30	270	150	W_1 =Positive value	W_2 =Negative value	W_3 =0															
	LAG 0.707				45	285	165	W_1 =Positive value	W_2 =Negative value	W_3 =Positive value															
								W_1 =Negative value	W_2 =Positive value	W_3 =Positive value															
11	LEAD 0.707	0	120	240	195	75	315	W_1 =Negative value	W_2 =Positive value	W_3 =Positive value	$V_{1N}=V_{2N}=V_{3N}$	$I_1=I_2=I_3$	P1	P2	P3	PN	+C3-C3 Normal	+C2-C2 Normal	+C1-C1 Normal	Switch between 1 side CT and 3 side CT					
	LEAD 0.866				210	90	330	W_1 =Negative value	W_2 =Positive value	W_3 =Positive value															
	1.000				240	120	0	W_1 =Negative value	W_2 =Positive value	W_3 =0															
	LAG 0.866				270	150	30	W_1 =Positive value	W_2 =Positive value	W_3 =Negative value															
	LAG 0.707				285	165	45	W_1 =Positive value	W_2 =Positive value	W_3 =Negative value															
								W_1 =Negative value	W_2 =Positive value	W_3 =Positive value															
12	LEAD 0.707	0	240	120	195	315	75	W_1 =Negative value	W_2 =Positive value	W_3 =Positive value	$V_{1N}=V_{2N}=V_{3N}$	$I_1=I_2=I_3$	P2	P1	P3	PN	+C1-C1 Normal	+C2-C2 Normal	+C3-C3 Normal	Reverse connection between terminals P1 and P2					
	LEAD 0.866				210	330	90	W_1 =Negative value	W_2 =Positive value	W_3 =0															
	1.000				240	0	120	W_1 =Positive value	W_2 =Negative value	W_3 =Positive value															
	LAG 0.866				270	30	150	W_1 =Positive value	W_2 =Positive value	W_3 =0															
	LAG 0.707				285	45	165	W_1 =Positive value	W_2 =Negative value	W_3 =Positive value															
								W_1 =Negative value	W_2 =Positive value	W_3 =Positive value															
13	LEAD 0.707	0	240	120	315	75	195	W_1 =Positive value	W_2 =Negative value	W_3 =Positive value	$V_{1N}=V_{2N}=V_{3N}$	$I_1=I_2=I_3$	P1	P3	P2	PN	+C1-C1 Normal	+C2-C2 Normal	+C3-C3 Normal	Reverse connection between terminals P2 and P3					
	LEAD 0.866				330	90	210	W_1 =Positive value	W_2 =Negative value	W_3 =Positive value															
	1.000				0	120	240	W_1 =Positive value	W_2 =Negative value	W_3 =0															
	LAG 0.866				30	150	270	W_1 =Positive value	W_2 =Negative value	W_3 =Positive value															
	LAG 0.707				45	165	285	W_1 =Positive value	W_2 =Positive value	W_3 =Negative value															
								W_1 =Negative value	W_2 =Positive value	W_3 =Positive value															
14	LEAD 0.707	0	240	120	75	195	315	W_1 =Positive value	W_2 =Positive value	W_3 =Negative value	$V_{1N}=V_{2N}=V_{3N}$	$I_1=I_2=I_3$	P3	P2	P1	PN	+C1-C1 Normal	+C2-C2 Normal	+C3-C3 Normal	Reverse connection between terminals P1 and P3					
	LEAD 0.866				90	210	330	W_1 =Positive value	W_2 =Negative value	W_3 =Negative value															
	1.000				120	240	0	W_1 =Negative value	W_2 =Positive value	W_3 =Positive value															
	LAG 0.866				150	270	30	W_1 =Negative value	W_2 =Positive value	W_3 =0															
	LAG 0.707				165	285	45	W_1 =Negative value	W_2 =Positive value	W_3 =Positive value															
								W_1 =Positive value	W_2 =Positive value	W_3 =Negative value															
15	LEAD 0.707	0	330	30	135	255	15	W_1 =Negative value	W_2 =Positive value	W_3 =Positive value	$V_{1N}<V_{2N}=V_{3N}$	$I_1=I_2=I_3$	PN	P2	P3	P1	+C1-C1 Normal	+C2-C2 Normal	+C3-C3 Normal	Reverse connection between terminals P1 and PN					
	LEAD 0.866				150	270	30	W_1 =Negative value	W_2 =Positive value	W_3 =Positive value															
	1.000				180	300	60	W_1 =Negative value	W_2 =Positive value	W_3 =Positive value															
	LAG 0.866				210	330	90	W_1 =Negative value	W_2 =Positive value	W_3 =Positive value															
	LAG 0.707				225	345	105	W_1 =Negative value	W_2 =Positive value	W_3 =Positive value															
								W_1 =Negative value	W_2 =Positive value	W_3 =Positive value															

9. Appendix

9.2. A List of Examples for Incorrect Wiring Display

9.2.1. 3-phase 4-wire System

No.	Power Factor (Input)	Phase Angle Display						At balanced load ($V_{1N}=V_{2N}=V_{3N}$, $I_1=I_2=I_3$)															Connection (Note 1)		
								Active Power Display			Voltage Display			Current Display			Voltage			Current					
		$\angle V_{1N}$	$\angle V_{2N}$	$\angle V_{3N}$	$\angle I_1$	$\angle I_2$	$\angle I_3$	W_1	W_2	W_3	V_{1N}	V_{2N}	V_{3N}	I_1	I_2	I_3	1	2	3	N	1 side CT	2 side CT	3 side CT	Connection	
16	LEAD 0.707	0	330	300	345	105	225	W_1 =Positive value W_2 =Negative value W_3 =Positive value	$V_{1N}=V_{2N}>V_{3N}$	$I_1=I_2=I_3$	P1	PN	P3	P2	+C1-C1 Normal	+C2-C2 Normal	+C3-C3 Normal	Reverse connection between terminals P2 and PN 							
	LEAD 0.866				0	120	240																		
	1.000				30	150	270																		
	LAG 0.866				60	180	300																		
	LAG 0.707				75	195	315																		
17	LEAD 0.707	0	60	30	285	45	165	W_1 =Positive value W_2 =Positive value W_3 =Negative value	$V_{1N}=V_{2N}>V_{3N}$	$I_1=I_2=I_3$	P1	P2	PN	P3	+C1-C1 Normal	+C2-C2 Normal	+C3-C3 Normal	Reverse connection between terminals P3 and PN 							
	LEAD 0.866				300	60	180																		
	1.000				330	90	210																		
	LAG 0.866				0	120	240																		
	LAG 0.707				15	135	255																		
18	LEAD 0.707	0	240	120	15	315	75	W_1 =Positive value W_2 =Positive value W_3 =Positive value $W_2=0$	$V_{1N}=V_{2N}=V_{3N}$	$I_1=I_2=I_3$	P2	P1	P3	PN	+C1-C1 Reverse	+C2-C2 Normal	+C3-C3 Normal	P1 and P2 terminals are reversed and the connection 1 side CT reversed 							
	LEAD 0.866				30	330	90																		
	1.000				60	0	120																		
	LAG 0.866				90	30	150																		
	LAG 0.707				105	45	165																		
19	LEAD 0.707	0	240	120	135	75	195	W_1 =Negative value W_2 =Negative value W_3 =Positive value $W_1=0$	$V_{1N}=V_{2N}=V_{3N}$	$I_1=I_2=I_3$	P1	P3	P2	PN	+C1-C1 Reverse	+C2-C2 Normal	+C3-C3 Normal	P2 and P3 terminals are reversed and the connection 1 side CT reversed 							
	LEAD 0.866				150	90	210																		
	1.000				180	120	240																		
	LAG 0.866				210	150	270																		
	LAG 0.707				225	165	285																		
20	LEAD 0.707	0	240	120	255	195	315	W_1 =Negative value W_2 =Positive value W_3 =Negative value $W_1=0$	$V_{1N}=V_{2N}=V_{3N}$	$I_1=I_2=I_3$	P3	P2	P1	PN	+C1-C1 Reverse	+C2-C2 Normal	+C3-C3 Normal	P1 and P3 terminals are reversed and the connection 1 side CT reversed 							
	LEAD 0.866				270	210	330																		
	1.000				300	240	0																		
	LAG 0.866				330	270	30																		
	LAG 0.707				345	285	45																		
21	LEAD 0.707	0	330	30	315	255	15	W_1 =Positive value W_2 =Positive value W_3 =Positive value	$V_{1N}<V_{2N}=V_{3N}$	$I_1=I_2=I_3$	PN	P2	P3	P1	+C1-C1 Reverse	+C2-C2 Normal	+C3-C3 Normal	P1 and PN terminals are reversed and the connection 1 side CT reversed 							
	LEAD 0.866				330	270	30																		
	1.000				0	300	60																		
	LAG 0.866				30	330	90																		
	LAG 0.707				45	345	105																		

9. Appendix

9.2. A List of Examples for Incorrect Wiring Display

9.2.1. 3-phase 4-wire System

No.	Power Factor (Input)	Phase Angle Display						At balanced load ($V_{1N}=V_{2N}=V_{3N}$, $I_1=I_2=I_3$)															Connection (Note 1)		
		$\angle V_{1N}$	$\angle V_{2N}$	$\angle V_{3N}$	$\angle I_1$	$\angle I_2$	$\angle I_3$	Active Power Display			Voltage Display			Current Display			Voltage			Current			Connection		
								W_1	W_2	W_3	V_{1N}	V_{2N}	V_{3N}	I_1	I_2	I_3	1	2	N	1 side CT	2 side CT	3 side CT			
22	LEAD 0.707	0	330	300	165	105	225	W_1 =Negative value W_2 =Negative value W_3 =Positive value	$V_{1N}=V_{2N}>V_{3N}$	$I_1=I_2=I_3$	P1	PN	P3	P2	+C1-C1 Reverse	+C2-C2 Normal	+C3-C3 Normal	<p>P2 and PN terminals are reversed and the connection 1 side CT reversed</p>							
	LEAD 0.866				180	120	240																		
	1.000				210	150	270																		
	LAG 0.866				240	180	300																		
	LAG 0.707				255	195	315																		
23	LEAD 0.707	0	60	30	105	45	165	W_1 =Negative value W_2 =Positive value W_3 =Negative value	$V_{1N}=V_{2N}>V_{3N}$	$I_1=I_2=I_3$	P1	P2	PN	P3	+C1-C1 Reverse	+C2-C2 Normal	+C3-C3 Normal	<p>P3 and PN terminals are reversed and the connection 1 side CT reversed</p>							
	LEAD 0.866				120	60	180																		
	1.000				150	90	210																		
	LAG 0.866				180	120	240																		
	LAG 0.707				195	135	255																		
24	LEAD 0.707	0	240	120	195	135	75	W_1 =Negative value W_2 =Negative value W_3 =Positive value W_1 =Positive value $W_2=0$	$V_{1N}=V_{2N}=V_{3N}$	$I_1=I_2=I_3$	P2	P1	P3	PN	+C1-C1 Normal	+C2-C2 Reverse	+C3-C3 Normal	<p>P1 and P2 terminals are reversed and the connection 2 side CT reversed</p>							
	LEAD 0.866				210	150	90																		
	1.000				240	180	120																		
	LAG 0.866				270	210	150																		
	LAG 0.707				285	225	165																		
25	LEAD 0.707	0	240	120	315	255	195	W_1 =Positive value W_2 =Positive value W_3 =Positive value	$V_{1N}=V_{2N}=V_{3N}$	$I_1=I_2=I_3$	P1	P3	P2	PN	+C1-C1 Normal	+C2-C2 Reverse	+C3-C3 Normal	<p>P1 and P2 terminals are reversed and the connection 1 side CT reversed</p>							
	LEAD 0.866				330	270	210																		
	1.000				0	300	240																		
	LAG 0.866				30	330	270																		
	LAG 0.707				45	345	285																		
26	LEAD 0.707	0	240	120	75	15	315	W_1 =Positive value W_2 =Negative value W_3 =Negative value $W_1=0$	$V_{1N}=V_{2N}=V_{3N}$	$I_1=I_2=I_3$	P3	P2	P1	PN	+C1-C1 Normal	+C2-C2 Reverse	+C3-C3 Normal	<p>P1 and P3 terminals are reversed and the connection 2 side CT reversed</p>							
	LEAD 0.866				90	30	330																		
	1.000				120	60	0																		
	LAG 0.866				150	90	30																		
	LAG 0.707				165	105	45																		
27	LEAD 0.707	0	330	30	135	75	15	W_1 =Negative value W_2 =Negative value W_3 =Positive value	$V_{1N}<V_{2N}=V_{3N}$	$I_1=I_2=I_3$	PN	P2	P3	P1	+C1-C1 Normal	+C2-C2 Reverse	+C3-C3 Normal	<p>P1 and PN terminals are reversed and the connection 2 side CT reversed</p>							
	LEAD 0.866				150	90	30																		
	1.000				180	120	60																		
	LAG 0.866				210	150	90																		
	LAG 0.707				225	165	105																		

9. Appendix

9.2. A List of Examples for Incorrect Wiring Display

9.2.1. 3-phase 4-wire System

No.	Power Factor (Input)	Phase Angle Display						At balanced load ($V_{1N}=V_{2N}=V_{3N}$, $I_1=I_2=I_3$)															Connection (Note 1)		
								Active Power Display			Voltage Display			Current Display			Voltage			Current					
		$\angle V_{1N}$	$\angle V_{2N}$	$\angle V_{3N}$	$\angle I_1$	$\angle I_2$	$\angle I_3$	W_1	W_2	W_3	V_{1N}	V_{2N}	V_{3N}	I_1	I_2	I_3	1	2	3	N	1 side CT	2 side CT	3 side CT		
28	LEAD 0.707	0	330	300	345	285	225	W_1 =Positive value W_2 =Positive value W_3 =Positive value	$V_{1N}=V_{2N}>V_{3N}$	$I_1=I_2=I_3$	P1	PN	P3	P2	+C1-C1 Normal	+C2-C2 Reverse	+C3-C3 Normal								
	LEAD 0.866				0	300	240																		
	1.000				30	330	270																		
	LAG 0.866				60	0	300																		
	LAG 0.707				75	15	315																		
29	LEAD 0.707	0	60	30	285	225	165	W_1 =Positive value W_2 =Negative value W_3 =Negative value	$V_{1N}=V_{2N}>V_{3N}$	$I_1=I_2=I_3$	P1	P2	PN	P3	+C1-C1 Normal	+C2-C2 Reverse	+C3-C3 Normal								
	LEAD 0.866				300	240	180																		
	1.000				330	270	210																		
	LAG 0.866				0	300	240																		
	LAG 0.707				15	315	255																		
30	LEAD 0.707	0	240	120	195	315	255	W_1 =Negative value W_2 =Positive value W_3 =Negative value W_1 =Negative value $W_2=0$	$V_{1N}=V_{2N}=V_{3N}$	$I_1=I_2=I_3$	P2	P1	P3	PN	+C1-C1 Normal	+C2-C2 Normal	+C3-C3 Reverse								
	LEAD 0.866				210	330	270																		
	1.000				240	0	300																		
	LAG 0.866				270	30	330																		
	LAG 0.707				285	45	345																		
31	LEAD 0.707	0	240	120	315	75	15	W_1 =Positive value W_2 =Negative value W_3 =Negative value W_1 =Negative value W_2 =Positive value $W_3=0$	$V_{1N}=V_{2N}=V_{3N}$	$I_1=I_2=I_3$	P1	P3	P2	PN	+C1-C1 Normal	+C2-C2 Normal	+C3-C3 Reverse								
	LEAD 0.866				330	90	30																		
	1.000				0	120	60																		
	LAG 0.866				30	150	90																		
	LAG 0.707				45	165	105																		
32	LEAD 0.707	0	240	120	75	195	135	W_1 =Positive value W_2 =Positive value W_3 =Positive value $W_1=0$	$V_{1N}=V_{2N}=V_{3N}$	$I_1=I_2=I_3$	P3	P2	P1	PN	+C1-C1 Normal	+C2-C2 Normal	+C3-C3 Reverse								
	LEAD 0.866				90	210	150																		
	1.000				120	240	180																		
	LAG 0.866				150	270	210																		
	LAG 0.707				165	285	225																		
33	LEAD 0.707	0	330	30	135	255	195	W_1 =Negative value W_2 =Positive value W_3 =Negative value	$V_{1N}<V_{2N}=V_{3N}$	$I_1=I_2=I_3$	PN	P2	P3	P1	+C1-C1 Normal	+C2-C2 Normal	+C3-C3 Reverse								
	LEAD 0.866				150	270	210																		
	1.000				180	300	240																		
	LAG 0.866				210	330	270																		
	LAG 0.707				225	345	285																		

9. Appendix

9.2. A List of Examples for Incorrect Wiring Display

9.2.1. 3-phase 4-wire System

No.	Power Factor (Input)	Phase Angle Display						At balanced load ($V_{1N}=V_{2N}=V_{3N}$, $I_1=I_2=I_3$)															Connection (Note 1)		
		$\angle V_{1N}$	$\angle V_{2N}$	$\angle V_{3N}$	$\angle I_1$	$\angle I_2$	$\angle I_3$	Active Power Display			Voltage Display			Current Display			Voltage			Current			Connection		
								W_1	W_2	W_3	V_{1N}	V_{2N}	V_{3N}	I_1	I_2	I_3	1	2	N	1 side CT	2 side CT	3 side CT			
34	LEAD 0.707	0	330	300	345	105	45	W_1 =Positive value W_2 =Negative value W_3 =Negative value	$V_{1N}=V_{2N}>V_{3N}$	$I_1=I_2=I_3$	P1	PN	P3	P2	+C1-C1 Normal	+C2-C2 Normal	+C3-C3 Reverse	<p>P2 and PN terminals are reversed and the connection 3 side CT reversed</p>							
	LEAD 0.866				0	120	60																		
	1.000				30	150	90																		
	LAG 0.866				60	180	120																		
	LAG 0.707				75	195	135																		
35	LEAD 0.707	0	60	30	285	45	345	W_1 =Positive value W_2 =Positive value W_3 =Positive value	$V_{1N}=V_{2N}>V_{3N}$	$I_1=I_2=I_3$	P1	P2	PN	P3	+C1-C1 Normal	+C2-C2 Normal	+C3-C3 Reverse	<p>P3 and PN terminals are reversed and the connection 3 side CT reversed</p>							
	LEAD 0.866				300	60	0																		
	1.000				330	90	30																		
	LAG 0.866				0	120	60																		
	LAG 0.707				15	135	75																		
36	LEAD 0.707	0	240	120	75	315	195	$W_1=W_2=W_3$	$V_{1N}=V_{2N}=V_{3N}$	$I_1=I_2=I_3$	P1	P3	P2	PN	+C2-C2 Normal	+C1-C1 Normal	+C3-C3 Normal	<p>P2 and P3 terminals are reversed and 1 side CT and 2 side CT are switched</p>							
	LEAD 0.866				90	330	210																		
	1.000				120	0	240																		
	LAG 0.866				150	30	270																		
	LAG 0.707				165	45	285																		
36	LEAD 0.707	0	240	120	75	315	195	$W_1=W_2=W_3$	$V_{1N}=V_{2N}=V_{3N}$	$I_1=I_2=I_3$	P3	P2	P1	PN	+C1-C1 Normal	+C3-C3 Normal	+C2-C2 Normal	<p>P1 and P3 terminals are reversed and 2 side CT and 3 side CT are switched</p>							
	LEAD 0.866				90	330	210																		
	1.000				120	0	240																		
	LAG 0.866				150	30	270																		
	LAG 0.707				165	45	285																		
36	LEAD 0.707	0	240	120	75	315	195	$W_1=W_2=W_3$	$V_{1N}=V_{2N}=V_{3N}$	$I_1=I_2=I_3$	P2	P1	P3	PN	+C3-C3 Normal	+C2-C2 Normal	+C1-C1 Normal	<p>P1 and P2 terminals are reversed and 1 side CT and 3 side CT are switched</p>							
	LEAD 0.866				90	330	210																		
	1.000				120	0	240																		
	LAG 0.866				150	30	270																		
	LAG 0.707				165	45	285																		

9. Appendix

9.2. A List of Examples for Incorrect Wiring Display

9.2.1. 3-phase 4-wire System

No.	Power Factor (Input)	Phase Angle Display						At balanced load ($V_{1N}=V_{2N}=V_{3N}$, $I_1=I_2=I_3$)															Connection (Note 1)		
								Active Power Display			Voltage Display			Current Display			Voltage			Current					
		$\angle V_{1N}$	$\angle V_{2N}$	$\angle V_{3N}$	$\angle I_1$	$\angle I_2$	$\angle I_3$	W_1	W_2	W_3	V_{1N}	V_{2N}	V_{3N}	I_1	I_2	I_3	1	2	3	N	1 side CT	2 side CT	3 side CT		
37	LEAD 0.707	0	240	120	195	75	315	$W_1=W_2=W_3$	$V_{1N}=V_{2N}=V_{3N}$	$I_1=I_2=I_3$	P3	P2	P1	PN	+C2-C2 Normal	+C1-C1 Normal	+C3-C3 Normal	<p>P1 and P3 terminals are reversed and 1 side CT and 2 side CT are switched</p>							
	LEAD 0.866				210	90	330																		
	1.000				240	120	0																		
	LAG 0.866				270	150	30																		
	LAG 0.707				285	165	45																		
38	LEAD 0.707	0	330	30	255	135	15	W_1 =Negative value W_2 =Negative value W_3 =Positive value $W_1=0$	$V_{1N}<V_{2N}=V_{3N}$	$I_1=I_2=I_3$	PN	P2	P3	P1	+C2-C2 Normal	+C1-C1 Normal	+C3-C3 Normal	<p>P1 and PN terminals are reversed and 1 side CT and 2 side CT are switched</p>							
	LEAD 0.866				270	150	30												W_2 =Negative value W_3 =Positive value						
	1.000				300	180	60																		
	LAG 0.866				330	210	90																		
	LAG 0.707				345	225	105																		
39	LEAD 0.707	0	330	300	105	345	225	W_1 =Negative value W_2 =Positive value W_3 =Positive value	$V_{1N}=V_{3N}>V_{2N}$	$I_1=I_2=I_3$	P1	PN	P3	P2	+C2-C2 Normal	+C1-C1 Normal	+C3-C3 Normal	<p>P2 and PN terminals are reversed and 1 side CT and 2 side CT are switched</p>							
	LEAD 0.866				120	0	240																		
	1.000				150	30	270																		
	LAG 0.866				180	60	300																		
	LAG 0.707				195	75	315																		
40	LEAD 0.707	0	60	30	45	285	165	W_1 =Positive value W_2 =Negative value W_3 =Negative value	$V_{1N}=V_{2N}>V_{3N}$	$I_1=I_2=I_3$	P1	P2	PN	P3	+C2-C2 Normal	+C1-C1 Normal	+C3-C3 Normal	<p>P3 and PN terminals are reversed and 1 side CT and 2 side CT are switched</p>							
	LEAD 0.866				60	300	180																		
	1.000				90	330	210																		
	LAG 0.866				120	0	240																		
	LAG 0.707				135	15	255																		

9. Appendix

9.2. A List of Examples for Incorrect Wiring Display

9.2.1. 3-phase 4-wire System

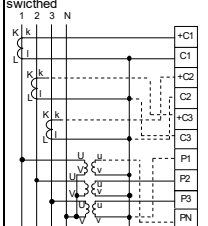
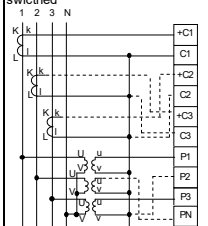
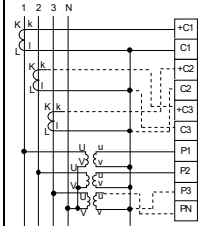
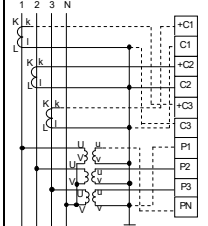
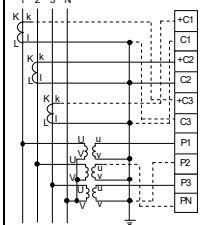
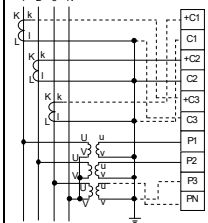
No.	Power Factor (Input)	Phase Angle Display						At balanced load ($V_{1N}=V_{2N}=V_{3N}$, $I_1=I_2=I_3$)									Connection (Note 1)						
		$\angle V_{1N}$	$\angle V_{2N}$	$\angle V_{3N}$	$\angle I_1$	$\angle I_2$	$\angle I_3$	Active Power Display			Voltage Display			Current Display			Voltage			Current			Connection
								W_1	W_2	W_3	V_{1N}	V_{2N}	V_{3N}	I_1	I_2	I_3	1	2	3	N	1 side CT	2 side CT	
41	LEAD 0.707	0	330	30	135	15	255	W_1 =Negative value W_2 =Positive value W_3 =Negative value	$V_{1N}<V_{2N}=V_{3N}$	$I_1=I_2=I_3$	PN	P2	P3	P1	+C1-C1 Normal	+C3-C3 Normal	+C2-C2 Normal	<p>P1 and PN terminals are reversed and 2 side CT and 3 side CT are switched</p> 					
	LEAD 0.866				150	30	270																
	1.000				180	60	300												W_1 =Negative value $W_2=0$ $W_3=0$				
	LAG 0.866				210	90	330												W_1 =Negative value W_2 =Negative value W_3 =Positive value				
	LAG 0.707				225	105	345																
42	LEAD 0.707	0	330	300	345	225	105	W_1 =Positive value W_2 =Negative value W_3 =Negative value	$V_{1N}=V_{2N}>V_{3N}$	$I_1=I_2=I_3$	P1	PN	P3	P2	+C1-C1 Normal	+C3-C3 Normal	+C2-C2 Normal	<p>P2 and PN terminals are reversed and 2 side CT and 3 side CT are switched</p> 					
	LEAD 0.866				0	240	120												W_1 =Positive value $W_2=0$ W_3 =Negative value				
	1.000				30	270	150												W_1 =Positive value W_2 =Positive value W_3 =Negative value				
	LAG 0.866				60	300	180																
	LAG 0.707				75	315	195																
43	LEAD 0.707	0	60	30	285	165	45	W_1 =Positive value W_2 =Negative value W_3 =Positive value	$V_{1N}=V_{2N}>V_{3N}$	$I_1=I_2=I_3$	P1	P2	PN	P3	+C1-C1 Normal	+C3-C3 Normal	+C2-C2 Normal	<p>P3 and PN terminals are reversed and 2 side CT and 3 side CT are switched</p> 					
	LEAD 0.866				300	180	60												W_1 =Positive value W_2 =Negative value W_3 =Positive value				
	1.000				330	210	90												W_1 =Positive value W_2 =Negative value $W_3=0$				
	LAG 0.866				0	240	120												W_1 =Positive value W_2 =Negative value $W_3=0$				
	LAG 0.707				15	255	135												W_1 =Positive value W_2 =Negative value W_3 =Negative value				
44	LEAD 0.707	0	330	30	15	255	135	W_1 =Positive value W_2 =Positive value W_3 =Negative value	$V_{1N}<V_{2N}=V_{3N}$	$I_1=I_2=I_3$	PN	P2	P3	P1	+C3-C3 Normal	+C2-C2 Normal	+C1-C1 Normal	<p>P1 and PN terminals are reversed and 1 side CT and 3 side CT are switched</p> 					
	LEAD 0.866				30	270	150												W_1 =Positive value W_2 =Positive value W_3 =Negative value				
	1.000				60	300	180												$W_1=0$ W_2 =Positive value W_3 =Negative value				
	LAG 0.866				90	330	210												W_1 =Negative value W_2 =Positive value W_3 =Negative value				
	LAG 0.707				105	345	225												W_1 =Positive value W_2 =Positive value W_3 =Negative value				
45	LEAD 0.707	0	330	300	225	105	345	W_1 =Negative value W_2 =Negative value W_3 =Positive value	$V_{1N}=V_{3N}>V_{2N}$	$I_1=I_2=I_3$	P1	PN	P3	P2	+C3-C3 Normal	+C2-C2 Normal	+C1-C1 Normal	<p>P2 and PN terminals are reversed and 1 side CT and 3 side CT are switched</p> 					
	LEAD 0.866				240	120	0												$W_1=0$ W_2 =Negative value W_3 =Positive value				
	1.000				270	150	30												W_1 =Negative value W_2 =Negative value $W_3=0$				
	LAG 0.866				300	180	60												W_1 =Positive value W_2 =Negative value W_3 =Negative value				
	LAG 0.707				315	195	75												W_1 =Positive value W_2 =Negative value W_3 =Negative value				
46	LEAD 0.707	0	60	30	165	45	285	W_1 =Negative value W_2 =Positive value W_3 =Negative value	$V_{1N}=V_{2N}>V_{3N}$	$I_1=I_2=I_3$	P1	P2	PN	P3	+C3-C3 Normal	+C2-C2 Normal	+C1-C1 Normal	<p>P3 and PN terminals are reversed and 1 side CT and 3 side CT are switched</p> 					
	LEAD 0.866				180	60	300												W_1 =Positive value W_2 =Positive value $W_3=0$				
	1.000				210	90	330												W_1 =Negative value W_2 =Positive value W_3 =Positive value				
	LAG 0.866				240	120	0												W_1 =Negative value W_2 =Positive value W_3 =Positive value				
	LAG 0.707				255	135	15												W_1 =Negative value W_2 =Positive value W_3 =Positive value				

Note1: The above examples for incorrect wiring are typical. Extreme cases are excluded such as burnout or destruction of the instrument, VT, or CT caused by voltage application to a current circuit or current application to a voltage circuit.

Note : The active power polarity may be displayed in reverse depending on the load status (low power factor, unbalanced load) even if the connection is correct.

9. Appendix

9.2. A List of Examples for Incorrect Wiring Display

9.2.2. 3-phase 3-wire System

*The shaded parts indicate influential parts caused by incorrect wiring.
The dashed lines show incorrect wiring parts.

No.	Power Factor (Input)	At balanced load ($V_{12}=V_{23}, I_1=I_3$)											Connection (Note 7)					
		Phase Angle Display				Active Power Display		Voltage Display			Current Display			Voltage		Current		Connection
		$\angle V_{12}$	$\angle V_{32}$	$\angle I_1$	$\angle I_3$	W_1	W_3	V_{12}	V_{23}	V_{31}	I_1	I_2	I_3	1	2	3	1 side CT	
1	LEAD 0.707	0	300	345	225	$W_1 > W_3$	$V_{12}=V_{23}=V_{31}$			$I_1=I_2=I_3$	P1	P2	P3	+C1-C1 Normal	+C3-C3 Normal	Normal		
	LEAD 0.866			0	240													$W_1 = W_3$
	1.000			30	270	$W_1 < W_3$												
	LAG 0.866			60	300													
	LAG 0.707			75	315													
2	LEAD 0.707	0	300	165	225	$W_1 = \text{Negative value}$ $W_3 = \text{Positive value}$	$V_{12}=V_{23}=V_{31}$		$I_1=I_3 < I_2$	P1	P2	P3	+C1-C1 Reverse	+C3-C3 Normal	Reverse connection of 1 side CT			
	LEAD 0.866			180	240													
	1.000			210	270													
	LAG 0.866			240	300													
	LAG 0.707			255	315													
3	LEAD 0.707	0	300	345	45	$W_1 = \text{Positive value}$ $W_3 = \text{Negative value}$	$V_{12}=V_{23}=V_{31}$		$I_1=I_3 < I_2$	P1	P2	P3	+C1-C1 Normal	+C3-C3 Reverse	Reverse connection of 3 side CT			
	LEAD 0.866			0	60													
	1.000			30	90													
	LAG 0.866			60	120													
	LAG 0.707			75	135													
4	LEAD 0.707	0	300	165	45	$W_1 = \text{Negative value}$ $W_3 = \text{Negative value}$	$V_{12}=V_{23}=V_{31}$		$I_1=I_2=I_3$	P1	P2	P3	+C1-C1 Reverse	+C3-C3 Reverse	Reverse connection of 1 side VT and 3 side VT			
	LEAD 0.866			180	60													
	1.000			210	90													
	LAG 0.866			240	120													
	LAG 0.707			255	135													

9. Appendix

9.2. A List of Examples for Incorrect Wiring Display



9.2.2. 3-phase 3-wire System

No.	Power Factor (Input)	At balanced load ($V_{12}=V_{23}, I_1=I_3$)										Connection (Note 7)						
		Phase Angle Display				Active Power Display		Voltage Display			Current Display			Voltage		Current		Connection
		$\angle V_{12}$	$\angle V_{32}$	$\angle I_1$	$\angle I_3$	W_1	W_3	V_{12}	V_{23}	V_{31}	I_1	I_2	I_3	1	2	3	1 side CT	
5	LEAD 0.707	0	300	225	345	W_1 =Negative value W_3 =Positive value	$V_{12}=V_{23}=V_{31}$		$I_1=I_2=I_3$	P1	P2	P3	+C3-C3 Normal	+C1-C1 Normal	Switch between 1 side CT and 3 side CT			
	LEAD 0.866			240	0													
	1.000			270	30	$W_1=W_3=0$												
	LAG 0.866			300	60	W_1 =Positive value W_3 =Negative value												
	LAG 0.707			315	75													
6	LEAD 0.707	0	60	165	45	W_1 =Negative value W_3 =Positive value	$V_{12}=V_{23}=V_{31}$		$I_1=I_2=I_3$	P2	P1	P3	+C1-C1 Normal	+C3-C3 Normal	Reverse connection between terminals P1 and P2			
	LEAD 0.866			180	60													
	1.000			210	90													
	LAG 0.866			240	120													
	LAG 0.707			255	135													
7	LEAD 0.707	0	60	285	165	W_1 =Positive value W_3 =Negative value	$V_{12}=V_{23}=V_{31}$		$I_1=I_2=I_3$	P1	P3	P2	+C1-C1 Normal	+C3-C3 Normal	Reverse connection between terminals P2 and P3			
	LEAD 0.866			300	180													
	1.000			330	210													
	LAG 0.866			0	240													
	LAG 0.707			15	255													
8	LEAD 0.707	0	60	45	285	W_1 =Positive value W_3 =Negative value	$V_{12}=V_{23}=V_{31}$		$I_1=I_2=I_3$	P3	P2	P1	+C1-C1 Normal	+C3-C3 Normal	Reverse connection between terminals P1 and P3			
	LEAD 0.866			60	300													
	1.000			90	330	$W_1=W_3=0$												
	LAG 0.866			120	0	W_1 =Negative value W_3 =Positive value												
	LAG 0.707			135	15													

9. Appendix

9.2. A List of Examples for Incorrect Wiring Display

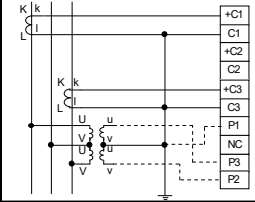
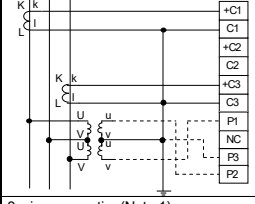
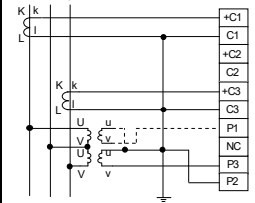
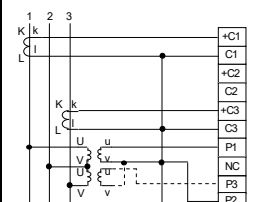
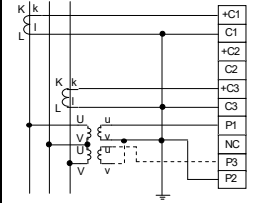
9.2.2. 3-phase 3-wire System

No.	Power Factor (Input)	At balanced load ($V_{12}=V_{23}$, $I_1=I_3$)										Connection (Note 7)						
		Phase Angle Display				Active Power Display		Voltage Display			Current Display			Voltage		Current		Connection
		$\angle V_{12}$	$\angle V_{32}$	$\angle I_1$	$\angle I_3$	W_1	W_3	V_{12}	V_{23}	V_{31}	I_1	I_2	I_3	1	2	3	1 side CT	
9	LEAD 0.707			225	105	W_1 =Negative value W_3 =Negative value	$V_{12}=V_{23}=V_{31}$		$I_1=I_2=I_3$	1	2	3	P3	P1	P2	+C1-C1 Normal	+C3-C3 Normal	P3, P1, and P2 terminals of VT are connected to P1, P2, and P3 terminals of the instrument in that order 
	LEAD 0.866			240	120													
	1.000	0	300	270	150	$W_1=0$ W_3 =Negative value												Refer to the right figure
	LAG 0.866			300	180	W_1 =Positive value W_3 =Negative value												
	LAG 0.707			315	195	W_1 =Positive value W_3 =Negative value												
10	LEAD 0.707			105	345	W_1 =Negative value W_3 =Positive value	$V_{12}=V_{23}=V_{31}$		$I_1=I_2=I_3$	1	2	3	P2	P3	P1	+C1-C1 Normal	+C3-C3 Normal	P2, P3, and P1 terminals of VT are connected to P1, P2, and P3 terminals of the instrument in that order 
	LEAD 0.866			120	0													
	1.000	0	300	150	30	W_1 =Negative value $W_3=0$												Refer to the right figure
	LAG 0.866			180	60	W_1 =Negative value W_3 =Negative value												
	LAG 0.707			195	75	W_1 =Negative value W_3 =Negative value												
11	LEAD 0.707			165	45	W_1 =Negative value W_3 =Positive value	$V_{12}=V_{23} < V_{31}$		$I_1=I_2=I_3$	1	2	3	Reverse connection of 1 side VT *Refer to the right diagram.		+C1-C1 Normal	+C3-C3 Normal	Reverse connection of 1 side VT 	
	LEAD 0.866			180	60													3 wire connection(Note 1) 
	1.000	0	120	210	90												Refer to the right diagram.	
	LAG 0.866			240	120													
	LAG 0.707			255	135													
12	LEAD 0.707			345	225	W_1 =Positive value W_3 =Negative value	$V_{12}=V_{23} < V_{31}$		$I_1=I_2=I_3$	1	2	3	Reverse connection of 3 side VT *Refer to the right diagram.		+C1-C1 Normal	+C3-C3 Normal	Reverse connection of 3 side VT 	
	LEAD 0.866			0	240													3 wire connection(Note 1) 
	1.000	0	120	30	270												Refer to the right diagram.	
	LAG 0.866			60	300													
	LAG 0.707			75	315													

9. Appendix

9.2. A List of Examples for Incorrect Wiring Display

9.2.2. 3-phase 3-wire System

No.	Power Factor (Input)	At balanced load ($V_{12}=V_{23}, I_1=I_3$)										Connection (Note 7)						
		Phase Angle Display				Active Power Display		Voltage Display			Current Display			Voltage		Current		Connection
		$\angle V_{12}$	$\angle V_{32}$	$\angle I_1$	$\angle I_3$	W_1	W_3	V_{12}	V_{23}	V_{31}	I_1	I_2	I_3	1	2	3	1 side CT	
13	LEAD 0.707	0	300	165	45	$W_1 = \text{Negative value}$ $W_3 = \text{Negative value}$	$V_{12} = V_{23} = V_{31}$	$I_1 = I_2 = I_3$	Each of 1 side VT terminal and 3 side VT terminal is reversed. *Refer to the right diagram.	+C1-C1 Normal	+C3-C3 Normal	Reverse connection of 1 side VT and 3 side VT						
	LEAD 0.866			180	60													
	1.000			210	90													
	LAG 0.866			240	120													
	LAG 0.707			255	135													
14	LEAD 0.707	0	60	285	45	$W_1 < W_3$	$V_{12} = V_{23} = V_{31}$	$I_1 = I_2 = I_3$	P3	P2	P1	+C3-C3 Normal	+C1-C1 Normal	Reversed phase sequence				
	LEAD 0.866			300	60													
	1.000			330	90	$W_1 = W_3$												
	LAG 0.866			0	120	$W_1 > W_3$												
	LAG 0.707			15	135													
15	LEAD 0.707	0	60	345	45	$W_1 = W_3$	$V_{12} = V_{23} = V_{31}$	$I_1 = I_3 < I_2$	P2	P1	P3	+C1-C1 Reverse	+C3-C3 Normal	P1 and P2 terminals are reversed and 1 side CT reversed				
	LEAD 0.866			0	60													
	1.000			30	90													
	LAG 0.866			60	120													
	LAG 0.707			75	135													
16	LEAD 0.707	0	60	165	225	$W_1 = \text{Negative value}$ $W_3 = \text{Negative value}$	$V_{12} = V_{23} = V_{31}$	$I_1 = I_3 < I_2$	P2	P1	P3	+C1-C1 Normal	+C3-C3 Reverse	P1 and P2 terminals are reversed and 3 side CT reversed				
	LEAD 0.866			180	240													
	1.000			210	270													
	LAG 0.866			240	300													
	LAG 0.707			255	315													
17	LEAD 0.707	0	60	345	225	$W_1 = \text{Positive value}$ $W_3 = \text{Negative value}$	$V_{12} = V_{23} = V_{31}$	$I_1 = I_2 = I_3$	P2	P1	P3	+C1-C1 Reverse	+C3-C3 Reverse	P1 and P2 terminals are reversed and 1 side CT and 3 side CT are reversed				
	LEAD 0.866			0	240													
	1.000			30	270													
	LAG 0.866			60	300													
	LAG 0.707			75	315													
18	LEAD 0.707	0	60	105	165	$W_1 = W_3 = \text{Negative value}$	$V_{12} = V_{23} = V_{31}$	$I_1 = I_3 < I_2$	P1	P3	P2	+C1-C1 Reverse	+C3-C3 Normal	P2 and P3 terminals are reversed and 1 side CT reversed				
	LEAD 0.866			120	180													
	1.000			150	210													
	LAG 0.866			180	240													
	LAG 0.707			195	255													

9. Appendix

9.2. A List of Examples for Incorrect Wiring Display

9.2.2. 3-phase 3-wire System

No.	Power Factor (Input)	At balanced load ($V_{12}=V_{23}$, $I_1=I_3$)										Connection (Note 7)						
		Phase Angle Display				Active Power Display		Voltage Display			Current Display			Voltage		Current		Connection
		$\angle V_{12}$	$\angle V_{32}$	$\angle I_1$	$\angle I_3$	W_1	W_3	V_{12}	V_{23}	V_{31}	I_1	I_2	I_3	1	2	3	1 side CT	
19	LEAD 0.707	0	60	285	345	$W_1 > W_3$	$V_{12}=V_{23}=V_{31}$	$I_1=I_3 < I_2$	P1	P3	P2	+C1-C1 Normal	+C3-C3 Reverse	P2 and P3 terminals are reversed and 3 side CT reversed 				
	LEAD 0.866			300	0													
	1.000			330	30	$W_1 = W_3$												
	LAG 0.866			0	60	$W_1 < W_3$												
	LAG 0.707			15	75													
20	LEAD 0.707	0	60	225	285	$W_1 = W_3 = \text{Negative value}$	$V_{12}=V_{23}=V_{31}$	$I_1=I_3 < I_2$	P3	P2	P1	+C1-C1 Reverse	+C3-C3 Normal	P1 and P3 terminals are reversed and 1 side CT reversed 				
	LEAD 0.866			240	300													
	1.000			270	330	$W_1 = W_3 = 0$												
	LAG 0.866			300	0	$W_1 = W_3 = \text{Positive value}$												
	LAG 0.707			315	15													
21	LEAD 0.707	0	60	45	105	$W_1 = W_3 = \text{Positive value}$	$V_{12}=V_{23}=V_{31}$	$I_1=I_3 < I_2$	P3	P2	P1	+C1-C1 Normal	+C3-C3 Reverse	P1 and P3 terminals are reversed and 3 side CT reversed 				
	LEAD 0.866			60	120													
	1.000			90	150	$W_1 = W_3 = 0$												
	LAG 0.866			120	180	$W_1 = W_3 = \text{Negative value}$												
	LAG 0.707			135	195													
22	LEAD 0.707	0	120	345	45	$W_1 > W_3$	$V_{12}=V_{23} < V_{31}$	$I_1=I_3 < I_2$	Reverse connection of 1 side VT *Refer to the right diagram.	+C1-C1 Reverse	+C3-C3 Normal	1 side VT reversed and 1 side CT reversed 						
	LEAD 0.866			0	60													
	1.000			30	90	$W_1 = W_3$												
	LAG 0.866			60	120	$W_1 < W_3$												
	LAG 0.707			75	135													
23	LEAD 0.707	0	120	165	225	$W_1 = \text{Negative value}$ $W_3 = \text{Negative value}$	$V_{12}=V_{23} < V_{31}$	$I_1=I_3 < I_2$	Reverse connection of 1 side VT *Refer to the right diagram.	+C1-C1 Normal	+C3-C3 Reverse	1 side VT reversed and 3 side CT reversed 						
	LEAD 0.866			180	240													
	1.000			210	270													
	LAG 0.866			240	300												Reverse connection of 3 side VT *Refer to the right diagram.	
	LAG 0.707			255	315													3 side VT reversed and 1 side CT reversed

9. Appendix

9.2. A List of Examples for Incorrect Wiring Display

9.2.2. 3-phase 3-wire System

No.	Power Factor (Input)	At balanced load ($V_{12}=V_{23}$, $I_1=I_3$)										Connection (Note 7)						
		Phase Angle Display				Active Power Display		Voltage Display			Current Display			Voltage		Current		Connection
		$\angle V_{12}$	$\angle V_{32}$	$\angle I_1$	$\angle I_3$	W_1	W_3	V_{12}	V_{23}	V_{31}	I_1	I_2	I_3	1	2	3	1 side CT	
24	LEAD 0.707	0	120	285	165	$W_1 < W_3$	$V_{12}=V_{23} < V_{31}$	$I_1=I_2=I_3$	Reverse connection of 1 side VT *Refer to the right diagram.	Refer to the right figure	1 side VT reversed and 3 wire connection(Note1)							
	LEAD 0.866			300	180	$W_1 = W_3$												
	1.000			330	210	$W_1 > W_3 = 0$												
	LAG 0.866			0	240	$W_1 = \text{Positive value}$ $W_3 = \text{Negative value}$												
	LAG 0.707			15	255													
25	LEAD 0.707	0	120	105	345	$W_1 = \text{Negative value}$ $W_3 = \text{Negative value}$	$V_{12}=V_{23} < V_{31}$	$I_1=I_2=I_3$	Reverse connection of 3 side VT *Refer to the right diagram.	Refer to the right figure	3 side VT reversed and 3 wire connection(Note1)							
	LEAD 0.866			120	0													
	1.000			150	30	$W_1 = \text{Negative value}$ $W_3 = 0$												
	LAG 0.866			180	60	$W_1 = \text{Negative value}$ $W_3 = \text{Positive value}$												
	LAG 0.707			195	75													
26	LEAD 0.707	0	300	105	225	$W_1 = \text{Negative value}$ $W_3 = \text{Positive value}$	$V_{12}=V_{23}=V_{31}$	$I_1=I_2=I_3$	P1 P2 P3	Refer to the right figure	3 wire connection(Note3)							
	LEAD 0.866			120	240													
	1.000			150	270													
	LAG 0.866			180	300													
	LAG 0.707			195	315													
27	LEAD 0.707	0	300	345	105	$W_1 = \text{Positive value}$ $W_3 = \text{Negative value}$	$V_{12}=V_{23}=V_{31}$	$I_1=I_2=I_3$	P1 P2 P3	Refer to the right figure	3 wire connection(Note4)							
	LEAD 0.866			0	120													
	1.000			30	150													
	LAG 0.866			60	180													
	LAG 0.707			75	195													
28	LEAD 0.707	0	300	15	225	$W_1 > W_3$	$V_{12}=V_{23}=V_{31}$	$I_2=I_3 < I_1$	P1 P2 P3	Refer to the right figure	3 wire connection(Note5)							
	LEAD 0.866			30	240													
	1.000			60	270													
	LAG 0.866			90	300													
	LAG 0.707			105	315													
29	LEAD 0.707	0	300	345	195	$W_1 = \text{Positive value}$ $W_3 = \text{Negative value}$	$V_{12}=V_{23}=V_{31}$	$I_1=I_2 < I_3$	P1 P2 P3	Refer to the right figure	3 wire connection(Note6)							
	LEAD 0.866			0	210													
	1.000			30	240													
	LAG 0.866			60	270													
	LAG 0.707			75	285													

9. Appendix

9.2. A List of Examples for Incorrect Wiring Display

9.2.2. 3-phase 3-wire System

No.	Power Factor (Input)	At balanced load ($V_{12}=V_{23}, I_1=I_2$)										Connection (Note 7)					
		Phase Angle Display			Active Power Display		Voltage Display			Current Display			Voltage		Current		Connection
		$\angle V_{12}$	$\angle V_{32}$	$\angle I_1$	$\angle I_3$	W_1	W_3	V_{12}	V_{23}	V_{31}	I_1	I_2	I_3	1	2	3	
30	LEAD 0.707	0	300	45	105	W_1 =Positive value W_3 =Negative value	$V_{12}=V_{23}=V_{31}$	$I_1=I_2 < I_3$	P3	P1	P2	+C1-C1 Reverse	+C3-C3 Normal				
	LEAD 0.866			60	120												
	1.000			90	150										$W_1=0$ W_3 =Negative value		
	LAG 0.866			120	180										W_1 =Negative value W_3 =Negative value		
	LAG 0.707			135	195										W_1 =Negative value W_3 =Negative value		
31	LEAD 0.707	0	300	225	285	W_1 =Negative value W_3 =Positive value	$V_{12}=V_{23}=V_{31}$	$I_1=I_2 < I_3$	P3	P1	P2	+C1-C1 Normal	+C3-C3 Reverse				
	LEAD 0.866			240	300												
	1.000			270	330										$W_1=0$ W_3 =Positive value		
	LAG 0.866			300	0										$W_1=W_3$		
	LAG 0.707			315	15										$W_1 > W_3$		
32	LEAD 0.707	0	300	285	345	$W_1 < W_3$	$V_{12}=V_{23}=V_{31}$	$I_1=I_2 < I_3$	P2	P3	P1	+C1-C1 Reverse	+C3-C3 Normal				
	LEAD 0.866			300	0										$W_1=W_3$		
	1.000			330	30										W_1 =Positive value $W_3=0$		
	LAG 0.866			0	60										W_1 =Positive value W_3 =Negative value		
	LAG 0.707			15	75										W_1 =Positive value W_3 =Negative value		
33	LEAD 0.707	0	300	105	165	W_1 =Negative value W_3 =Negative value	$V_{12}=V_{23}=V_{31}$	$I_1=I_2 < I_3$	P2	P3	P1	+C1-C1 Normal	+C3-C3 Reverse				
	LEAD 0.866			120	180												
	1.000			150	210										W_1 =Negative value $W_3=0$		
	LAG 0.866			180	240										W_1 =Negative value W_3 =Positive value		
	LAG 0.707			195	255										W_1 =Negative value W_3 =Positive value		

Note1: When 1 side CT and 3 side CT switch to each other, and in addition, the terminals 'C3' and '+C3' of CT are connected to the terminals '+C1' and 'C1' of the instrument in that order.

Note2: When 1 side CT and 3 side CT switch to each other, and in addition, the terminals 'C1' and '+C1' of CT are connected to the terminals '+C3' and 'C3' of the instrument in that order.

Note3: When the terminals 'C1' and '+C1' of CT are connected to the terminals '+C1' and 'C1' of the instrument in that order.

Note4: When the terminals 'C3' and '+C3' of CT are connected to the terminals '+C3' and 'C3' of the instrument in that order.

Note5: When '+C1' and 'C3' of CT are connected and it is connected to the '+C1' terminal of the instrument.

Note6: When 'C1' and '+C3' of CT are connected and it is connected to the '+C3' terminal of the instrument.

Note7: The above examples for incorrect wiring are typical. Extreme cases are excluded such as burnout or destruction of the instrument, VT, or CT caused by voltage application to a current circuit or current application to a voltage circuit.

Note : The active power polarity may be displayed in reverse depending on the load status (low power factor, unbalanced load) even if the connection is correct.

Note : The above table shows incorrect wiring display examples of 3-phase 3-wire system (2CT). Those of 3-phase 3-wire system (3CT) are also the same. However, it is not possible to detect the incorrect wiring of the CT secondary side.

9. Appendix

9.2. A List of Examples for Incorrect Wiring Display

9.2.3. 1-phase 3-wire System

*The shaded parts indicate influential parts caused by incorrect wiring.
The dashed lines show incorrect wiring parts.

No.	Power Factor (Input)	At balanced load ($V_{1N}=V_{3N}$ (or V_{2N}), $I_1=I_3$ (or I_2))										Connection (Note 1)						
		Phase Angle Display				Active Power Display		Voltage Display			Current Display			Voltage		Current		Connection
		$\angle V_{1N}$	$\angle V_{3N}$	$\angle I_1$	$\angle I_3$	W_1	W_3	V_{1N}	V_{3N}	V_{13}	I_1	I_3	I_N	1	N	3	1 side CT	
1	LEAD 0.707			315	135	$W_1=W_3$	$V_{1N}=V_{3N}<V_{13}$	$I_1=I_3$	$I_N=0$	P1	PN	P3	+C1-C1 Normal	+C3-C3 Normal	Normal			
	LEAD 0.866			330	150										Reversed phase sequence			
	1.000	0	180	0	180										Reverse connection of 1 side CT			
	LAG 0.866			30	210										Reverse connection of 3 side CT			
	LAG 0.707			45	225										Reverse connection of 1 side CT and 3 side CT			
2	LEAD 0.707			135	135	W_1 =Negative value W_3 =Positive value	$V_{1N}=V_{3N}<V_{13}$	$I_1=I_3<I_N$	P1	PN	P3	+C1-C1 Reverse	+C3-C3 Normal	Switch between 1 side CT and 3 side CT				
	LEAD 0.866			150	150									Reverse connection between terminals P1 and PN				
	1.000	0	180	180	180													
	LAG 0.866			210	210													
	LAG 0.707			225	225													
3	LEAD 0.707			315	315	W_1 =Positive value W_3 =Negative value	$V_{1N}=V_{3N}<V_{13}$	$I_1=I_3<I_N$	P1	PN	P3	+C1-C1 Normal	+C3-C3 Reverse					
	LEAD 0.866			330	330													
	1.000	0	180	0	0													
	LAG 0.866			30	30													
	LAG 0.707			45	45													
4	LEAD 0.707			135	315	W_1 =Negative value W_3 =Negative value	$V_{1N}=V_{3N}<V_{13}$	$I_1=I_3$	$I_N=0$	P1	PN	P3	+C1-C1 Reverse	+C3-C3 Reverse				
	LEAD 0.866			150	330													
	1.000	0	180	180	0													
	LAG 0.866			210	30													
	LAG 0.707			225	45													
5	LEAD 0.707			135	315	W_1 =Negative value W_3 =Negative value	$V_{1N}=V_{3N}<V_{13}$	$I_1=I_3$	$I_N=0$	P1	PN	P3	+C3-C3 Normal	+C1-C1 Normal				
	LEAD 0.866			150	330													
	1.000	0	180	180	0													
	LAG 0.866			210	30													
	LAG 0.707			225	45													
6	LEAD 0.707			135	315	W_1 =Negative value W_3 =Positive value	$V_{1N}=V_{13}<V_{3N}$	$I_1=I_3$	$I_N=0$	PN	P1	P3	+C1-C1 Normal	+C3-C3 Normal				
	LEAD 0.866			150	330													
	1.000	0	0	180	0													
	LAG 0.866			210	30													
	LAG 0.707			225	45													

9. Appendix

9.2. A List of Examples for Incorrect Wiring Display

9.2.3. 1-phase 3-wire System

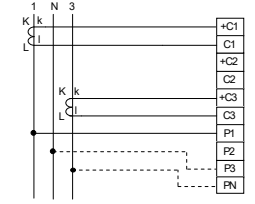
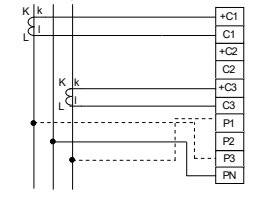
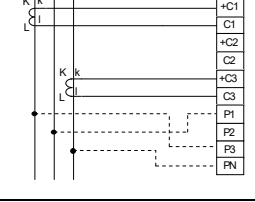
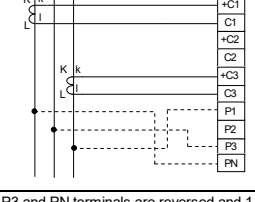
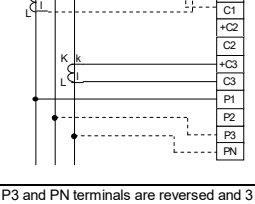
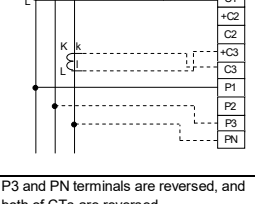
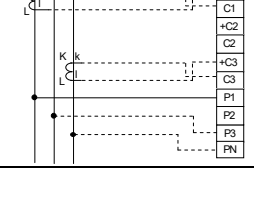
No.	Power Factor (Input)	At balanced load ($V_{1N}=V_{3N}$ (or V_{2N}), $I_1=I_3$ (or I_2))											Connection (Note 1)						
		Phase Angle Display				Active Power Display		Voltage Display			Current Display			Voltage		Current		Connection	
		$\angle V_{1N}$	$\angle V_{3N}$	$\angle I_1$	$\angle I_3$	W_1	W_3	V_{1N}	V_{3N}	V_{13}	I_1	I_N	I_3	1	N	3	1 side CT		3 side CT
7	LEAD 0.707	0	0	315	135	W_1 =Positive value W_3 =Negative value	$V_{1N}>V_{3N}=V_{13}$	$I_1=I_3$ $I_N=0$	P1	P3	PN	+C1-C1 Normal	+C3-C3 Normal	Reverse connection between terminals P3 and PN 					
	LEAD 0.866			330	150														
	1.000			0	180														0
	LAG 0.866			30	210														0
	LAG 0.707			45	225														0
8	LEAD 0.707	0	180	135	315	W_1 =Negative value W_3 =Negative value	$V_{1N}=V_{3N}<V_{13}$	$I_1=I_3$ $I_N=0$	P3	PN	P1	+C1-C1 Normal	+C3-C3 Normal	Reverse connection between terminals P1 and P3 					
	LEAD 0.866			150	330														
	1.000			180	0														0
	LAG 0.866			210	30														0
	LAG 0.707			225	45														0
9	LEAD 0.707	0	0	315	135	W_1 =Positive value W_3 =Negative value	$V_{1N}=V_{13}<V_{3N}$	$I_1=I_3$ $I_N=0$	P3	P1	PN	+C1-C1 Normal	+C3-C3 Normal	Voltage are connected the order of P3, P1, and PN terminals 					
	LEAD 0.866			330	150														
	1.000			0	180														0
	LAG 0.866			30	210														0
	LAG 0.707			45	225														0
10	LEAD 0.707	0	0	135	315	W_1 =Negative value W_3 =Positive value	$V_{1N}>V_{3N}=V_{13}$	$I_1=I_3$ $I_N=0$	PN	P3	P1	+C1-C1 Normal	+C3-C3 Normal	Voltage are connected the order of PN, P3, and P1 terminals 					
	LEAD 0.866			150	330														
	1.000			180	0														0
	LAG 0.866			210	30														0
	LAG 0.707			225	45														0
11	LEAD 0.707	0	0	135	135	W_1 =Negative value W_3 =Negative value	$V_{1N}>V_{3N}=V_{13}$	$I_1=I_3<I_N$	P1	P3	PN	+C1-C1 Reverse	+C3-C3 Normal	P3 and PN terminals are reversed and 1 side CT is reversed. 					
	LEAD 0.866			150	150														
	1.000			180	180														0
	LAG 0.866			210	210														0
	LAG 0.707			225	225														0
12	LEAD 0.707	0	0	315	315	$W_1>W_3$	$V_{1N}>V_{3N}=V_{13}$	$I_1=I_3<I_N$	P1	P3	PN	+C1-C1 Normal	+C3-C3 Reverse	P3 and PN terminals are reversed and 3 side CT is reversed. 					
	LEAD 0.866			330	330														
	1.000			0	0														0
	LAG 0.866			30	30														0
	LAG 0.707			45	45														0
13	LEAD 0.707	0	0	135	315	W_1 =Negative value W_3 =Positive value	$V_{1N}>V_{3N}=V_{13}$	$I_1=I_3$ $I_N=0$	P1	P3	PN	+C1-C1 Reverse	+C3-C3 Reverse	P3 and PN terminals are reversed, and both of CTs are reversed. 					
	LEAD 0.866			150	330														
	1.000			180	0														0
	LAG 0.866			210	30														0
	LAG 0.707			225	45														0

9. Appendix

9.2. A List of Examples for Incorrect Wiring Display

9.2.3. 1-phase 3-wire System

No.	Power Factor (Input)	At balanced load ($V_{1N}=V_{3N}$ (or V_{2N}), $I_1=I_3$ (or I_2))											Connection (Note 1)						
		Phase Angle Display				Active Power Display		Voltage Display			Current Display			Voltage		Current		Connection	
		$\angle V_{1N}$	$\angle V_{3N}$	$\angle I_1$	$\angle I_3$	W_1	W_3	V_{1N}	V_{3N}	V_{13}	I_1	I_N	I_3	1	N	3	1 side CT		3 side CT
14	LEAD 0.707	0	0	0	0	$W_1 < W_3$	$V_{1N} = V_{13} < V_{3N}$	$I_1 = I_3 < I_N$	PN	P1	P3	+C1-C1 Reverse	+C3-C3 Normal	<p>P1 and PN terminals are reversed and 1 side CT is reversed.</p>					
	LEAD 0.866																	330	330
	1.000																	30	30
	LAG 0.866																	45	45
	LAG 0.707																	45	45
15	LEAD 0.707	0	0	180	180	$W_1 = \text{Negative value}$ $W_3 = \text{Negative value}$	$V_{1N} = V_{13} < V_{3N}$	$I_1 = I_3 < I_N$	PN	P1	P3	+C1-C1 Normal	+C3-C3 Reverse	<p>P1 and PN terminals are reversed and 3 side CT is reversed.</p>					
	LEAD 0.866																	150	150
	1.000																	210	210
	LAG 0.866																	225	225
	LAG 0.707																	225	225
16	LEAD 0.707	0	0	0	180	$W_1 = \text{Positive value}$ $W_3 = \text{Negative value}$	$V_{1N} = V_{13} < V_{3N}$	$I_1 = I_3$ $I_N = 0$	PN	P1	P3	+C1-C1 Reverse	+C3-C3 Reverse	<p>P1 and PN terminals are reversed and both of CTs reversed.</p>					
	LEAD 0.866																	330	150
	1.000																	30	210
	LAG 0.866																	45	225
	LAG 0.707																	45	225
17	LEAD 0.707	0	0	0	180	$W_1 = \text{Negative value}$ $W_3 = \text{Negative value}$	$V_{1N} = V_{13} < V_{3N}$	$I_1 = I_3 < I_N$	P3	P1	PN	+C1-C1 Reverse	+C3-C3 Normal	<p>Voltage are connected the order of P3, P1, and PN terminals, and 1 side CT is reversed.</p>					
	LEAD 0.866																	150	150
	1.000																	210	210
	LAG 0.866																	225	225
	LAG 0.707																	225	225
18	LEAD 0.707	0	0	0	0	$W_1 < W_3$	$V_{1N} = V_{13} < V_{3N}$	$I_1 = I_3 < I_N$	P3	P1	PN	+C1-C1 Normal	+C3-C3 Reverse	<p>Voltage are connected the order of P3, P1, and PN terminals, and 3 side CT is reversed.</p>					
	LEAD 0.866																	330	330
	1.000																	30	30
	LAG 0.866																	45	45
	LAG 0.707																	45	45
19	LEAD 0.707	0	0	180	0	$W_1 = \text{Negative value}$ $W_3 = \text{Positive value}$	$V_{1N} = V_{13} < V_{3N}$	$I_1 = I_3$ $I_N = 0$	P3	P1	PN	+C1-C1 Reverse	+C3-C3 Reverse	<p>Voltage are connected the order of P3, P1, and PN terminals, and Both of CTs are reversed.</p>					
	LEAD 0.866																	150	330
	1.000																	210	30
	LAG 0.866																	225	45
	LAG 0.707																	225	45
20	LEAD 0.707	0	0	0	0	$W_1 > W_3$	$V_{1N} > V_{3N} = V_{13}$	$I_1 = I_3 < I_N$	PN	P3	P1	+C1-C1 Reverse	+C3-C3 Normal	<p>Voltage are connected the order of PN, P3, and P1 terminals, and 1 side CT is reversed.</p>					
	LEAD 0.866																	330	330
	1.000																	30	30
	LAG 0.866																	45	45
	LAG 0.707																	45	45

9. Appendix

9.2. A List of Examples for Incorrect Wiring Display

9.2.3. 1-phase 3-wire System

No.	Power Factor (Input)	At balanced load ($V_{1N}=V_{3N}$ (or V_{2N}), $I_1=I_3$ (or I_2))											Connection (Note 1)					
		Phase Angle Display				Active Power Display		Voltage Display			Current Display			Voltage		Current		Connection
		$\angle V_{1N}$	$\angle V_{3N}$	$\angle I_1$	$\angle I_3$	W_1	W_3	V_{1N}	V_{3N}	V_{13}	I_1	I_N	I_3	1	N	3	1 side CT	
21	LEAD 0.707	0	0	135	135	W_1 =Negative value W_3 =Negative value	$V_{1N}>V_{3N}=V_{13}$	$I_1=I_3 < I_N$	PN	P3	P1	+C1-C1 Normal	+C3-C3 Reverse	<p>Voltage are connected the order of PN, P3, and P1 terminals, and 3 side CT is reversed.</p>				
	LEAD 0.866			150	150													
	1.000			180	180													
	LAG 0.866			210	210													
	LAG 0.707			225	225													
22	LEAD 0.707	0	0	315	135	W_1 =Positive value W_3 =Negative value	$V_{1N}>V_{3N}=V_{13}$	$I_1=I_3$ $I_N=0$	PN	P3	P1	+C1-C1 Reverse	+C3-C3 Reverse	<p>Voltage are connected the order of PN, P3, and P1 terminals, and both of CTs are reversed.</p>				
	LEAD 0.866			330	150													
	1.000			0	180													
	LAG 0.866			30	210													
	LAG 0.707			45	225													
23	LEAD 0.707	0	180	315	315	W_1 =Positive value W_3 =Negative value	$V_{1N}=V_{3N}<V_{13}$	$I_1=I_3 < I_N$	P3	PN	P1	+C1-C1 Reverse	+C3-C3 Normal	<p>P1 and P3 terminals are reversed and 1 side CT is reversed.</p>				
	LEAD 0.866			330	330													
	1.000			0	0													
	LAG 0.866			30	30													
	LAG 0.707			45	45													
24	LEAD 0.707	0	180	135	135	W_1 =Negative value W_3 =Positive value	$V_{1N}=V_{3N}<V_{13}$	$I_1=I_3 < I_N$	P3	PN	P1	+C1-C1 Normal	+C3-C3 Reverse	<p>P1 and P3 terminals are reversed and 3 side CT is reversed.</p>				
	LEAD 0.866			150	150													
	1.000			180	180													
	LAG 0.866			210	210													
	LAG 0.707			225	225													
25	LEAD 0.707	0	180	315	135	$W_1=W_3$	$V_{1N}=V_{3N}<V_{13}$	$I_1=I_3$ $I_N=0$	P3	PN	P1	+C1-C1 Reverse	+C3-C3 Reverse	<p>P1 and P3 terminals are reversed and both of CTs are reversed.</p>				
	LEAD 0.866			330	150													
	1.000			0	180													
	LAG 0.866			30	210													
	LAG 0.707			45	225													
26	LEAD 0.707	0	180	135	135	W_1 =Negative value W_3 =Positive value	$V_{1N}=V_{3N}<V_{13}$	$I_1=I_3 < I_N$	P1	PN	P3	+C3-C3 Normal	+C1-C1 Reverse	<p>Both of CTs switch to each other, and the terminals '+C1' and 'C1' are reversed.</p>				
	LEAD 0.866			150	150													
	1.000			180	180													
	LAG 0.866			210	210													
	LAG 0.707			225	225													
27	LEAD 0.707	0	180	315	315	W_1 =Positive value W_3 =Negative value	$V_{1N}=V_{3N}<V_{13}$	$I_1=I_3 < I_N$	P1	PN	P3	+C3-C3 Reverse	+C1-C1 Normal	<p>Both of CTs switch to each other, and the terminals '+C3' and 'C3' are reversed.</p>				
	LEAD 0.866			330	330													
	1.000			0	0													
	LAG 0.866			30	30													
	LAG 0.707			45	45													

9. Appendix

9.2. A List of Examples for Incorrect Wiring Display

9.2.3. 1-phase 3-wire System

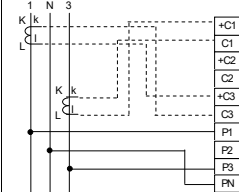
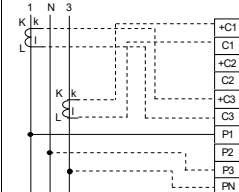
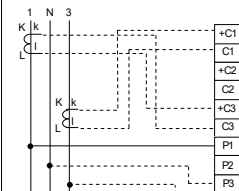
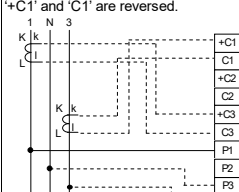
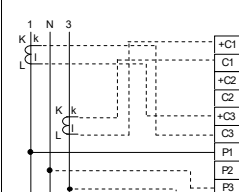
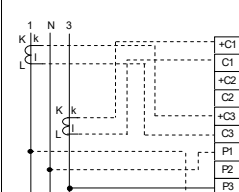
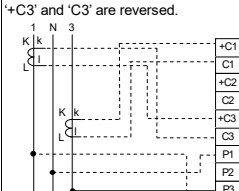
No.	Power Factor (Input)	At balanced load ($V_{1N}=V_{3N}$ (or V_{2N}), $I_1=I_3$ (or I_2))											Connection (Note 1)					
		Phase Angle Display				Active Power Display		Voltage Display			Current Display			Voltage		Current		Connection
		$\angle V_{1N}$	$\angle V_{3N}$	$\angle I_1$	$\angle I_3$	W_1	W_3	V_{1N}	V_{3N}	V_{13}	I_1	I_N	I_3	1	N	3	1 side CT	
28	LEAD 0.707			315	135	$W_1=W_3$	$V_{1N}=V_{3N}<V_{13}$	$I_1=I_3$ $I_N=0$	P1	PN	P3	+C3-C3 Reverse	+C1-C1 Reverse	<p>Both of CTs are switched and reversed each other.</p> 				
	LEAD 0.866			330	150													
	1.000	0	180	0	180													
	LAG 0.866			30	210													
	LAG 0.707			45	225													
29	LEAD 0.707			135	315	W_1 =Negative value W_3 =Positive value	$V_{1N}>V_{3N}=V_{13}$	$I_1=I_3$ $I_N=0$	P1	P3	PN	+C3-C3 Normal	+C1-C1 Normal	<p>P3 and PN terminals are reversed, and both of CTs are switched to each other.</p> 				
	LEAD 0.866			150	330													
	1.000	0	0	180	0													
	LAG 0.866			210	30													
	LAG 0.707			225	45													
30	LEAD 0.707			135	135	W_1 =Negative value W_3 =Negative value	$V_{1N}>V_{3N}=V_{13}$	$I_1=I_3<I_N$	P1	P3	PN	+C3-C3 Reverse	+C1-C1 Normal	<p>P3 and PN are reversed, in addition, both of CTs are switched to each other, and the '+C3' and 'C3' are reversed.</p> 				
	LEAD 0.866			150	150													
	1.000	0	0	180	180													
	LAG 0.866			210	210													
	LAG 0.707			225	225													
31	LEAD 0.707			315	315	$W_1>W_3$	$V_{1N}>V_{3N}=V_{13}$	$I_1=I_3<I_N$	P1	P3	PN	+C3-C3 Normal	+C1-C1 Reverse	<p>P3 and PN are reversed, in addition, both of CTs are switched to each other, and the '+C1' and 'C1' are reversed.</p> 				
	LEAD 0.866			330	330													
	1.000	0	0	0	0													
	LAG 0.866			30	30													
	LAG 0.707			45	45													
32	LEAD 0.707			315	135	W_1 =Positive value W_3 =Negative value	$V_{1N}>V_{3N}=V_{13}$	$I_1=I_3$ $I_N=0$	P1	P3	PN	+C3-C3 Reverse	+C1-C1 Reverse	<p>P3 and PN are reversed, in addition, both of CTs are switched and reversed each other.</p> 				
	LEAD 0.866			330	150													
	1.000	0	0	0	180													
	LAG 0.866			30	210													
	LAG 0.707			45	225													
33	LEAD 0.707			315	135	W_1 =Positive value W_3 =Negative value	$V_{1N}=V_{3N}<V_{13}$	$I_1=I_3$ $I_N=0$	PN	P1	P3	+C3-C3 Normal	+C1-C1 Normal	<p>P1 and PN terminals are reversed, and both of CTs are switched to each other.</p> 				
	LEAD 0.866			330	150													
	1.000	0	0	0	180													
	LAG 0.866			30	210													
	LAG 0.707			45	225													
34	LEAD 0.707			315	315	$W_1<W_3$	$V_{1N}=V_{13}<V_{3N}$	$I_1=I_3<I_N$	PN	P1	P3	+C3-C3 Reverse	+C1-C1 Normal	<p>P1 and PN are reversed, in addition, both of CTs are switched to each other, and the '+C3' and 'C3' are reversed.</p> 				
	LEAD 0.866			330	330													
	1.000	0	0	0	0													
	LAG 0.866			30	30													
	LAG 0.707			45	45													

9. Appendix

9.2. A List of Examples for Incorrect Wiring Display

9.2.3. 1-phase 3-wire System

No.	Power Factor (Input)	At balanced load ($V_{1N}=V_{3N}$ (or V_{2N}), $I_1=I_3$ (or I_2))											Connection (Note 1)					
		Phase Angle Display				Active Power Display		Voltage Display			Current Display			Voltage		Current		Connection
		$\angle V_{1N}$	$\angle V_{3N}$	$\angle I_1$	$\angle I_3$	W_1	W_3	V_{1N}	V_{3N}	V_{13}	I_1	I_N	I_3	1	N	3	1 side CT	
35	LEAD 0.707	0	0	135	135	W_1 =Negative value W_3 =Negative value	$V_{1N}=V_{13}<V_{3N}$	$I_1=I_3<I_N$	PN	P1	P3	+C3-C3 Normal	+C1-C1 Reverse	<p>P1 and PN are reversed, in addition, both of CTs are switched to each other, and the '+C1' and 'C1' are reversed.</p>				
	LEAD 0.866			150	150													
	1.000			180	180													
	LAG 0.866			210	210													
	LAG 0.707			225	225													
36	LEAD 0.707	0	0	135	315	W_1 =Negative value W_3 =Positive value	$V_{1N}=V_{13}<V_{3N}$	$I_1=I_3$ $I_N=0$	PN	P1	P3	+C3-C3 Reverse	+C1-C1 Reverse	<p>P1 and PN are reversed, in addition, both of CTs are switched and reversed each other.</p>				
	LEAD 0.866			150	330													
	1.000			180	0													
	LAG 0.866			210	30													
	LAG 0.707			225	45													
37	LEAD 0.707	0	0	135	315	W_1 =Negative value W_3 =Positive value	$V_{1N}=V_{13}<V_{3N}$	$I_1=I_3$ $I_N=0$	P3	P1	PN	+C3-C3 Normal	+C1-C1 Normal	<p>Voltage are connected the order of P3- P1- PN, and both of CTs are switched to each other.</p>				
	LEAD 0.866			150	330													
	1.000			180	0													
	LAG 0.866			210	30													
	LAG 0.707			225	45													
38	LEAD 0.707	0	0	135	135	W_1 =Negative value W_3 =Negative value	$V_{1N}=V_{13}<V_{3N}$	$I_1=I_3<I_N$	P3	P1	PN	+C3-C3 Reverse	+C1-C1 Normal	<p>Voltage are connected the order of P3- P1- PN, both of CTs switch to each other, and '+C3' and 'C3' are reversed.</p>				
	LEAD 0.866			150	150													
	1.000			180	180													
	LAG 0.866			210	210													
	LAG 0.707			225	225													
39	LEAD 0.707	0	0	315	315	$W_1<W_3$	$V_{1N}=V_{13}<V_{3N}$	$I_1=I_3<I_N$	P3	P1	PN	+C3-C3 Normal	+C1-C1 Reverse	<p>Voltage are connected the order of P3- P1- PN, both of CTs switch to each other, and '+C3' and 'C3' are reversed.</p>				
	LEAD 0.866			330	330													
	1.000			0	0													
	LAG 0.866			30	30													
	LAG 0.707			45	45													
40	LEAD 0.707	0	0	315	135	W_1 =Positive value W_3 =Negative value	$V_{1N}=V_{13}<V_{3N}$	$I_1=I_3$ $I_N=0$	P3	P1	PN	+C3-C3 Reverse	+C1-C1 Reverse	<p>Voltage are connected the order of P3- P1- PN, both of CTs are switched and reversed each other.</p>				
	LEAD 0.866			330	150													
	1.000			0	180													
	LAG 0.866			30	210													
	LAG 0.707			45	225													
41	LEAD 0.707	0	0	315	135	W_1 =Positive value W_3 =Negative value	$V_{1N}>V_{3N}=V_{13}$	$I_1=I_3$ $I_N=0$	PN	P3	P1	+C3-C3 Normal	+C1-C1 Normal	<p>Voltage are connected the order of PN-P3- P1, and both of CTs are switched to each other.</p>				
	LEAD 0.866			330	150													
	1.000			0	180													
	LAG 0.866			30	210													
	LAG 0.707			45	225													

9. Appendix

9.2. A List of Examples for Incorrect Wiring Display

9.2.3. 1-phase 3-wire System

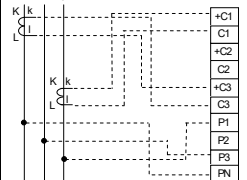
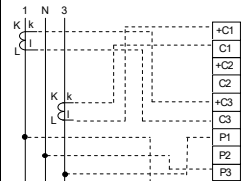
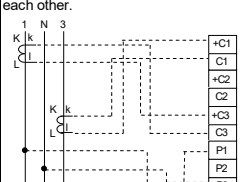
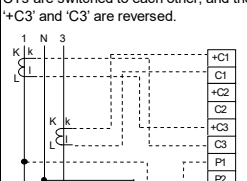
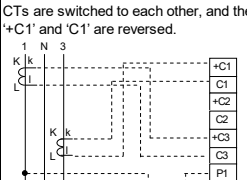
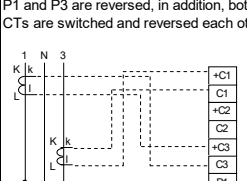
No.	Power Factor (Input)	At balanced load ($V_{1N}=V_{3N}$ (or V_{2N}), $I_1=I_3$ (or I_2))											Connection (Note 1)					
		Phase Angle Display				Active Power Display		Voltage Display			Current Display			Voltage		Current		Connection
		$\angle V_{1N}$	$\angle V_{3N}$	$\angle I_1$	$\angle I_3$	W_1	W_3	V_{1N}	V_{3N}	V_{13}	I_1	I_N	I_3	1	N	3	1 side CT	
42	LEAD 0.707			315	315	$W_1 > W_3$	$V_{1N} > V_{3N} = V_{13}$	$I_1 = I_3 < I_N$	PN	P3	P1	+C3-C3 Reverse	+C1-C1 Normal	<p>Voltage are connected the order of PN-P3-P1, both of CTs switch to each other, and '+C3' 'C3' are reversed.</p> 				
	LEAD 0.866			330	330													
	1.000	0	0	0	0													
	LAG 0.866			30	30													
	LAG 0.707			45	45													
43	LEAD 0.707			135	135	$W_1 = \text{Negative value}$ $W_3 = \text{Negative value}$	$V_{1N} > V_{3N} = V_{13}$	$I_1 = I_3 < I_N$	PN	P3	P1	+C3-C3 Normal	+C1-C1 Reverse	<p>Voltage are connected the order of PN-P3-P1, both of CTs switch to each other, and '+C1' 'C1' are reversed.</p> 				
	LEAD 0.866			150	150													
	1.000	0	0	180	180													
	LAG 0.866			210	210													
	LAG 0.707			225	225													
44	LEAD 0.707			135	315	$W_1 = \text{Negative value}$ $W_3 = \text{Positive value}$	$V_{1N} > V_{3N} = V_{13}$	$I_1 = I_3$ $I_N = 0$	PN	P3	P1	+C3-C3 Reverse	+C1-C1 Reverse	<p>Voltage are connected the order of PN-P3-P1, both of CTs are switched and reversed each other.</p> 				
	LEAD 0.866			150	330													
	1.000	0	0	180	0													
	LAG 0.866			210	30													
	LAG 0.707			225	45													
45	LEAD 0.707			315	315	$W_1 = \text{Positive value}$ $W_3 = \text{Negative value}$	$V_{1N} = V_{3N} < V_{13}$	$I_1 = I_3 < I_N$	P3	PN	P1	+C3-C3 Reverse	+C1-C1 Normal	<p>P1 and P3 are reversed, in addition, both of CTs are switched to each other, and the '+C3' and 'C3' are reversed.</p> 				
	LEAD 0.866			330	330													
	1.000	0	180	0	0													
	LAG 0.866			30	30													
	LAG 0.707			45	45													
46	LEAD 0.707			135	135	$W_1 = \text{Negative value}$ $W_3 = \text{Positive value}$	$V_{1N} = V_{3N} < V_{13}$	$I_1 = I_3 < I_N$	P3	PN	P1	+C3-C3 Normal	+C1-C1 Reverse	<p>P1 and P3 are reversed, in addition, both of CTs are switched to each other, and the '+C1' and 'C1' are reversed.</p> 				
	LEAD 0.866			150	150													
	1.000	0	180	180	180													
	LAG 0.866			210	210													
	LAG 0.707			225	225													
47	LEAD 0.707			135	315	$W_1 = \text{Negative value}$ $W_3 = \text{Negative value}$	$V_{1N} = V_{3N} < V_{13}$	$I_1 = I_3$ $I_N = 0$	P3	PN	P1	+C3-C3 Reverse	+C1-C1 Reverse	<p>P1 and P3 are reversed, in addition, both of CTs are switched and reversed each other.</p> 				
	LEAD 0.866			150	330													
	1.000	0	180	180	0													
	LAG 0.866			210	30													
	LAG 0.707			225	45													

Note1: The above examples for incorrect wiring are typical. Extreme cases are excluded such as burnout or destruction of the instrument, VT, or CT caused by voltage application to a current circuit or current application to a voltage circuit.

mitsubishi Electronic Multi-Measuring Instrument

Please refer to our website for service network.

Our website address: <https://www.mitsubishielectric.com/fa/>

mitsubishi ELECTRIC CORPORATION
HEAD OFFICE: TOKYO BUILDING, 2-7-3, MARUNOUCHI, CHIYODA-KU, TOKYO 100-8310, JAPAN