

**New Product
News**

June 2019

No.M023

MDU BREAKER WS-V Series and W&WS Series



Features of Mitsubishi MDU Breakers

① Space saving and construction cost saving

◆ Construction cost saving

Wiring work for measuring devices is unnecessary, and the construction period and cost can be reduced.

[Example of wiring for combined measuring devices (before introduction)]

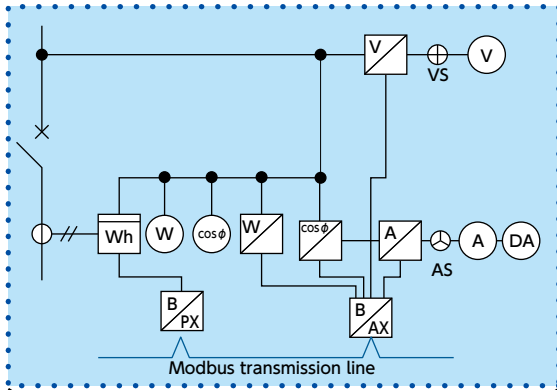

Construction	Conventional combination of devices		Introduction of MDU breaker
Wiring	CT line	Ammeter, wattmeter, power factor meter, harmonic current meter, current demand meter, electric energy meter, transducers (current, electric power, power factor, harmonic current, current demand)	Unnecessary
	Voltage line	Voltmeter, wattmeter, power factor meter, electric energy meter, transducers (voltage, electric power, power factor)	Unnecessary
	Auxiliary power supply	Transducers (current, voltage, electric power, power factor, harmonic current, current demand), transmission device	Necessary
	Measurement signal line	Transmission device input	Unnecessary
	Transmission line	Transmission device	Necessary
Devices installed	16 units		1 unit

* The MDU breakers are not designed for electric power supply and demand based on Measurement Act.

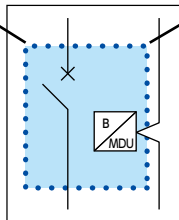

[After introduction of MDU breaker]

◆ Space saving

The board installation area can be reduced, and the space can be effectively used.

If the MDU breaker is introduced when the board is renewed, upgrading can be expected by adding the measuring and display functions within the area of the standard circuit breaker.

② Sophisticated and multifunctional

◆ Circuit monitoring

The breaker constantly monitors the load current and, if the load current exceeds the preset value, outputs an alarm, and the operator can take measures. Accordingly, unnecessary tripping does not occur, and power can be continuously supplied. Alarms on the circuit are given by using LCD and LED. A simple monitoring system can be realized.

◆ Preventive equipment maintenance

When the breaker trips, the cause and fault current are recorded in the nonvolatile memory.

For example:

Monitoring of overload on motor and transformer

The PAL (pre-alarm) function monitors the load current and issues a preliminary alarm when the load current reaches a certain control level (adjustable from 70 to 100% of the rated current).

Example of introduction of MDU breaker (monitoring of electric power at substation and on production line)

Uses

Measurement of electric power at assembly plant

- The relationship between production and power usage is clarified, and the data is used, first of all, for activities for reducing the amount of wasted electricity.
- The breaker is used as a tool for visualized control of energy-saving activities to support planning, confirming, analyzing and evaluating the energy-saving activities.

Effect of introduction

- Automation of periodic measurement
 - Automatic measurement by the hour
 - Daily manual measurement requires to read and record the values measured at many points and enter the values into a personal computer.
- Automation of detailed measurement
 - Detailed measurement of electric power in specific equipment (for example, measurement every 15 minutes for 1 week) can be automated through setting on a personal computer.

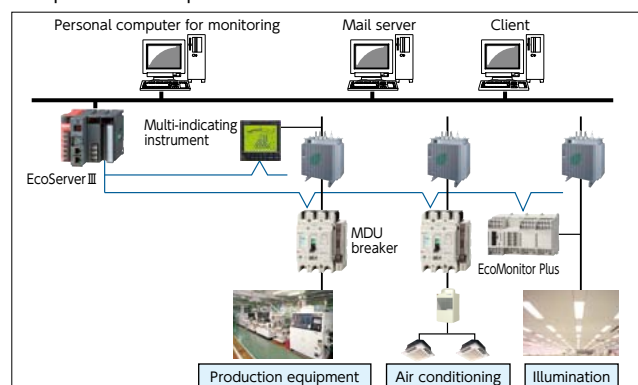

Evolving MDU Breakers

① Downsizing

◆ Breakers with the same outside dimensions as the standard circuit breakers are realized by using the front LCD for displaying circuit information.

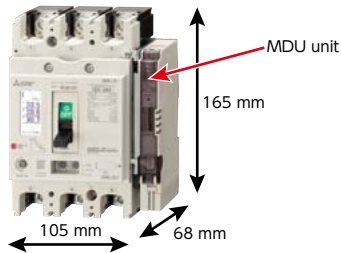

(Dimensions in the case where the built-in display unit of the 250 A frame is separately mounted)

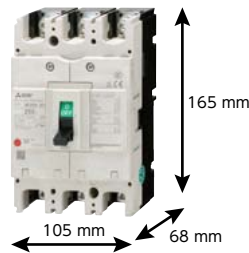

② Improved visibility

◆ When an alarm or fault occurs, the LCD backlight changes from white to red.

◆ The display direction can be switched.

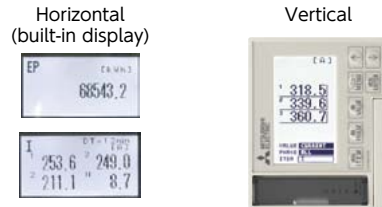
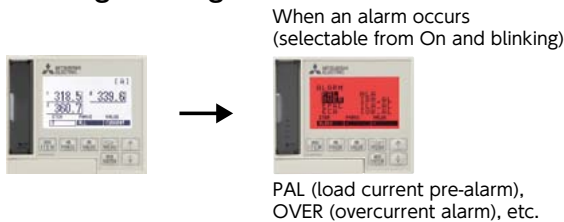

③ Improved operability

◆ The multi-function display screen reduces the number of operations.



The measurement item to be checked can be quickly displayed from the measurement item list.

The conditions of **three phases are displayed in one window** and can be seen at a glance.

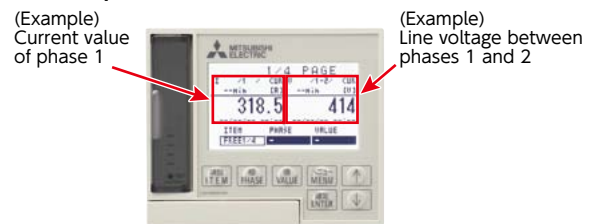

Since **any two elements can be constantly set in one window**, the number of repeated operations can be reduced. (Up to 8 elements in four windows can be set.)

④ Increased breaking capacity

Type	NF250-SW with MDU	NF250-SEV with MDU
AC [V]	Rated breaking capacity [kA] Icu/Ics	
690	—	8/8
500	15/8	18/18
440	25/13	36/36
415	30/15	36/36
400	30/15	36/36
380	30/15	36/36
230	50/25	85/85
200	50/25	85/85

Type	NF400-SEP with MDU NF600-SEP with MDU NF800-SEP with MDU	NF400-SEW with MDU NF800-SEW with MDU
AC [V]	Rated breaking capacity [kA] Icu/Ics	
690	10/10	10/10
500	30/30	30/30
440	42/42	42/42
415	45/45	50/50
400	45/45	50/50
380	45/45	50/50
230	85/85	85/85
200	85/85	85/85

[Applicable standards] JIS C 8201-2-1 Ann.1, JIS C 8201-2-1 Ann.2, IEC 60947-2

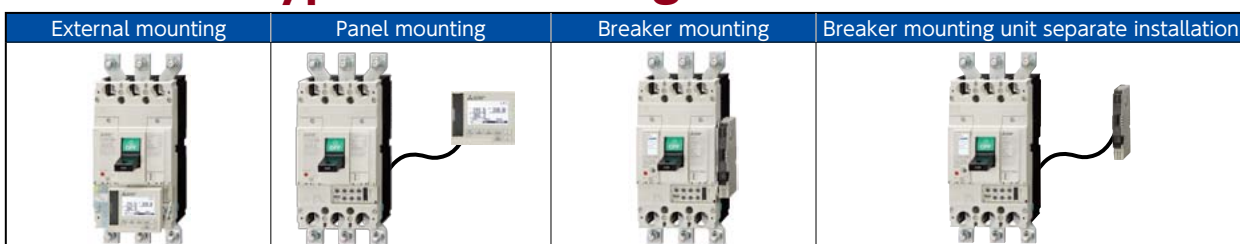

⑤ Various types of mounting



The standard MDU connecting cable for panel mounting and breaker mounting separate unit is 2 m long. (The cable length, 0.5 m, 3 m, 5 m or 10 m, can be specified.)

Specifications for breakers

Classification	Symbol
Standard	⊙
Semi-standard	○
Make-to-order	△

Type		Molded-case Circuit Breaker																
Frame A		250				400				630				800				
Type name		NF250-SEV with MDU	NF250-HEV with MDU	NF400-SEV with MDU	NF400-HEV with MDU	NF800-SEV with MDU	NF800-HEV with MDU	NF800-SEV with MDU	NF800-HEV with MDU	NF800-SEV with MDU	NF800-HEV with MDU	NF800-SEV with MDU	NF800-HEV with MDU	NF800-SEV with MDU	NF800-HEV with MDU			
Image																		
Rated current In (A)		250				400				630				800				
Current setting Ir (A)		125 - 250 adjustable (12.5 A steps)				200 - 400 adjustable				300 - 630 adjustable				400 - 800 adjustable				
Number of poles		3	4	3	4	3	4	3	4	3	4	3	4	3	4	3	4	
Phase line		3-pole type: 3-phase 3-wire 4-pole type: 3-phase 4-wire (3-pole type can be used as a 1-phase 2-wire unit.)																
Rated insulation voltage Ui (V)		690				690				690				690				
Rated short-circuit breaking capacity (kA)	JIS C 8201-2-1 Ann.1 JIS C 8201-2-1 Ann.2 IEC 60947-2 (Icu/Ics)	AC	690 V	8/8	10/8	10/10	10/10	10/10	10/10	10/10	15/15	10/10	15/15	10/10	15/15	10/10	15/15	
			500 V	18/18	30/23	30/30	50/50	30/30	50/50	30/30	50/50	30/30	50/50	30/30	50/50	30/30	50/50	
			440 V	36/36	50/50	42/42	65/65	42/42	65/65	42/42	65/65	42/42	65/65	42/42	65/65	42/42	65/65	
			415 V	36/36	70/70	50/50	70/70	50/50	70/70	50/50	70/70	50/50	70/70	50/50	70/70	50/50	70/70	
			400 V	36/36	75/75	50/50	70/70	50/50	70/70	50/50	70/70	50/50	70/70	50/50	70/70	50/50	70/70	
	GB/T 14048.2 (Icu/Ics)	AC	380 V	36/36	75/75	50/50	70/70	50/50	70/70	50/50	70/70	50/50	70/70	50/50	70/70	50/50	70/70	
			230 V	85/85	100/100	85/85	100/100	85/85	100/100	85/85	100/100	85/85	100/100	85/85	100/100	85/85	100/100	
			200 V	85/85	100/100	85/85	100/100	85/85	100/100	85/85	100/100	85/85	100/100	85/85	100/100	85/85	100/100	
			415 V	36/36	70/70	50/50	70/70	50/50	70/70	50/50	70/70	50/50	70/70	50/50	70/70	50/50	70/70	
			400 V	36/36	75/75	50/50	70/70	50/50	70/70	50/50	70/70	50/50	70/70	50/50	70/70	50/50	70/70	
380 V	36/36	75/75	50/50	70/70	50/50	70/70	50/50	70/70	50/50	70/70	50/50	70/70	50/50	70/70				
230 V	85/85	100/100	85/85	100/100	85/85	100/100	85/85	100/100	85/85	100/100	85/85	100/100	85/85	100/100				
Rated impulse withstand voltage Uimp (kV)		8				8				8				8				
Current		AC				AC				AC				AC				
Suitability for isolation		Compatible				Compatible				Compatible				Compatible				
Reverse connection		Possible				Possible				Possible				Possible				
Number of operating cycles	Without current	25,000				6,000				6,000				4,000				
	With current (440VAC)	10,000				1,000				1,000				500				
Utilization category		A				B				B				B				
Rated short-time resistant current Icw kA (0.25s)		-				5				7.6				9.6				
Pollution degree		3				3				3				3				
EMC environment condition (environment A or B)		A				A				A				A				
Overall dimensions (mm)	a	105	140	105	140	140	185	140	185	210	280	210	280	210	280	210	280	
	b	165				257				275				275				
	c	68				103				103				103				
	ca	92				155				155				155				
Weight of product with front connection type MDU mounted on body (kg)		1.8	2.3	1.8	2.3	6.2	8	6.2	8	10.7	13.8	10.7	13.8	11.1	14.4	11.1	14.4	
MDU mounting method (*1)		External mounting, panel mounting, breaker mounting, breaker mounting unit separate installation																
Installation and connections	Front	(F)	○	△	○	△	○	△	○	△	○	△	○	△	○	△		
	Rear (*2)	(B)	○	△	○	△	○	△	○	△	○	△	○	△	○	△		
Cassette-type accessories (*4)	Alarm switch (AL)	○ (*3)	△	○ (*3)	△	○ (*3)	△	○ (*3)	△	○ (*3)	△	○ (*3)	△	○ (*3)	△	○ (*3)	△	
	Auxiliary switch (AX)	○ (*3)	△	○ (*3)	△	○ (*3)	△	○ (*3)	△	○ (*3)	△	○ (*3)	△	○ (*3)	△	○ (*3)	△	
	Shunt trip (SHT)	○ (*3)	△	○ (*3)	△	○ (*3)	△	○ (*3)	△	○ (*3)	△	○ (*3)	△	○ (*3)	△	○ (*3)	△	
	Undervoltage trip (LVT)	○	△	○	△	○	△	○	△	○	△	○	△	○	△	○	△	
	AL, AX, AL+AX for MDU transmission	○ (*3)	△	○ (*3)	△	○ (*3)	△	○ (*3)	△	○ (*3)	△	○ (*3)	△	○ (*3)	△	○ (*3)	△	
	With lead-wire terminal block (SLT)	○	△	○	△	○	△	○	△	○	△	○	△	○	△	○	△	
	Horizontal lead wire terminal block (LT)	○	△	○	△	○	△	○	△	○	△	○	△	○	△	○	△	
	Alarm contact output (*5)	Pre-alarm (PAL)	△ PAL 1a				△ PAL 1a				△ PAL 1a				△ PAL 1a			
	Cause of fault (TI)		-				△ PAL 1a, OAL 1a				△ PAL 1a, OAL 1a				△ PAL 1a, OAL 1a			
	External accessories	Electrical operation device (*6) (NFM)	△ Can be installed only in the case of panel mounting.				△ Can be installed only in the case of panel mounting. Cannot be installed when the alarm contact output is provided.				△ Can be installed only in the case of panel mounting. Cannot be installed when the alarm contact output is provided.				△ Can be installed only in the case of panel mounting. Cannot be installed when the alarm contact output is provided.			
Mechanical interlock (MI) (*7)		Panel mounting	△ Can be installed only in the case of panel mounting.				△ Can be installed only in the case of panel mounting.				△ Can be installed only in the case of panel mounting.				△ Can be installed only in the case of panel mounting.			
		For embedded type	△ Can be installed only in the case of panel mounting.				△ Can be installed only in the case of panel mounting.				△ Can be installed only in the case of panel mounting.				△ Can be installed only in the case of panel mounting.			
Handle lock device		Breaker direct mounting	△ (*8)	-	△ (*8)	-	△ (*8)	-	△ (*8)	-	△ (*8)	-	△ (*8)	-	△ (*8)	-	△ (*8)	-
		LC	○	△	○	△	○	△	○	△	○	△	○	△	○	△	○	△
HL		○	△	○	△	○	△	○	△	○	△	○	△	○	△	○	△	
Operating handle		HL-S	△ Can be installed only in the case of panel mounting.				△ Can be installed only in the case of panel mounting.				△ Can be installed only in the case of panel mounting.				△ Can be installed only in the case of panel mounting.			
		(F)	△ Can be installed only in the case of panel mounting.				△ Can be installed only in the case of panel mounting.				△ Can be installed only in the case of panel mounting.				△ Can be installed only in the case of panel mounting.			
		(V)	△ Can be installed only in the case of panel mounting.				△ Can be installed only in the case of panel mounting.				△ Can be installed only in the case of panel mounting.				△ Can be installed only in the case of panel mounting.			
		(S) (*7)	△ Can be installed only in the case of panel mounting.				△ Can be installed only in the case of panel mounting.				△ Can be installed only in the case of panel mounting.				△ Can be installed only in the case of panel mounting.			
Terminal cover	(C) (*7)	-				-				-				-				
	TC-L	○ (*9)	△ (*10)	○ (*9)	△ (*10)	○ (*9)	△ (*10)	○ (*9)	△ (*10)	○ (*9)	△ (*10)	○ (*9)	△ (*10)	○ (*9)	△ (*10)	○ (*9)	△ (*10)	
	TC-S	○ (*9)	△ (*10)	○ (*9)	△ (*10)	○ (*9)	△ (*10)	○ (*9)	△ (*10)	○ (*9)	△ (*10)	○ (*9)	△ (*10)	○ (*9)	△ (*10)	○ (*9)	△ (*10)	
	TTC	○ (*9)	△ (*11)	○ (*9)	△ (*11)	○ (*9)	△ (*11)	○ (*9)	△ (*11)	○ (*9)	△ (*11)	○ (*9)	△ (*11)	○ (*9)	△ (*11)	○ (*9)	△ (*11)	
Rear stud (B-ST)	BTC	○ (*9)	△ (*10)	○ (*9)	△ (*10)	○ (*9)	△ (*10)	○ (*9)	△ (*10)	○ (*9)	△ (*10)	○ (*9)	△ (*10)	○ (*9)	△ (*10)	○ (*9)	△ (*10)	
		○	△	○	△	○	△	○	△	○	△	○	△	○	△	○	△	
Automatic tripping device		Electronic (effective value detection)				Electronic (effective value detection)				Electronic (effective value detection)				Electronic (effective value detection)				
Trip button		Equipped				Equipped				Equipped				Equipped				

- Notes: *1 When the panel mounting is specified, the breaker comes with panel fittings and mounting screws, and the 2 m long connecting cable (standard) is supplied. (The connecting cable length, 0.5 m, 3 m, 5 m or 10 m, can be specified.) When the breaker mounting separate unit is specified, the 2 m long connecting cable (standard) is supplied. (The connecting cable length, 0.5 m, 3 m, 5 m or 10 m, can be specified.) Note that the cutout size in the breaker front plate varies depending on the MDU mounting method.
- *2 The 250 A frame models come with the studs in the package. In the case of the 400 and 800 A frame models, the studs are fitted before shipment. Specify the mounting direction.
- *3 These are cassette-type devices and can be installed by the user.
- *4 When the following devices are installed on the built-in display type, the built-in display unit must be separately mounted.
250 A frame: Accessories with SLT or module on the right pole side
400/630/800 A frame: Accessories on right pole side
- *5 The breaker with alarm contact output is provided with the module on the right side and requires a control power supply (common to 100 to 240 V AC/DC, 50/60 Hz, 5 VA). The PAL output does not operate if the MDU is connected and the control power is not applied to the MDU.
The output method of PAL of the alarm contact output can be set to "self-holding" or "automatic reset" from the MDU. The default setting is "automatic reset."
- *6 For the electrical operation device for 250 A frame, one alarm switch AL (for minute electric current) is used to display tripping. The allowable number of AL is reduced by one. When the alarm contact output is provided, the device cannot be operated.
- *7 It does not have an isolation function except for 400 to 800 A frame models.
- *8 It can be manufactured only in the case of panel mounting.
- *9 For a 250 A frame model with built-in display and PAL, the cover dedicated for the MDU is used. When placing an order only for the terminal cover, add MP to the end of the model name. (Example: TCL-2SV3MP)
- *10 In the case of breaker mounting, the cover dedicated for the MDU is used. When placing an order only for the terminal cover, add -MDUB to the end of the model name. (Example: TCL-2SV3-MDUB)
- *11 250 A frame 4-pole models are not provided with TTC for breaker mounting.
- Remarks: The breaking capacities shown in the

--	--	--	--

 columns are indicated on the breakers.

Specifications for Measuring Display Units (MDU)

● Specifications for Measuring Display Units (MDU)

The measurement and display items vary depending on the model and A frame.

Measurement/stored item (accuracy)(*)1)(*)2)(*)3)		Function	Display	Storage (*4)	With electric energy pulse output (*5)	With CC-Link communication	With MODBUS communication	Remarks
Load current (±1.0%)	Present value	Each phase	○	—	—	○	○	
		Total (average) (*7)	—	—	—	○	○	
	Present demand value (*6)	Each phase	○	—	—	○	○	
		Max. phase	○	—	—	○	○	
	Max. demand value of all phases		○	○	—	○	○	
Time of occurrence of max. demand value of all phases		○	○	—	○	○		
Line voltage (±1.0%)	Present value	Between each two lines	○	—	—	○	○	
		Total (average) (*7)	○	—	—	○	○	
	Max. value between all lines	○	○	—	○	○		
Time of occurrence of max. value between all lines		○	○	—	○	○		
Harmonic current (±2.5%)	Present value	Fundamental wave of each phase	○	—	—	○	○	
		Individual harmonic current of each phase	○	—	—	○	○	
		Total harmonic current of each phase (*8)	○	—	—	○	○	
	Max. fundamental wave value of all phases		○	○	—	○	○	
	Time of occurrence of max. fundamental wave value of all phases		○	○	—	○	○	
	Max. value of individual harmonic current of all phases		○	○	—	○	○	
	Time of occurrence of max. value of individual harmonic current of all phases		○	○	—	○	○	
	Demand value (*6)	Total harmonic current of each phase (*8)	○	—	—	○	○	
		Max. total demand value of all phases	○	○	—	○	○	
	Time of occurrence of max. total demand value of all phases		○	○	—	○	○	
Total distortion rate of each phase		○	—	—	○	○		
Individual content of each phase		○	—	—	○	○		
Electric power (±1.5%)	Present value	Present value	○	—	—	○	○	
		Max. value	○	○	—	○	○	
	Time of occurrence of max. value		○	○	—	○	○	
Reactive power (±2.5%)	Present value	Present value	○	—	—	○	○	
		Max. value	○	○	—	○	○	
	Time of occurrence of max. value		○	○	—	○	○	
Electric energy (±2.0%) (*9)	Integrated value		○	○	○	○	○	Value accumulated to the present after the previous reset
	Amount for last one house		○	—	—	○	○	
	Max. value of amount for one hour		○	○	—	○	○	
	Time of occurrence of max. value of amount for one hour		○	○	—	○	○	
Reactive electric energy (±3.0%) (*9)	Integrated value		○	○	○	○	○	Value accumulated to the present after the previous reset
	Amount for last one house		○	—	—	○	○	
	Max. value of amount for one hour		○	○	—	○	○	
	Time of occurrence of max. value of amount for one hour		○	○	—	○	○	
Cause of fault (*10)	Fault current (accuracy: ±15%)		○	○	—	○	○	Information on and causes of faults after the previous reset or the latest fault (Continuous monitoring)
	Cause of fault		○	○	—	○	○	
Power factor (±5.0%)	Present value	Present value	○	—	—	○	○	
		Max. value	○	○	—	○	○	
	Time of occurrence of max. value		○	○	—	○	○	
Frequency (±2.5%)	Present value		○	—	—	○	○	
Phase sequence	—		○	—	—	○	○	Except 250 A frame
Status of breaker	Tripping status of breaker (AL)		—	—	—	○	○	When the alarm switch for MDU transmission (option) is installed
	ON/OFF status of breaker (AX)		—	—	—	○	○	When the auxiliary switch for MDU transmission (option) is installed
	Number of times of tripping of breaker		—	○	—	○	○	When the alarm switch for MDU transmission (option) is installed
	Number of times of opening/closing of breaker		—	○	—	○	○	When the auxiliary switch for MDU transmission (option) is installed
Breaker alarms (*11)	PAL, OVER, IDM_AL, ILA_AL, IUB_AL		○	—	—	○	○	The LC display, transmission and contact output of the PAL function of 250 A frame model are activated when the PAL module (option)
	Neutral wire open phase alarm (NLA)		○	—	—	—	—	The neutral wire open phase alarm is displayed only. When the phase wire system is set to 1-phase 3-wire system, the function is turned on. Rated operating overvoltage: 135 V AC Operating time: 1 s
	Time setting		○	—	—	○	○	It is necessary to re-set at the initial setting and after power failure (no power failure compensation). The default setting is 2 min.
Initial setting	Demand time limit setting (*6)		○	○	—	○	○	The time limit can be set in one-minute increments in the range from 0 to 15 min.
	IDM_AL (current demand alarm)		○	○	—	○	○	The default setting of the function is OFF. Function: ON/OFF Pickup current: 50 to 100% (in 1% steps) Demand time limit: Can be set to 1 to 10 min (1 min steps), 15, 20, 25 or 30 min.
	ILA_AL (current open phase alarm)		○	○	—	○	○	The default setting of the function is OFF. Function: Can be set to ON or OFF. Pickup current: Fixed to 10% (no setting) Operating time: 30 s (no setting)
	IUB_AL (current unbalance alarm)		○	○	—	○	○	The default setting of the function is OFF. Function: Can be set to ON or OFF. Pickup current: Fixed to 30% (no setting) Operating time: 30 s (no setting)
	Phase switching setting		○	○	—	○	○	The default setting is "no phase switching."
	Alarm retention (self-holding/automatic reset) setting		○	○	—	○	○	The default setting is "automatic reset."
	Phase wire system		○	○	—	○	○	The default setting is "3-phase 3-wire" for 3-pole breakers or "3-phase 4-wire" for 4-pole breakers.
	Electric energy arbitrary setting		○	○	—	○	○	
	Reactive electric energy arbitrary setting		○	○	—	○	○	
	Display direction		○	○	—	—	—	The default setting is "horizontal" for mounting on breaker and mounting on panel or "horizontal" for built-in display and separate mounting of built-in display unit.

Notes: *1 The term "each phase" for load current and harmonic current refers to the 1st, 2nd, 3rd or N-th phase. However, the N-th phase applies only to 4-pole breakers. The term "between each two phases" for line voltage refers to "between 1 and 2," "2 and 3," "3 and 1," "1 and N," "2 and N" or "3 and N." However, "between 1 and N," "between 2 and N" and "between 3 and N" apply only to 4-pole breakers.
 *2 This unit measures data every 0.25 s. Therefore, it may not measure the operating current even when a low-order circuit breaker operates.
 *3 The term "each max. value" refers to the largest value during the period from the start of use (the previous reset) to the present.
 *4 Each max. value cannot be individually cleared.
 *5 In the nonvolatile memory, the integrated values of electric energy and reactive electric energy are stored at power failure and every 30 minutes, the fault current and its cause are stored upon occurrence of the fault, each set value is stored when it is set, and others are stored every 30 minutes.
 *6 Every time the electric energy is integrated into a pulse unit (the unit can be set to any of 1 kWh, 10 kWh, 100 kWh, 1000 kWh and 10000 kWh), a pulse is output. The pulse can be counted with a PLC.
 *7 The demand time limit cannot be set individually. The setting is common.
 *8 When the phase wire system is set, the average values of load current and line voltage are calculated as shown below.

Phase wire system	Average present value of current	Average present value of voltage
1-phase 2-wire system	Average present value of current = current of the 3rd phase	Average present value of voltage = voltage between 2 and 3
1-phase 3-wire system	Average present value of current = (current of the 1st phase + current of the 3rd phase)/2	Average present value of voltage = (voltage between 1 and 2 + voltage between 2 and 3)/2
3-phase 3-wire system	Average present value of current = (current of the 1st phase + current of the 2nd phase + current of the 3rd phase)/3	Average present value of voltage = (voltage between 1 and 2 + voltage between 2 and 3 + voltage between 3 and 1)/3

*9 Sum of 3rd to 19th harmonic components excluding fundamental wave components
 *10 The reverse power is not measured.
 *11 When overload or short circuit fault occurs and the current value exceeds the upper limit of the fault current measurement range (rated current 125 to 250 A (adjustable): 4000 A, rated current 50, 60, 75, 100 and 125 A (fixed): 2000 A), some 250 A frame models may not display the cause of the fault or measure the fault current.
 The display of cause of fault caused by instantaneous tripping and this measurement of the fault current are enabled when the AL for MDU transmission (option) is installed.
 *12 The display of alarm on the MDU is automatically reset when the alarm retention setting is "automatic reset." When the alarm retention method is "self-holding," the alarm is self-held. When the setting is "self-holding," the alarm is reset by performing the alarm reset operation (collective reset). "OVER" is automatically reset regardless of the setting.

Remarks: The LCD may have bright spots (spots that are constantly on) and dark spots (spots that do not light) by its nature. The LCD has many display elements, and it is impossible to completely eliminate the occurrence of bright and dark spots. The occurrence of bright and dark spots is not a defect of this product.

● Specifications for Measuring Display Units (MDU)

Item	Specifications	
Data update cycle	250 ms (harmonic current: 2 s)	
Tolerances	Current, voltage: ±1.0% (of rated input) Electric power: ±1.5% (of rated input) Reactive energy: ±2.5% (of rated input) Harmonic current: ±2.5% (of rated input) Power factor ±5.0% Frequency ±2.5% Electric energy ±2.0% (voltage range from 100 V to 440 V, range from 5 to 100% of current rating, power factor 1) Reactive electric energy (voltage range from 100 V to 440 V, range from 10 to 100% of current rating, power factor 0) Fault current ±15% (*1)	
Demand time limit setting range	0 to 15 min (in 1 min steps)	
Measurement rating input	Voltage circuit	440 V (3-phase 4-wire system is applicable only to 4-pole models.)
	Current circuit	Load current/harmonic current: 125 A/250 A/400 A/630 A/ 800 A (Automatically discriminated. Determined according to the A frame of breaker. 125 A when the rated current of 250 A frame is 125 A or less.)
	Frequency	50 Hz/60 Hz (Automatic discrimination of frequency)
Power failure compensation	(1) Wh (integrated value), varh (integrated value)	Stored in the nonvolatile memory
	(2) Max. value	* Wh and varh are stored at power failure and every 30 min. The max. value is stored every 30 min. The setting data is stored when the data is set.
	(3) Setting data	
	Clock	No power failure compensation
Clock accuracy	Error: approx. 1 min/month	
Outside dimensions (unit: mm)	See "Features and outline."	
Control power	Common to 100 to 240 V AC/DC, 50/60 Hz (allowable voltage range: 85% to 110%), 12 VA * Rush current flows transiently when the control power supply is turned on. (Rush current max. value 2 A, current carrying time 1 ms (240 V AC))	
Other functions	Function for switching the measurement phases from 1-3 to 3-1 Self-holding/automatic reset setting function Function for counting the number of times of opening/closing of breaker body (*2), function for counting the number of times of tripping of breaker body (*3).	

Notes: *1 The measurement of fault current caused by instantaneous tripping of the 250A frame breaker is enabled when the alarm switch for MDU transmission (option) is installed on the MDU breaker body.
*2 The function is enabled when the auxiliary switch for MDU transmission (option) is installed on the MDU breaker body.
*3 The function is enabled when the alarm switch for MDU transmission (option) is installed on the MDU breaker body.

[Electric energy pulse output]

Item	Specifications
Output element	Solid state relay (SSR), no-voltage a contact (Ca and Cb terminals: no polarity)
Contact capacity	Common to 24 V DC and 100 to 200 V AC, 20 mA
Output pulse unit	1, 10, 100, 1000 or 10000 kWh/pulse (selectable) (*1)
Output pulse width	0.34 to 0.45 s
Max. wiring length	100 m

Notes: *1 The default setting is 1 kWh/pulse.

[MODBUS communication]

Item	Specifications
Communication system	RS-485/2-wire system/half-duplex communication
Communication protocol	MODBUS-RTU communication (binary data transfer)
Synchronization system	Asynchronous
Connection system	Multi-drop wiring
Transmission rate	2,400, 4,800, 9,600, 19,200, 38,400 bps
Bit length	8 bits
Stop bit	1 bit or 2 bits
Parity bit	ODD, EVEN, NONE
Slave address	1 to 127
Response time	Response is sent 1 sec or less after the completion of receipt of query data.
Termination resistance	120 Ω 1/2 W
Max. transmission distance	1,200 m
Max. number of connected units	31 units/system
Transmission line	SPEV(SB)-MPC-0.2×1P (Mitsubishi Cable Industries, Ltd.) or its equivalent

Note: MODBUS communication is applicable to mounting on breaker and mounting on panel.

[CC-Link communication]

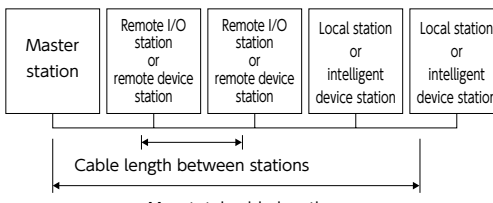
Item	Specifications																		
Communication speed	10 M/5 M/2.5 M/625 k/156 kbps																		
Communication system	Broadcast polling system																		
Synchronization system	Frame synchronization system																		
Coding system	NRZI																		
Transmission format	Conforming to HDLC																		
Number of occupied stations	Remote device occupying one station																		
Number of connected units	Meet the following conditions. Up to 42 units can be connected when only MDU breakers are used. Condition 1 for number of connected units $[(1 \times a) + (2 \times b) + (3 \times c) + (4 \times d)] \leq 64$ a: Number of units occupying 1 station, b: Number of units occupying 2 stations c: Number of units occupying 3 stations, d: Number of units occupying 4 stations Condition 2 for number of connected units $[(16 \times A) + (54 \times B) + (88 \times C)] \leq 2304$ A: number of units with 1 remote I/O station ≤ 64, B: number of remote device stations ≤ 42, C: number of local stations ≤ 26																		
Station No.	Set in the range from 1 to 64. (Set the station No. without fail.)																		
CC-Link version	CC-Link Ver.1.10																		
Max. total cable length and cable length between stations	 <p>Cable compatible with CC-Link Ver.1.10 (110-ohm termination resistance is used.)</p> <table border="1"> <thead> <tr> <th>Communication speed</th> <th>156 kbps</th> <th>625 kbps</th> <th>2.5 Mbps</th> <th>5 Mbps</th> <th>10 Mbps</th> </tr> </thead> <tbody> <tr> <td>Cable length between stations</td> <td colspan="5">0.2 m or more</td> </tr> <tr> <td>Max. total cable length</td> <td>1200 m</td> <td>900 m</td> <td>400 m</td> <td>160 m</td> <td>100 m</td> </tr> </tbody> </table>	Communication speed	156 kbps	625 kbps	2.5 Mbps	5 Mbps	10 Mbps	Cable length between stations	0.2 m or more					Max. total cable length	1200 m	900 m	400 m	160 m	100 m
Communication speed	156 kbps	625 kbps	2.5 Mbps	5 Mbps	10 Mbps														
Cable length between stations	0.2 m or more																		
Max. total cable length	1200 m	900 m	400 m	160 m	100 m														
Connecting cable	Cable compatible with CC-Link Ver.1.10 (shielded 3-core twisted pair cable) * Cables made by different manufacturers can be used if the cables are compatible with Ver.1.10.																		

Note: For more information, refer to the website of CC-Link Partner Association (<http://www.cc-link.org/>).

Operating Characteristics Curves

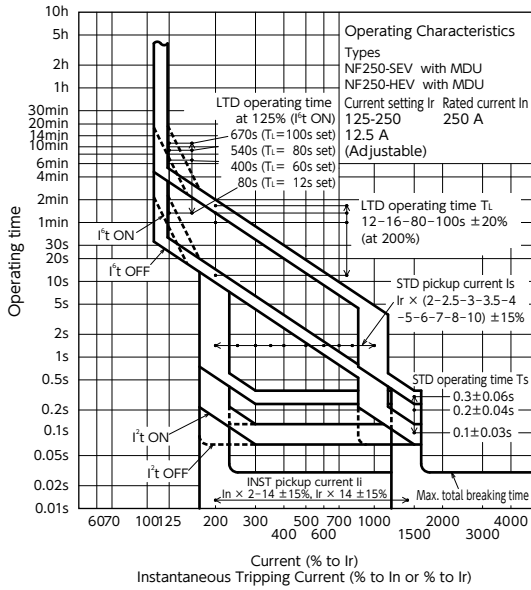

NF250-SEV with MDU
NF250-HEV with MDU

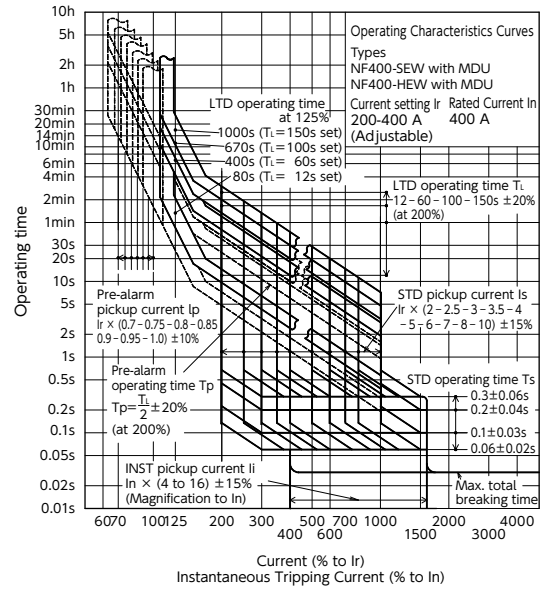

NF400-SEW with MDU
NF400-HEW with MDU

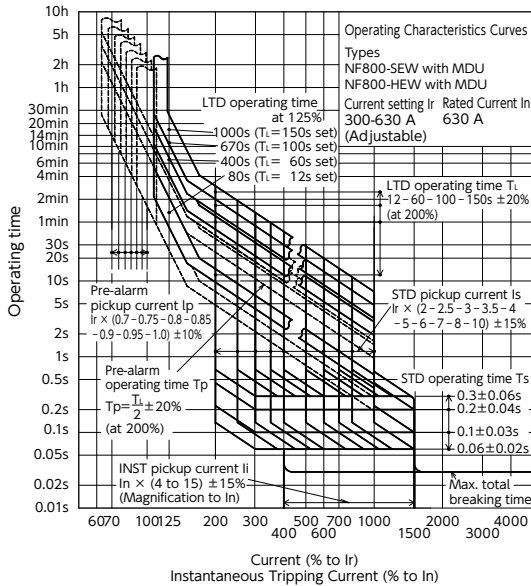

NF800-SEW with MDU (In: 630 A)
NF800-HEW with MDU (In: 630 A)

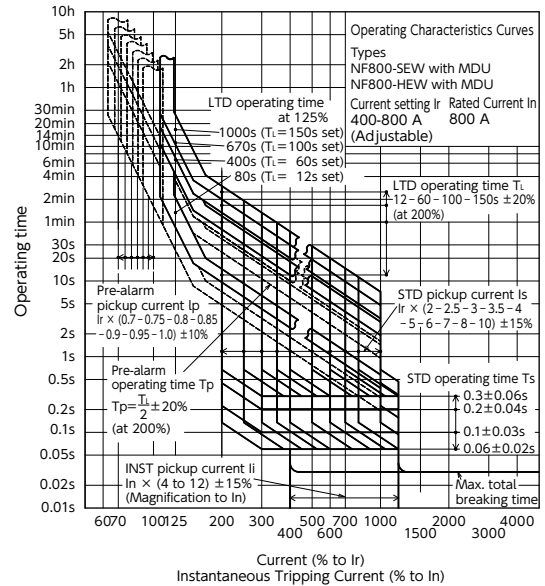

NF800-SEW with MDU (In: 800 A)
NF800-HEW with MDU (In: 800 A)

Current Reducing Curve

NF250-SEV with MDU
NF250-HEV with MDU

NF400-SEW with MDU
NF400-HEW with MDU

NF800-SEW with MDU
NF800-HEW with MDU

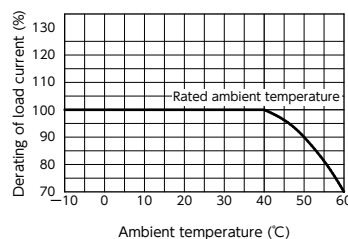

The rated current does not have thermal characteristics.
Reduce the current as shown in the curve on the left chart
if the ambient temperature exceeds 40 °C.

Outline dimensional drawings

NF250-SEV with MDU External mounting
 NF250-HEV with MDU External mounting

Front connection

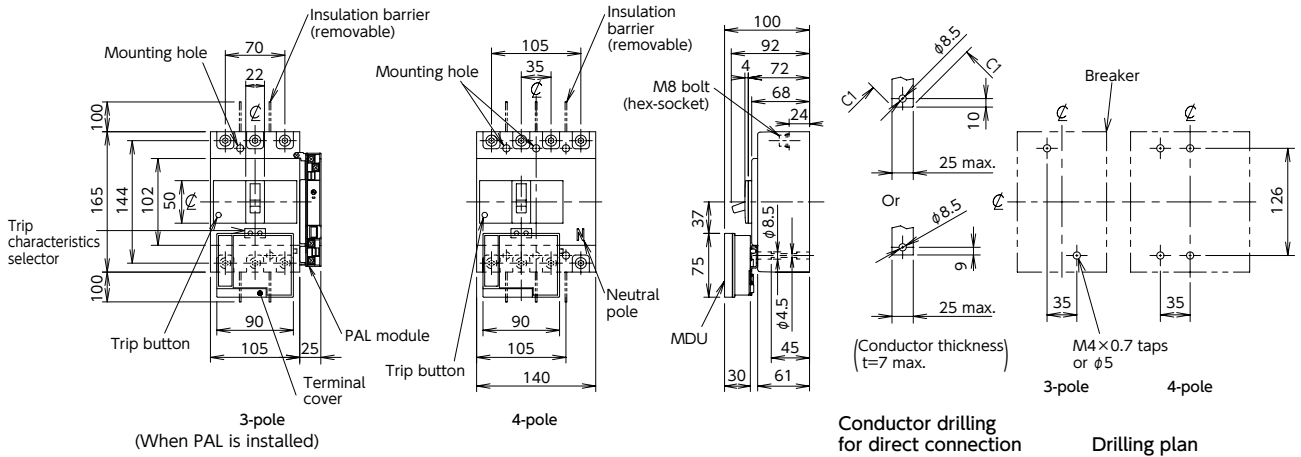

Rear connection

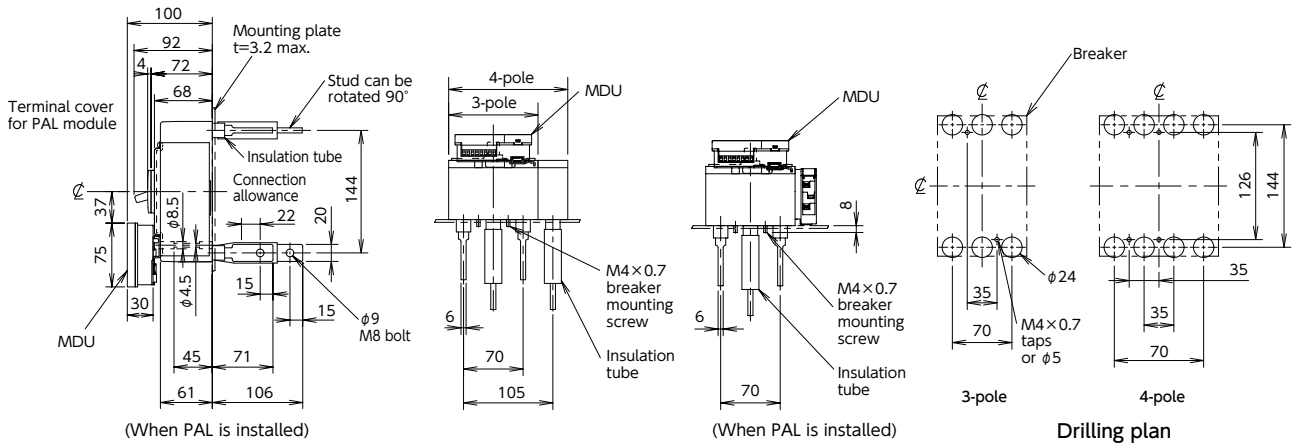

Front-panel cutout

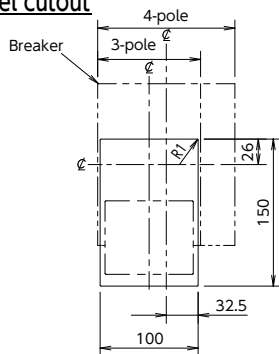

The dimensions include a clearance of 1.0 mm on each side of the breaker frame. (A gap for passing the electric wires to the terminal block is provided on the load side in the case of mounting on breaker.) When the breaker is provided with the CC-Link communication (MDU-BC) or MODBUS communication (MDU-BM), the cutout for mounting on breaker cannot be made in the front plate.

MDU terminal arrangement

In the figure below the terminal cover is removed. Secure the wires with cable clamps, etc.

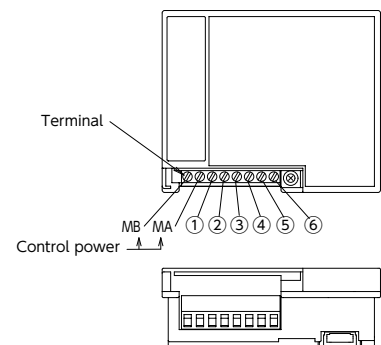

PAL module (option)

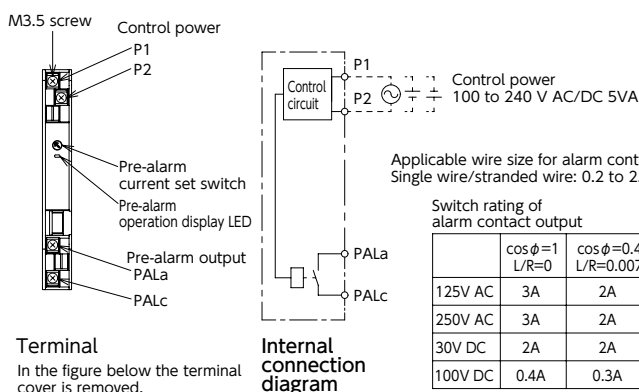

Model	Spec.	①	②	③	④	⑤	⑥
MDU-BN	No transmission	—	FG	—	—	—	—
MDU-BP	Pulse output	—	FG	—	—	Cb	Ca
MDU-BC	CC-Link	—	FG	SLD	DG	DB	DA
MDU-BM	MODBUS	—	FG	SLD	485+	485-	Ter

Outline dimensional drawings

NF250-SEV with MDU Breaker mounting
 NF250-HEV with MDU Breaker mounting

Front connection

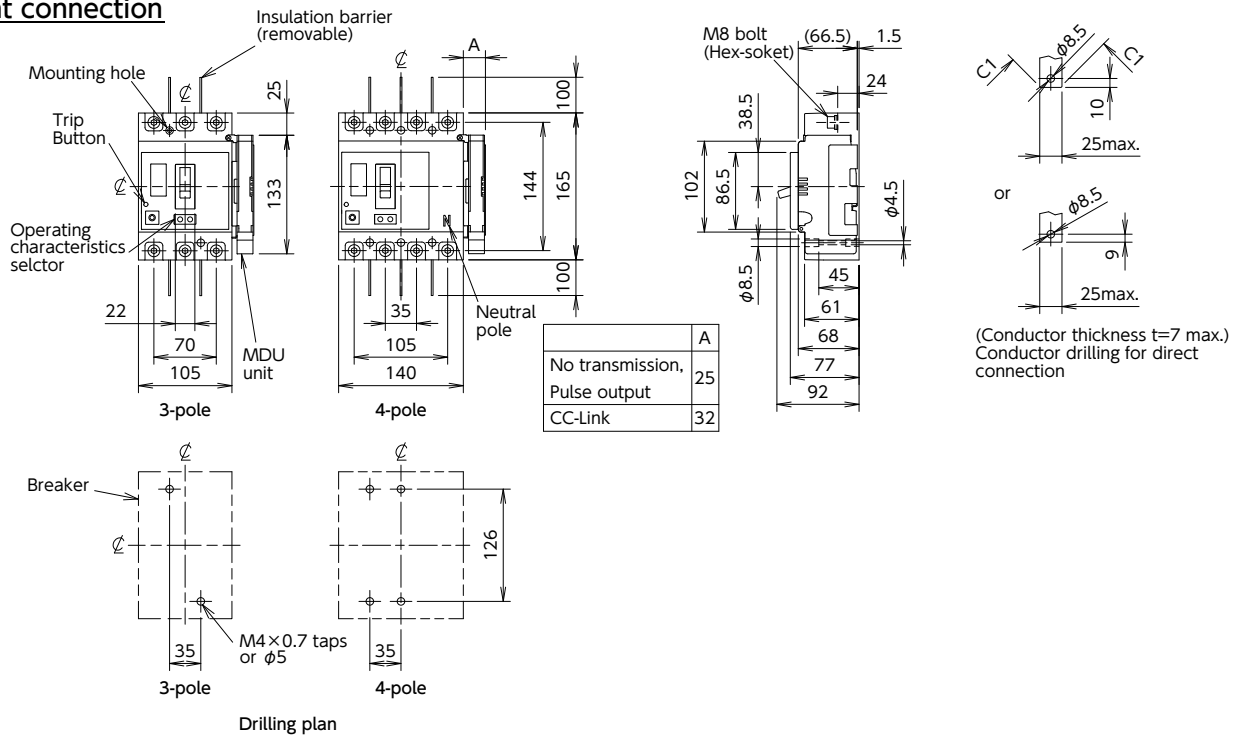

Rear connection

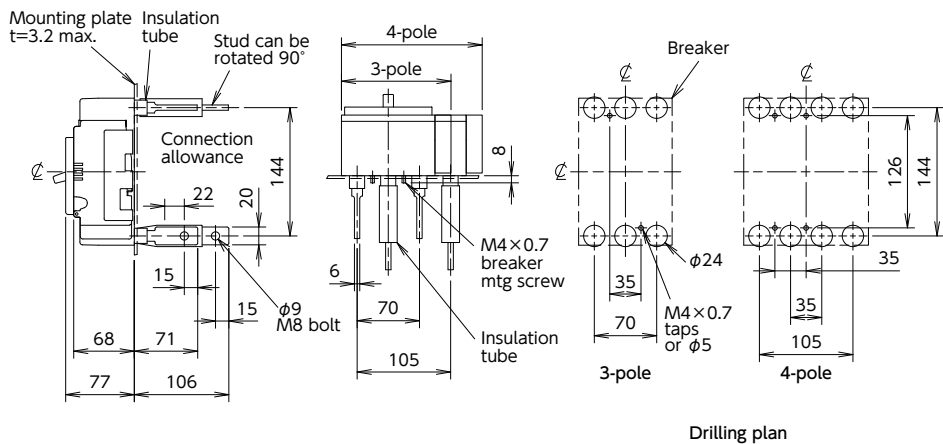

Front-plate cutout

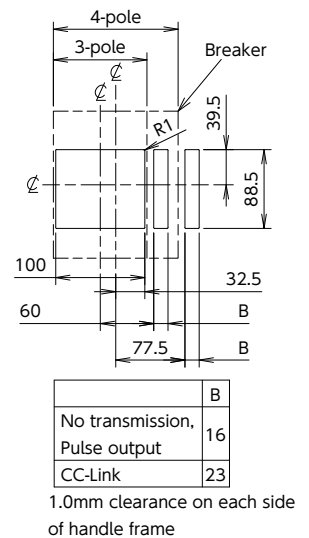

MDU outline

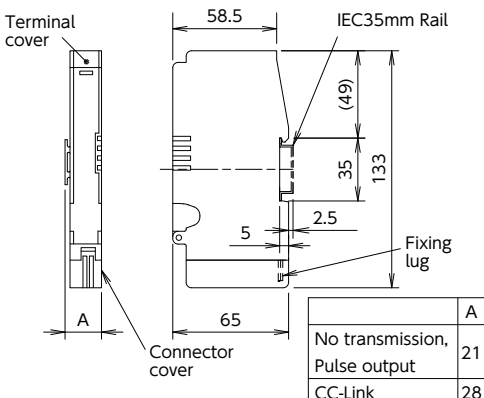

MDU terminal

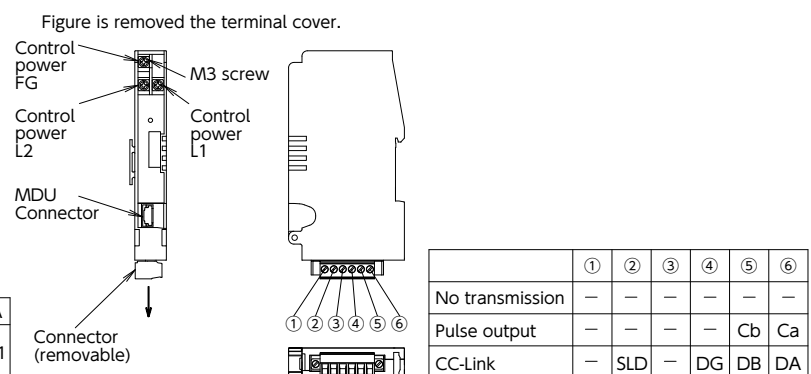

Outline dimensional drawings

NF400-SEW with MDU External mounting
 NF400-HEW with MDU External mounting

Front connection

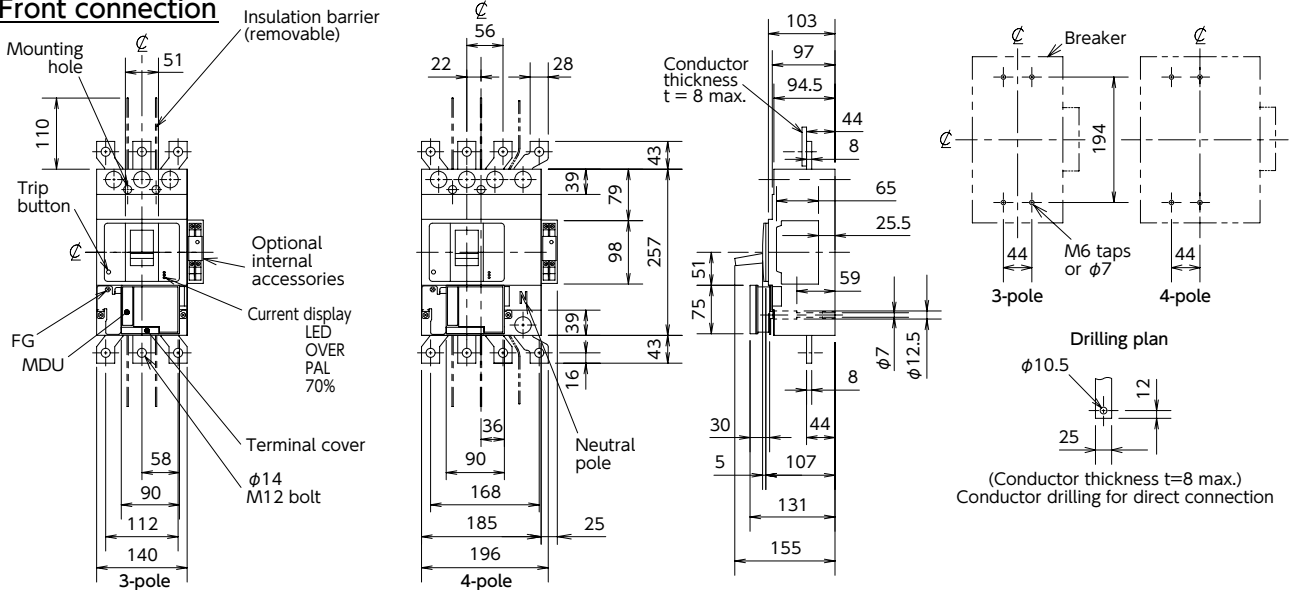

Rear connection

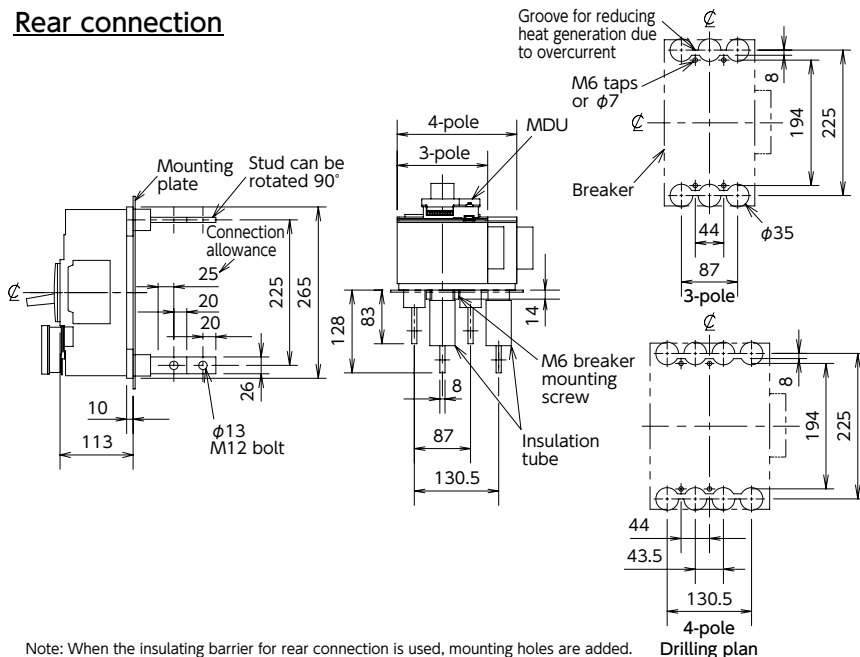

Internal accessories (option)

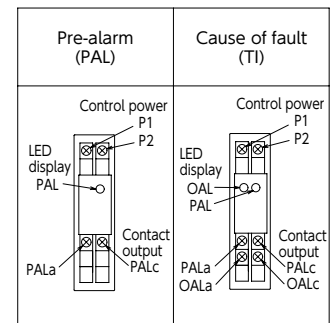

Front-panel cutout

The dimensions include a clearance of 1.0 mm on each side of the breaker frame. (A gap for passing the electric wires to the terminal block is provided on the load side in the case of mounting on breaker.)
 When the breaker is provided with the CC-Link communication (MDU-BC) or MODBUS communication (MDU-BM), the cutout for mounting on breaker cannot be made in the front plate.

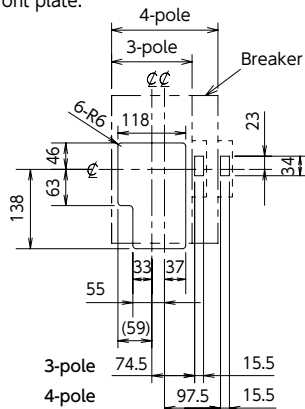

MDU terminal

In the figure below the terminal cover is removed. Secure the wires with cable clamps, etc.

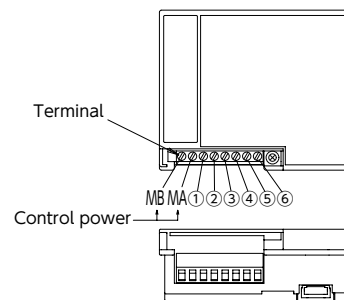

Model	Spec.	①	②	③	④	⑤	⑥
MDU-BN	No transmission	—	FG	—	—	—	—
MDU-BP	Pulse output	—	FG	—	—	Cb	Ca
MDU-BC	CC-Link	—	FG	SLD	DG	DB	DA
MDU-BM	MODBUS	—	FG	SLD	485+	485-	Ter

Outline dimensional drawings

NF400-SEW with MDU Panel mounting
 NF400-HEW with MDU Panel mounting

Front connection

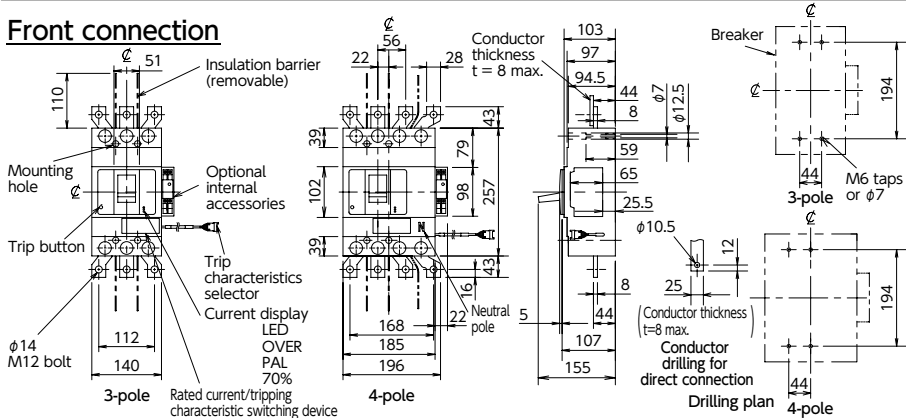

Front-panel cutout

1.0 mm clearance on each side of the handle frame

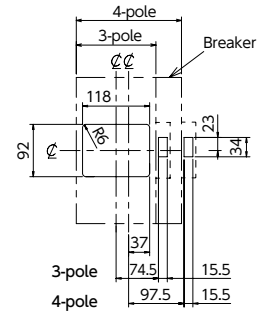

Rear connection

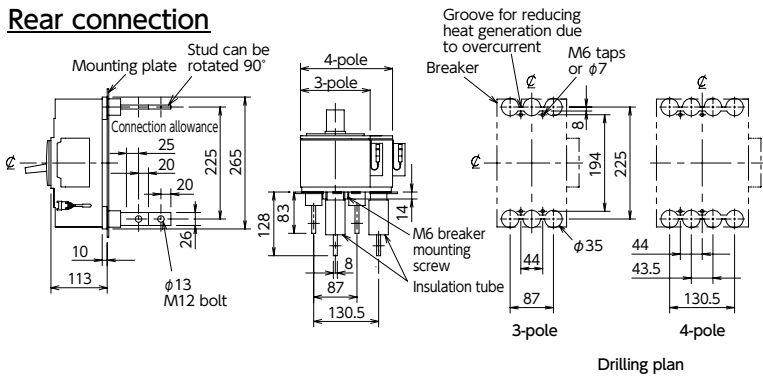

Internal accessories (option)

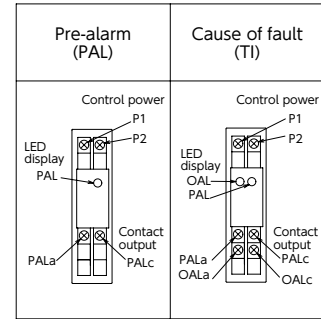

Note: When the insulating barrier for rear connection is used, mounting holes are added.

Mounting on MDU panel

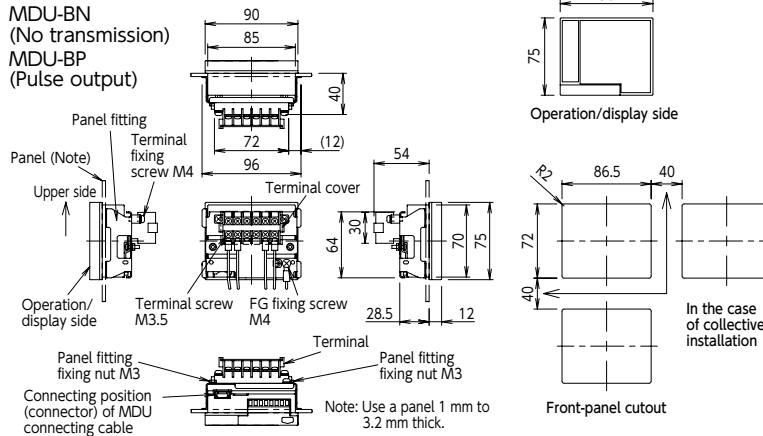

When installing, ensure a distance larger than the following size, and keep a space of 10 cm or more from the distribution line.

MDU terminal arrangement

Secure the wires with cable clamps, etc.

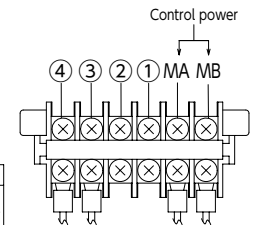

Model	A
NF400-SEW with MDU	244
NF400-HEW with MDU	374

MDU model	Spec.	①	②	③	④
MDU-BN	No transmission	—	—	—	—
MDU-BP	Pulse output	—	—	Cb	Ca

MDU panel mounting position (rear connection)
 Note: In the case of front connection, keep a sufficient distance from the connecting wires and insulating barrier.

Mounting on MDU panel

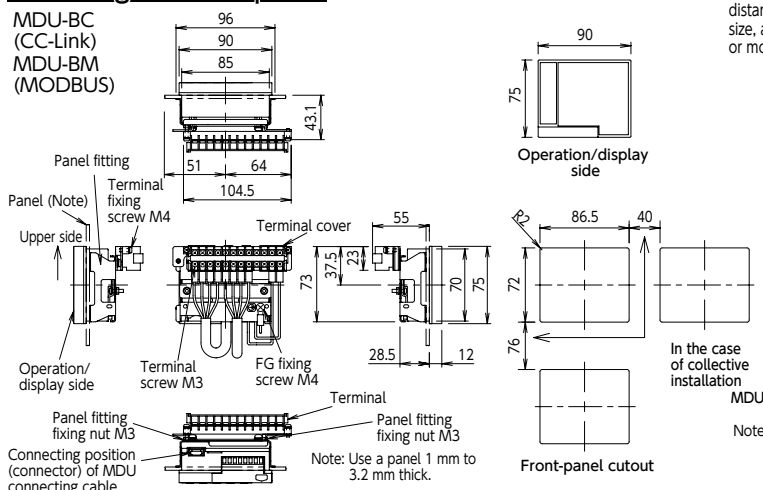

When installing, ensure a distance larger than the following size, and keep a space of 10 cm or more from the distribution line.

MDU terminal arrangement

Secure the wires with cable clamps, etc.

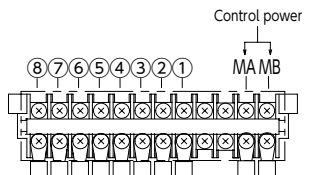

Model	A
NF400-SEW with MDU	263
NF400-HEW with MDU	393

MDU model	Spec.	①	②	③	④	⑤	⑥	⑦	⑧
MDU-BC	CC-Link	SLD	DG	DB	DA	SLD	DG	DB	DA
MDU-BM	MODBUS	SLD	485 ⁺	485 ⁻	Ter	SLD	485 ⁺	485 ⁻	Ter

MDU panel mounting position (rear connection)
 Note: In the case of front connection, keep a sufficient distance from the connecting wires and insulating barrier.

Outline dimensional drawings

NF400-SEW with MDU Breaker mounting
 NF400-HEW with MDU Breaker mounting

Front connection

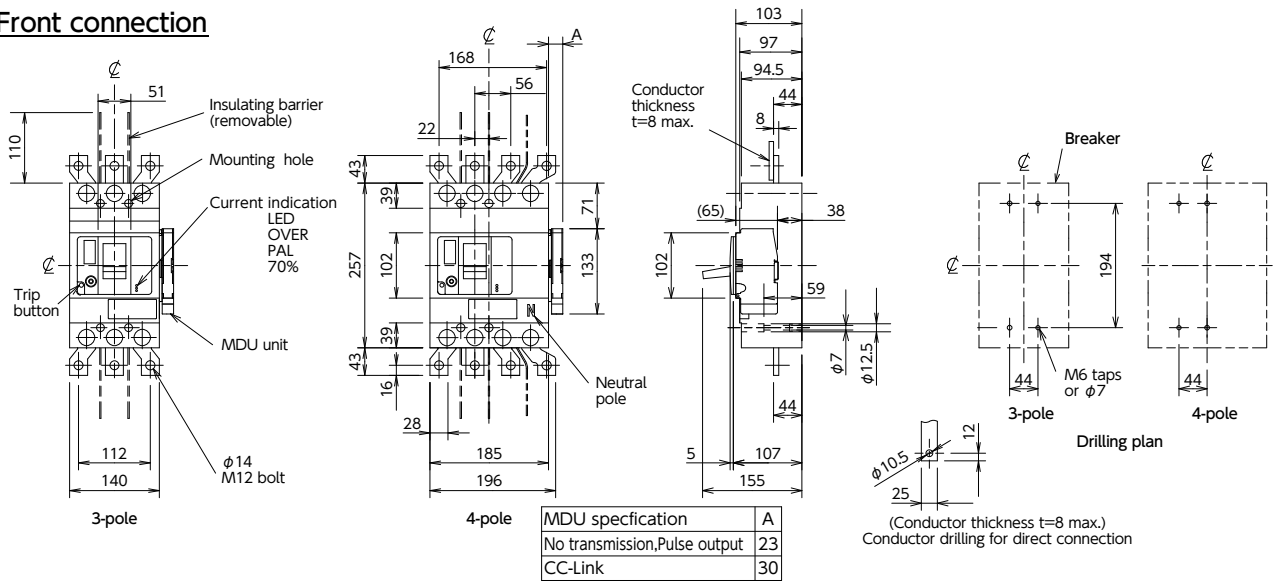

Rear connection

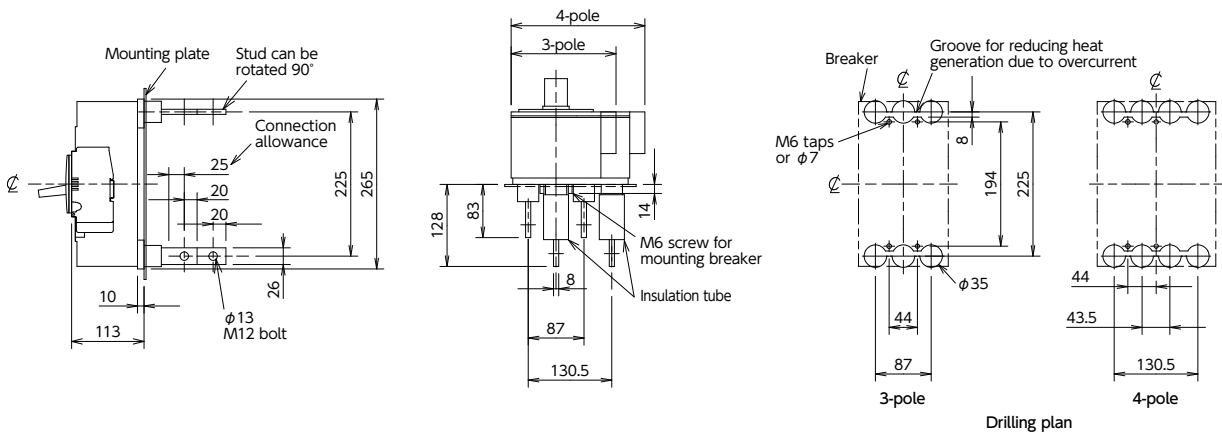

Note: When the insulating barrier for rear connection is used, mounting holes are added.

Front-panel cutout

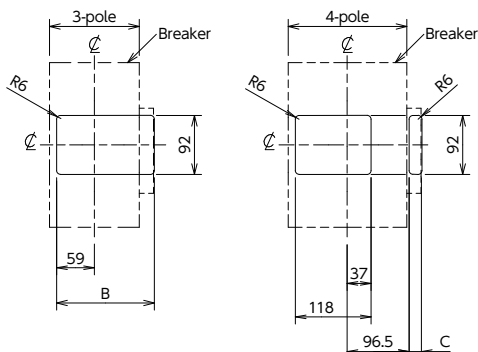

MDU specification	B	C
No transmission, Pulse output	153	20
CC-Link	160	27

MDU unit outline

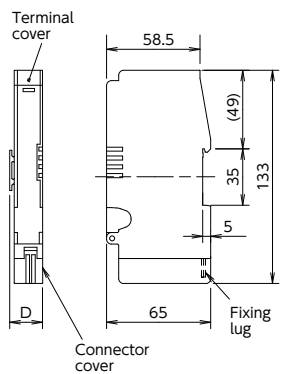

MDU specification	D
No transmission, Pulse output	21
CC-Link	28

MDU unit terminal

The figure is without terminal cover and connector cover.
 Please fix the wiring with clamp etc.

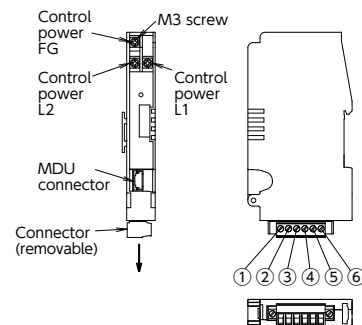

MDU specification	①	②	③	④	⑤	⑥
No transmission	-	-	-	-	-	-
Pulse output	-	-	-	-	Cb	Ca
CC-Link	-	SLD	-	DG	DB	DA

Outline dimensional drawings

NF800-SEW with MDU External mounting
 NF800-HEW with MDU External mounting

Front connection

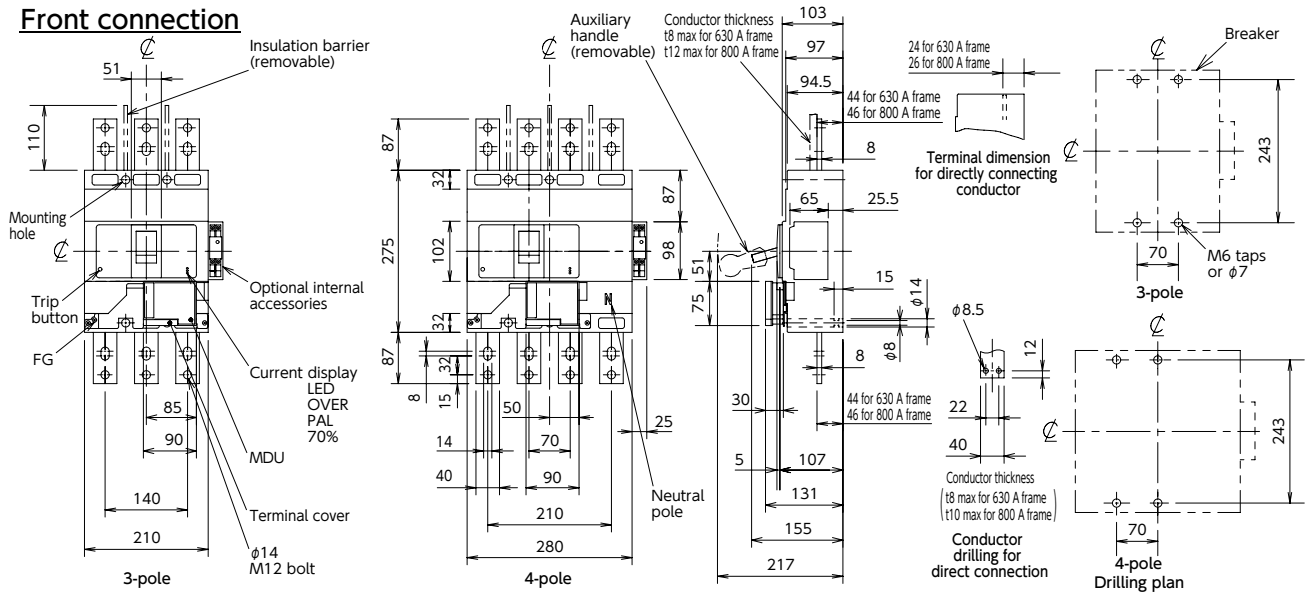

Rear connection

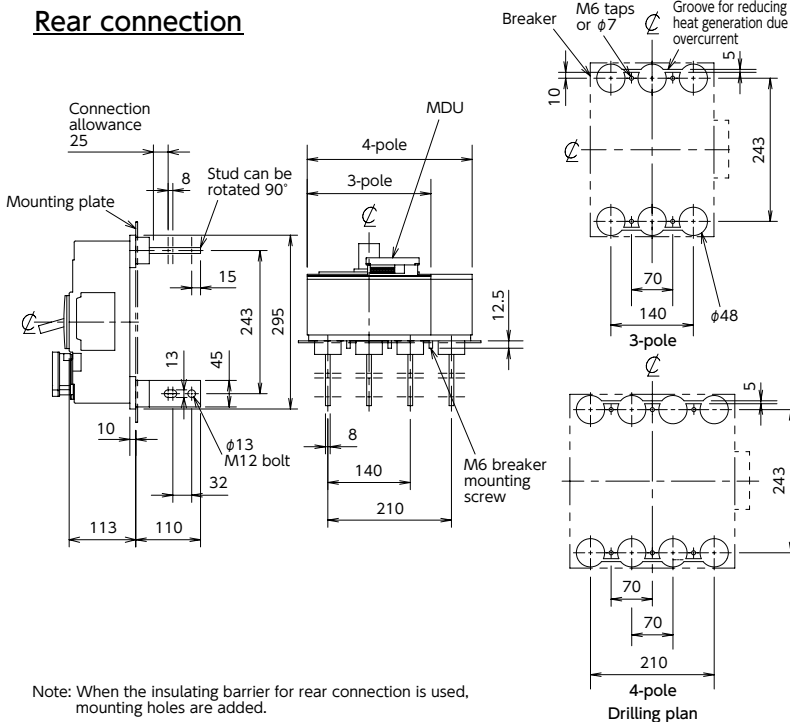

Note: When the insulating barrier for rear connection is used, mounting holes are added.

Front-panel cutout

The dimensions include a clearance of 1.0 mm on each side of the breaker frame. (A gap for passing the electric wires to the terminal block is provided on the load side in the case of mounting on breaker.)

When the breaker is provided with the CC-Link communication (MDU-BC) or MODBUS communication (MDU-BM), the cutout for mounting on breaker cannot be made in the front plate.

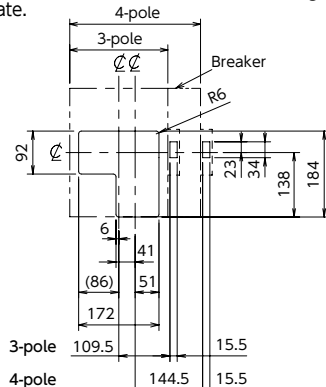

Internal accessories (option)

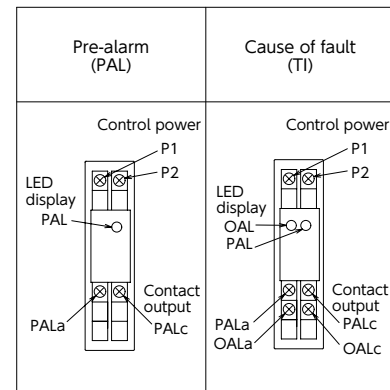

MDU terminal

In the figure below the terminal cover is removed. Secure the wires with cable clamps, etc.

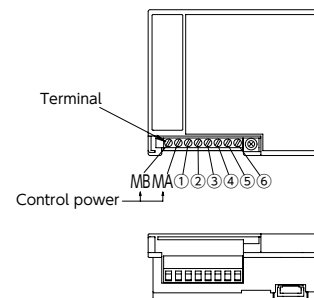

Model	Spec.	①	②	③	④	⑤	⑥
MDU-BN	No transmission	—	FG	—	—	—	—
MDU-BP	Pulse output	—	FG	—	—	Cb	Ca
MDU-BC	CC-Link	—	FG	SLD	DG	DB	DA
MDU-BM	MODBUS	—	FG	SLD	485+	485-	Ter

Outline dimensional drawings

NF800-SEW with MDU Panel mounting
 NF800-HEW with MDU Panel mounting

Front connection

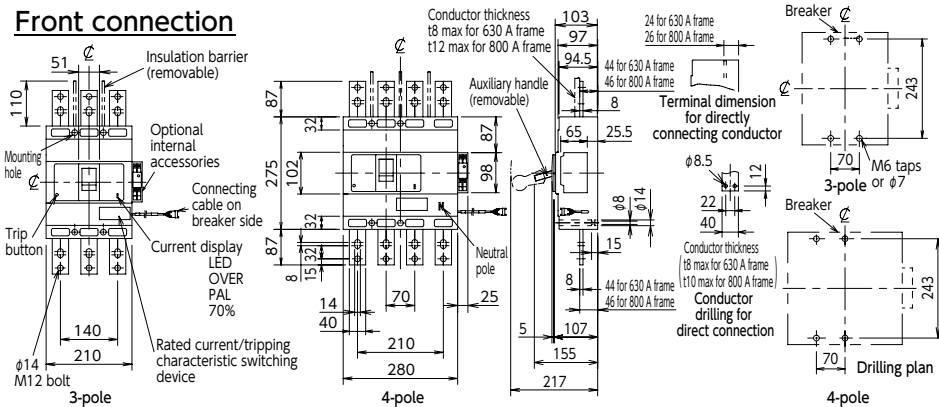

Front-panel cutout

1.0 mm clearance on each side of the handle frame

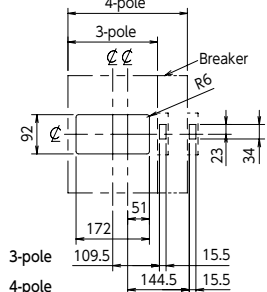

Rear connection

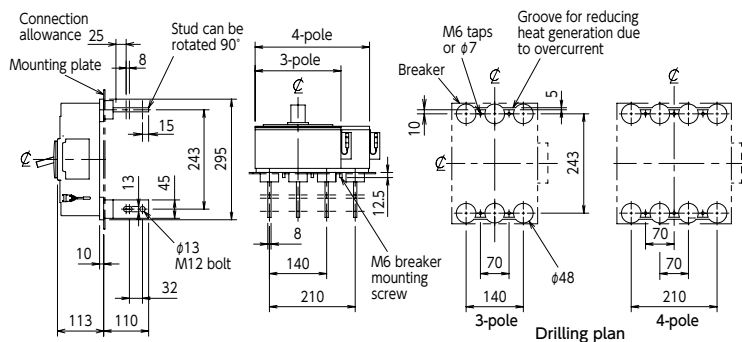

Internal accessories (option)

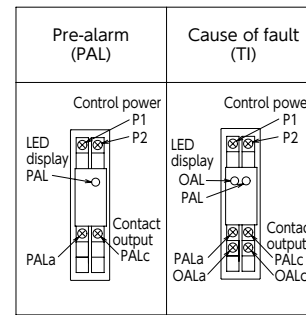

Note: When the insulating barrier for rear connection is used, mounting holes are added.

Mounting on MDU panel

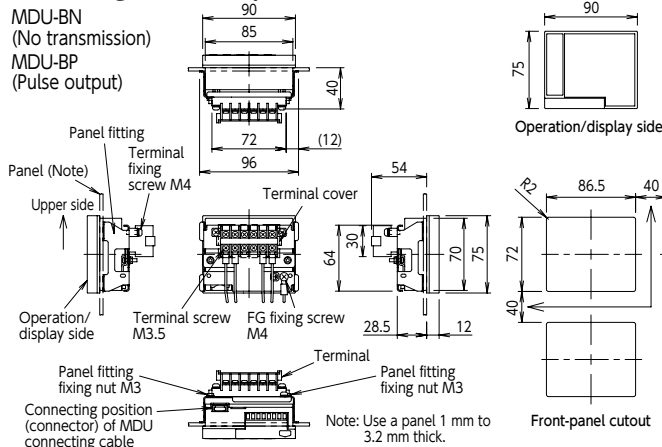

When installing, ensure a distance larger than the following size, and keep a space of 10 cm or more from the distribution line.

MDU terminal arrangement

Secure the wires with cable clamps, etc.

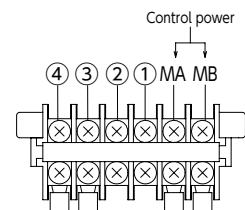
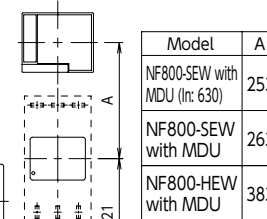

Model	A
NF800-SEW with MDU (In: 630)	253
NF800-SEW with MDU	263
NF800-HEW with MDU	383

MDU model	Spec.	①	②	③	④
MDU-BN	No transmission	—	—	—	—
MDU-BP	Pulse output	—	—	Ca	Ca

Mounting on MDU panel

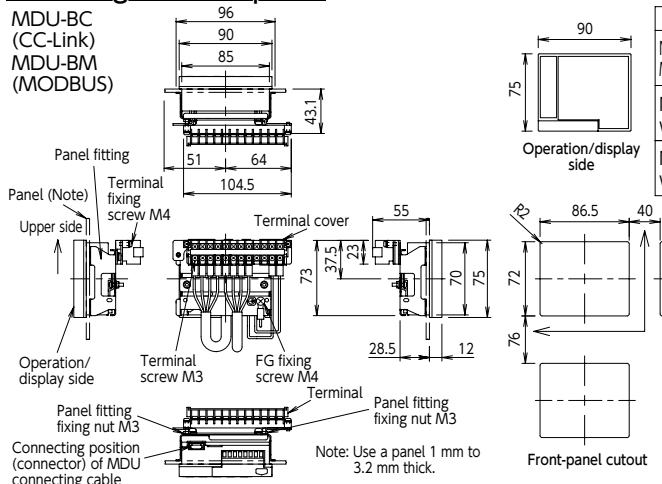

When installing, ensure a distance larger than the following size, and keep a space of 10 cm or more from the distribution line.

MDU terminal arrangement

Secure the wires with cable clamps, etc.

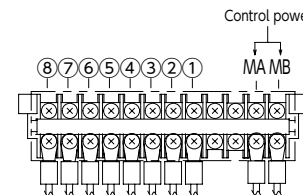
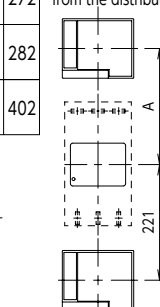

Model	A
NF800-SEW with MDU (In: 630)	272
NF800-SEW with MDU	282
NF800-HEW with MDU	402

MDU model	Spec.	①	②	③	④	⑤	⑥	⑦	⑧
MDU-BC	CC-Link	SLD	DG	DB	DA	SLD	DG	DB	DA
MDU-BM	MODBUS	SLD	485+	485+	Ter	SLD	485+	485+	Ter

Note: In the case of front connection, keep a sufficient distance from the connecting wires and insulating barrier.

Outline dimensional drawings

NF800-SEW with MDU Breaker mounting
 NF800-HEW with MDU Breaker mounting

Front connection

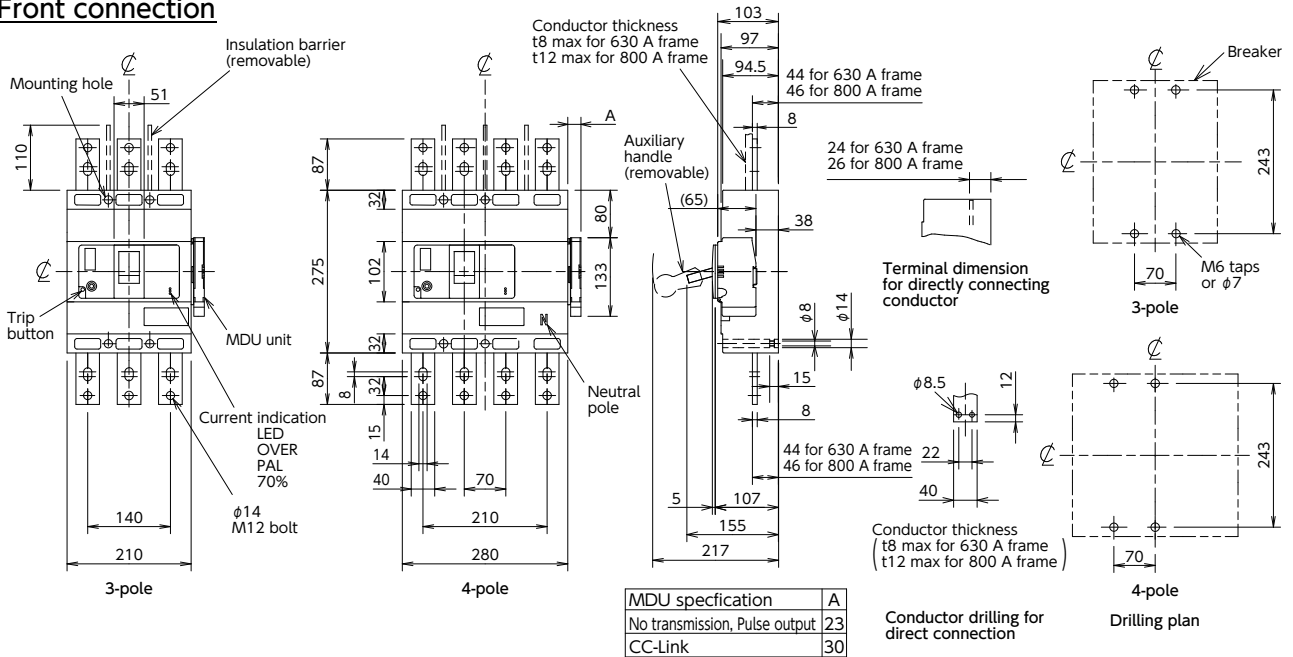

Rear connection

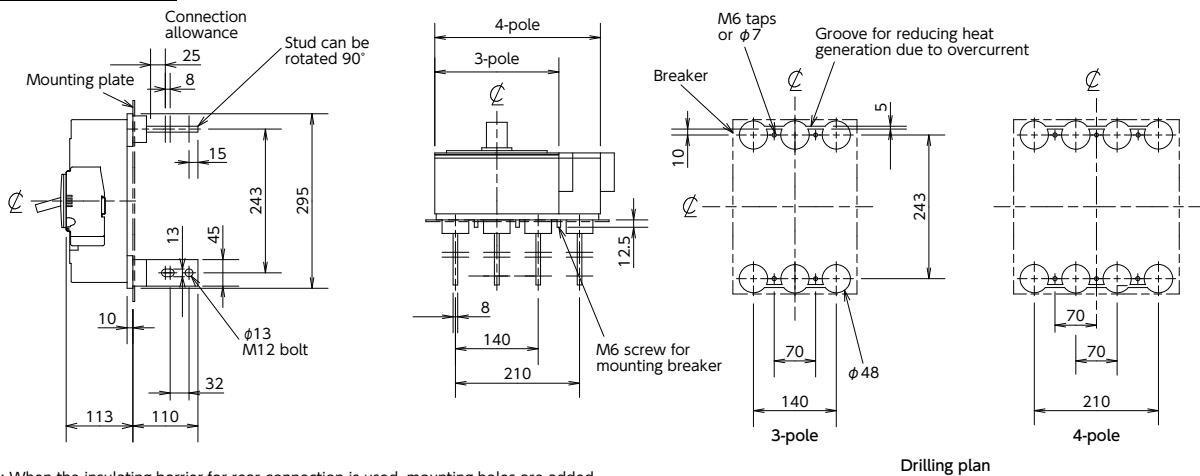

Note: When the insulating barrier for rear connection is used, mounting holes are added.

Front-panel cutout

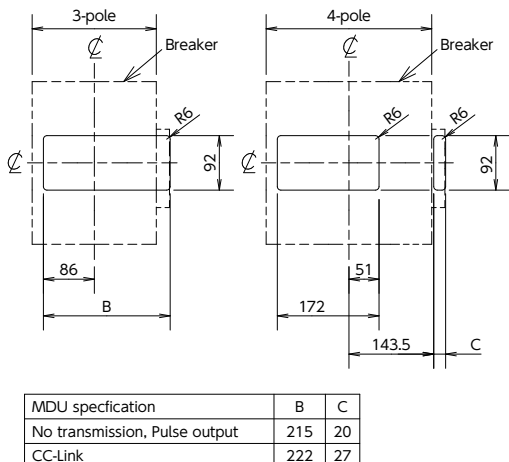

MDU unit outline

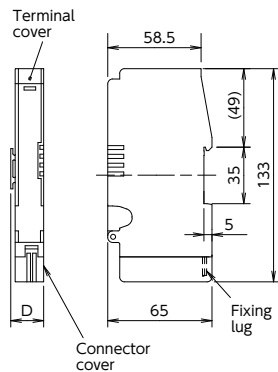

MDU unit terminal

The figure is without terminal cover and connector cover. Please fix the wiring with clamp etc.

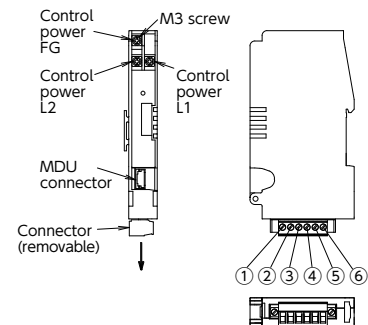

How to order MDU Breaker

How to order breaker integrated with measuring display unit (MDU) (1)

The items in the shaded rows are required in any case. Specify them without fail. If any other items are not specified, we will manufacture the product according to our standard specifications.

		Molded-case Circuit Breaker	
Breaker body	Type name	<input type="checkbox"/> NF250-SEV with MDU <input type="checkbox"/> NF250-HEV with MDU	
	Number of poles	<input type="checkbox"/> 3P <input type="checkbox"/> 4P	
	Installation and connections	<input type="checkbox"/> Front connection (F), <input type="checkbox"/> Rear connection (B)	
Internal accessories	<input type="checkbox"/> Alarm switch (AL) ————— <input type="checkbox"/> With lead-wire terminal block (SLT) — Quantity (left pole <input type="checkbox"/> 1 pc.) <input type="checkbox"/> For minute electric current (right pole <input type="checkbox"/> 1 pc.) Only NF250-SEV/HEV		
	<input type="checkbox"/> Auxiliary switch (AX) ————— <input type="checkbox"/> With lead-wire terminal block (SLT) — Quantity (left pole <input type="checkbox"/> 1 pc. <input type="checkbox"/> 2 pcs.) <input type="checkbox"/> For minute electric current (right pole <input type="checkbox"/> 1 pc.) Only NF250-SEV/HEV		
Alarm contact output (*2) (*3)	Pre-alarm (PAL)	<input type="checkbox"/> PAL (option)	
	<input type="checkbox"/> Undervoltage trip (UVT) ————— <input type="checkbox"/> Select 100-130 V AC/100-130 V DC <input type="checkbox"/> Voltage module mounted on side <input type="checkbox"/> Reset prevention type <input type="checkbox"/> 200-250 V AC <input type="checkbox"/> Voltage module mounted separately <input type="checkbox"/> Reset permission type <input type="checkbox"/> 380-480 V AC		
MDU	Mounting (*1) (*3) (*9)	<input type="checkbox"/> External mounting <input type="checkbox"/> Panel mounting (with standard cable 2 m long, <input type="checkbox"/> 0.5 m, <input type="checkbox"/> 3 m, <input type="checkbox"/> 5 m, <input type="checkbox"/> 10 m selectable) <input type="checkbox"/> Breaker mounting <input type="checkbox"/> Breaker mounting unit separate installation (with standard cable 2 m long, <input type="checkbox"/> 0.5 m, <input type="checkbox"/> 3 m, <input type="checkbox"/> 5 m, <input type="checkbox"/> 10 m selectable)	
	Transmission system	<input type="checkbox"/> No transmission (standard) <input type="checkbox"/> Electric energy pulse output <input type="checkbox"/> MODBUS <input type="checkbox"/> CC-Link communication (any one)	
External accessories	When mounted on breaker body	<input type="checkbox"/> Handle lock device (<input type="checkbox"/> HL <input type="checkbox"/> HL-S) <input type="checkbox"/> Card folder <input type="checkbox"/> LC	<input type="checkbox"/> Terminal cover ————— (*7) <input type="checkbox"/> TC-S <input type="checkbox"/> TC-L (*5) <input type="checkbox"/> TC-LL (*6) <input type="checkbox"/> TTC (*5) <input type="checkbox"/> BTC
	When mounted on panel	<input type="checkbox"/> Handle lock device (<input type="checkbox"/> HL <input type="checkbox"/> HL-S) <input type="checkbox"/> Mechanical interlock (MI) (Only 3-pole type) <input type="checkbox"/> Card folder CH <input type="checkbox"/> LC <input type="checkbox"/> F type operating handle <input type="checkbox"/> S type operating handle <input type="checkbox"/> V type operating handle	<input type="checkbox"/> Electrical operation device <input type="checkbox"/> Terminal cover ————— (*8) <input type="checkbox"/> TC-S <input type="checkbox"/> TC-L (*5) <input type="checkbox"/> TC-LL (*6) <input type="checkbox"/> TTC (*5) <input type="checkbox"/> BTC
	When built-in display is used When built-in display unit is separately mounted	<input type="checkbox"/> Handle lock device HL <input type="checkbox"/> Card folder CH <input type="checkbox"/> LC	<input type="checkbox"/> Terminal cover ————— (*4) <input type="checkbox"/> TC-S <input type="checkbox"/> TC-L (*5) <input type="checkbox"/> TC-LL (*6) <input type="checkbox"/> TTC (*5) <input type="checkbox"/> BTC

Notes: *1 When changing the mounting method after the product is delivered, consult us.
 *2 The LCD, transmission and contact output of the PAL function are enabled when the breaker is provided with the PAL module (option).

Alarm	LCD	Transmission	Contact output
PAL	Option	Option	Option

- The alarm (PAL) mode can be switched between self-holding and automatic reset.
- *3 When the right pole SLT or PAL is specified as an internal accessory, the MDU mounting method is "separate mounting of built-in display unit," "mounting on panel" or "mounting on breaker."
 - *4 When the "MDU built-in display" or "PAL" is selected, the dedicated terminal cover is used. Specify MP at the end of the model name. (Example: TC2-2SV3MP) (In the case of "separate mounting of MDU built-in display unit," the standard terminal cover is used.)
 - *5 When the solderless terminal 2CR-150 or CB150-S8 (wire of 117.2 to 152.05 mm²) is used, TC-L and TTC cannot be installed. Insulate from TC-S with insulating tube or tape. In the case of a 3-pole breaker, TC-LL can be used.
 - *6 The solderless terminals 2CR-150 and CB150-S8 (wire of 117.2 to 152.05 mm²) can be used.
 - *7 Cover dedicated for MDU
 - *8 When the breaker is provided with the alarm contact output (PAL module), the dedicated terminal cover is used.
 - *9 For MODBUS, the unit is mounted on the breaker body or panel.

How to order MDU Breaker

● How to order breaker integrated with measuring display unit (MDU) (2)

The items in the shaded rows are required in any case. Specify them without fail. If any other items are not specified, we will manufacture the product according to our standard specifications.

		Molded-case Circuit Breaker	
Breaker body	Type name	<input type="checkbox"/> NF400-SEW with MDU <input type="checkbox"/> NF400-HEW with MDU	<input type="checkbox"/> NF800-SEW with MDU <input type="checkbox"/> NF800-HEW with MDU
	Number of poles	<input type="checkbox"/> 3P <input type="checkbox"/> 4P	
	Installation and connections	<input type="checkbox"/> Front connection (F), <input type="checkbox"/> Rear connection (B)	
Internal accessories	<input type="checkbox"/> Alarm switch (AL) ————— <input type="checkbox"/> With lead-wire terminal block (SLT) — Quantity (left pole <input type="checkbox"/> 1 pc. <input type="checkbox"/> 2 pcs. <input type="checkbox"/> 3 pcs.) <input type="checkbox"/> For minute electric current <input type="checkbox"/> Auxiliary switch (AX) ————— <input type="checkbox"/> With lead-wire terminal block (SLT) — Quantity (left pole <input type="checkbox"/> 1 pc. <input type="checkbox"/> 2 pcs. <input type="checkbox"/> 3 pcs.) <input type="checkbox"/> For minute electric current (right pole <input type="checkbox"/> 1 pc. <input type="checkbox"/> 2 pcs.) <input type="checkbox"/> Alarm switch for MDU transmission ————— <input type="checkbox"/> AL-4N <input type="checkbox"/> Auxiliary switch for MDU transmission ————— <input type="checkbox"/> AX-4N <input type="checkbox"/> Alarm/auxiliary switch for MDU transmission — <input type="checkbox"/> ALAX-4N <input type="checkbox"/> Shunt trip (SHT) ————— <input type="checkbox"/> 100-450 V AC/100-200 V DC common — <input type="checkbox"/> With lead-wire terminal block (SLT) <input type="checkbox"/> Undervoltage trip (UVT) <input type="checkbox"/> Reset prevention type (*1) ————— <input type="checkbox"/> Select 100-110/120-130 V AC ————— <input type="checkbox"/> Voltage module mounted on side <input type="checkbox"/> Select 200-220/230-250 V AC ————— <input type="checkbox"/> Voltage module mounted separately <input type="checkbox"/> Select 380-415/440-480 V AC <input type="checkbox"/> Select 100/110 V DC		
	Alarm contact output (*3) Pre-alarm (PAL)	<input type="checkbox"/> PAL (option) <input type="checkbox"/> TI (option)	
MDU	Mounting (*4) (*5) (*10)	<input type="checkbox"/> External mounting <input type="checkbox"/> Panel mounting (with standard cable 2 m long, <input type="checkbox"/> 0.5 m, <input type="checkbox"/> 3 m, <input type="checkbox"/> 5 m, <input type="checkbox"/> 10 m selectable) <input type="checkbox"/> Breaker mounting <input type="checkbox"/> Breaker mounting unit separate installation (with standard cable 2 m long, <input type="checkbox"/> 0.5 m, <input type="checkbox"/> 3 m, <input type="checkbox"/> 5 m, <input type="checkbox"/> 10 m selectable)	
	Transmission system	<input type="checkbox"/> No transmission (standard) <input type="checkbox"/> Electric energy pulse output <input type="checkbox"/> MODBUS <input type="checkbox"/> CC-Link communication (any one)	
External accessories	When mounted on breaker body	<input type="checkbox"/> Handle lock device (HL) <input type="checkbox"/> Auxiliary handle (HT) (*6) <input type="checkbox"/> Terminal cover ————— <input type="checkbox"/> TTC (dedicated for MDU) <input type="checkbox"/> BTC (mountable only on power supply side) (*9)	
	When mounted on panel	<input type="checkbox"/> Handle lock device (<input type="checkbox"/> HL <input type="checkbox"/> HL-S) <input type="checkbox"/> Electrical operation device (*7) <input type="checkbox"/> Mechanical interlock (MI) <input type="checkbox"/> Terminal cover ————— <input type="checkbox"/> TTC <input type="checkbox"/> Auxiliary handle (HT) (*6) <input type="checkbox"/> TC-L (*8) <input type="checkbox"/> F type operating handle <input type="checkbox"/> BTC (*9) <input type="checkbox"/> S type operating handle <input type="checkbox"/> V type operating handle	
	When built-in display is used When built-in display unit is separately mounted	<input type="checkbox"/> Handle lock device (HL) <input type="checkbox"/> Auxiliary handle (HT) (*6) <input type="checkbox"/> Terminal cover ————— <input type="checkbox"/> TTC <input type="checkbox"/> TC-L (*8) <input type="checkbox"/> BTC (*9)	

- Notes: *1 Specify the reset prevention type if necessary. If the type is not specified, the reset permission type will be installed.
 *2 Specify 24 V DC if necessary. If the voltage is not specified, the device common to 100 to 240 V AC/DC will be installed.
 *3 The display and transmission of the breaker alarms, PAL, OVER and OAL, on the MDU are included as standard. Only when the contact output is required, specify the alarm contact output.
 The contact output of the cause of fault (OAL) is self-holding type. The alarm (PAL) can be switched between "self-holding" and "automatic reset."

Alarm	LCD	Transmission	Contact output
PAL	Standard	Standard	Option

- *4 When changing the mounting method after the product is delivered, consult us.
 *5 The accessory can be mounted on the right pole in the case of "separate mounting of built-in display unit," "mounting on panel" or "mounting on breaker."
 *6 The handle is included as standard in 800 A frame 4-pole breakers.
 *7 The device can be manufactured only in the case of mounting on panel. It cannot be manufactured for a Molded-case Circuit Breaker provided with the alarm contact output for PAL or TI.
 *8 TC-L cannot be used on NF400-HEW or NV400-HEW.
 *9 PTC for 3-pole NF400-HEW and NV400-HEW
 *10 For MODBUS, the unit is mounted on the breaker body or panel.

MEMO

A series of horizontal dotted lines for writing.

MDU BREAKER

For Safety : Please read the instruction manual carefully before using the products in this catalog.
Wiring and connection must be done by the person who has specialized knowledge of electric construction and wirings.



for a greener tomorrow

Eco Changes is the Mitsubishi Electric Group's environmental statement, and expresses the Group's stance on environmental management. Through a wide range of businesses, we are helping contribute to the realization of a sustainable society.

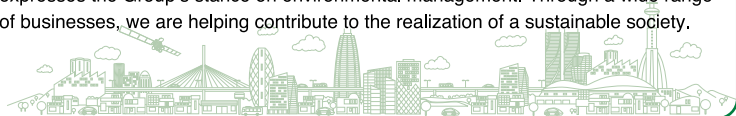

MITSUBISHI ELECTRIC CORPORATION

HEAD OFFICE: TOKYO BUILDING, 2-7-3, MARUNOUCHI, CHIYODA-KU, TOKYO 100-8310, JAPAN