

Power Factor Meters

For balanced circuits

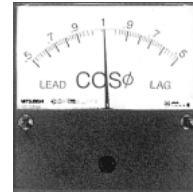

YP-12NPF



LP-110NPF

Specifications

		Rectangular indicators																															
		Y-2N Series								Y-N Series																							
Size (width × height)	mm	64×60				85×75				100×85				82×82				102×102															
Model name		YP-206NPF				YP-208NPF				YP-210NPF				YP-8NPF				YP-10NPF															
Operation principle		Transducer																															
Accuracy (grade)		5																															
Scale		LEAD 0.5~1~0.5 LAG																															
Frequency		50 and 60Hz																															
Scale length (mm)		55				70				85				70				90															
Weight (kg)		0.07				0.1				0.1				0.2				0.2															
Indicator rating and delivery period classification	Circuit	Rating	Consumption VA		Accessory	Delivery period classification	Consumption VA		Accessory	Delivery period classification	Consumption VA		Accessory	Delivery period classification	Consumption VA		Accessory	Delivery period classification	Consumption VA		Accessory	Delivery period classification											
			Voltage circuit	Current circuit			Voltage circuit	Current circuit			Voltage circuit	Current circuit			Voltage circuit	Current circuit			Voltage circuit	Current circuit													
	3-phase 3-wire balanced circuit	110V 5A	1	1	T-100	○	1	1	T-100	○	1	1	T-100	○	1	1	—	○	1	1	—	○											
		220V 5A	2	1	T-100	○	2	1	T-100	○	2	1	T-100	○	2	1	—	○	2	1	—	○											
Page with outer dimensions drawing		35																36															

		Rectangular indicators						Wide-angle indicators										
		Y-N Series						L-N Series										
Size (width × height)	mm	122×122						80×80				110×110						
Model name		YP-12NPF						LP-80NPF				LP-110NPF						
Operation principle		Transducer																
Accuracy (grade)		5																
Scale		LEAD 0.5~1~0.5 LAG																
Frequency		1-phase 2-wire: specify 50Hz or 60Hz 3-phase 3-wire: 50 and 60Hz						1-phase 2-wire: specify 50Hz or 60Hz 3-phase 3-wire: 50 and 60Hz										
Scale length (mm)		100						124				175						
Weight (kg)		0.4						0.4				0.5						
Indicator rating and delivery period classification	Circuit	Rating	Consumption VA		Accessory	Delivery period classification	Consumption VA		Accessory	Delivery period classification	Consumption VA		Accessory	Delivery period classification	Consumption VA		Accessory	Delivery period classification
			Voltage circuit	Current circuit			Voltage circuit	Current circuit			Voltage circuit	Current circuit			Voltage circuit	Current circuit		
	1-phase 2-wire	110V 5A	1.3	0.5	—	△	—								1.3	0.5	—	△
		220V 5A	2.6	0.5	—	△	—								2.6	0.5	—	△
3-phase 3-wire balanced circuit	110V 5A	1	1	—	◎	1	1	—	○	1	1	—	○	1	1	—	◎	
	220V 5A	2	1	—	○	2	1	—	○	2	1	—	○	2	1	—	○	
Page with outer dimensions drawing		36						37										

- Remarks**
- Indicators with a LEAD 0–1–0 LAG scale can also be manufactured; however, measured values for power factors of 0.5 or less are for reference only.
 - Use with an input current of 1/5 (e.g. 1A) or more of the rated current (e.g. 5A). The error increases as the input current decreases.
 - In a power OFF or no-load state, the pointer of the power factor meter stops at the mechanical zero point; black point near the power factor of 1.
 - The T-100 rectifier is a dedicated accessory (non-compatible accessory), and thus cannot be used in combinations other than those designated for the indicators.
 - Models with a current rating of 1A can also be manufactured; the power consumption is basically the same as that of a 5A model.
 - Four-quadrant power factor meters can also be manufactured for LI-1NPF 3-phase, 3-wire balanced circuits. Please contact a Mitsubishi Electric representative for details.
 - The weight of the T-100 rectifier is approximately 0.9kg.
 - Cannot use with unbalanced loads.
 - Please specify the frequency in the case of the power factor meter for 1-phase, 2-wire systems.
 - Use with a positive phase sequence.
 - In the case of a negative phase sequence input with a 3-phase, 3-wire circuit, LEAD and LAG are indicated in an inverted manner. Indicators return to normal operation when the connections of the P2 and P3 circuits of the voltage input terminals are interchanged.
 - Please make sure to read the "Safety Precautions" (pp.5-8) and the "Selection Precautions" (p.9) to assist in selecting the model and use specifications suited to the application.

Delivery period classification

Symbol	◎Standard product	○Quasi-standard product	△Special product
Reference delivery period	Immediate delivery	Within 20 days	21 to 60 days

Ordering method

The items in must be specified.

Model name	Phase-wire system	Indicator rating	Scale	Cover type	Frequency	Special specifications	Number of units
YP-12NPF	3P3W	110V 5A	LEAD0.5-1-0.5LAG	B	50Hz	Colored lines, colored bands, etc.	3

Specify in the case of a 1-phase, 2-wire system.

Outer dimensions of accessory

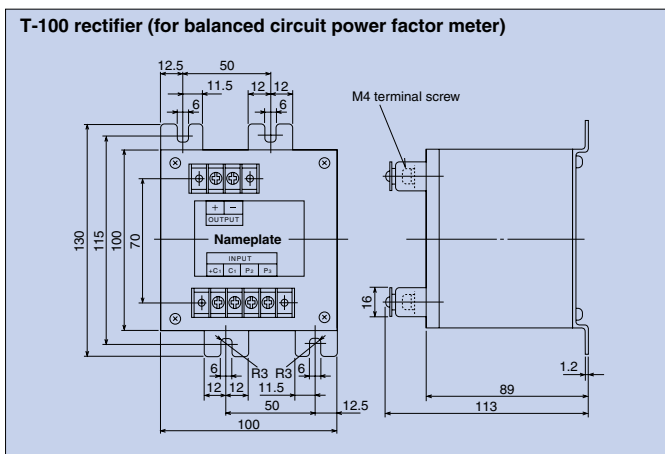

Connection diagrams

1-phase, 2-wire systems

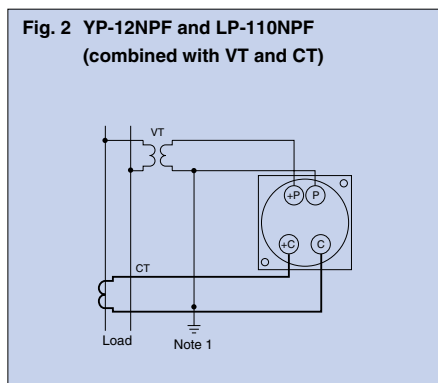
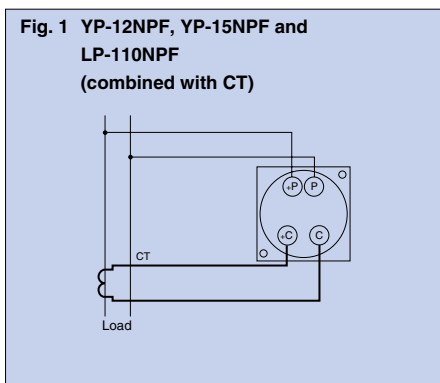

3-phase, 3-wire systems

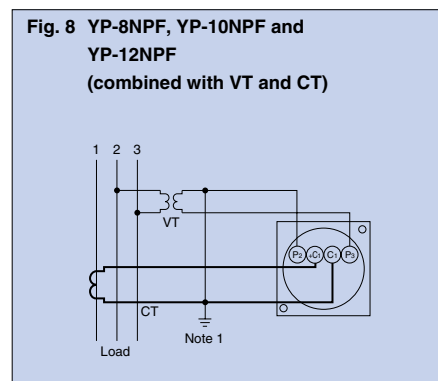
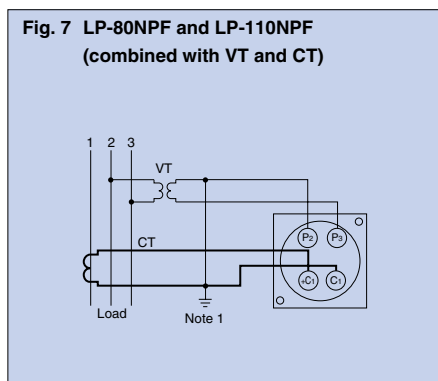
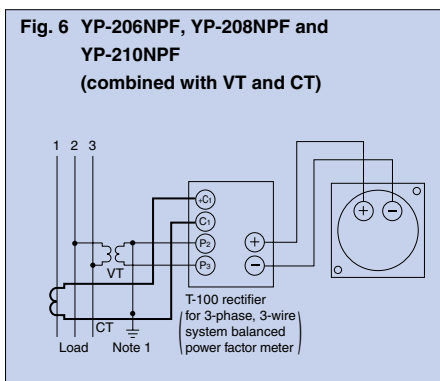
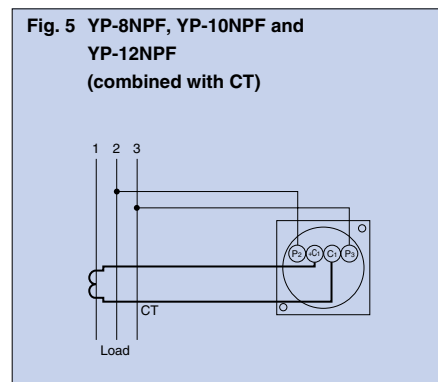
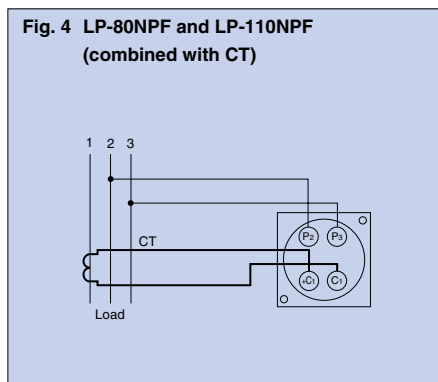
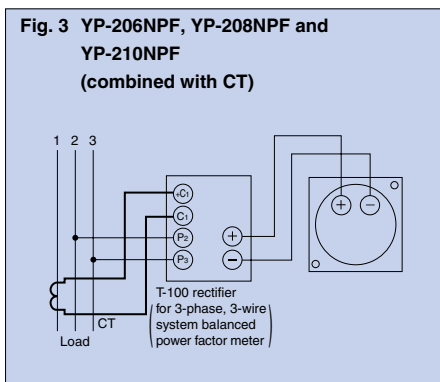

Note 1. For low-voltage circuits, grounding of the secondary sides of the instrument voltage transformer and current transformer is unnecessary.

Power Factor Meters

For unbalanced loads



YP-208NPFU



YP-10NPFU

Specifications

		Rectangular indicators																					
		Y-2N Series									Y-N Series												
Size (width X height)	mm	64X60			85X75			100X85			82X82			102X102									
Model name		YP-206NPFU			YP-208NPFU			YP-210NPFU			YP-8NPFU			YP-10NPFU									
Operation principle		Transducer									Transducer												
Accuracy (grade)		5									5												
Scale		LEAD 0.5~1~0.5 LAG									LEAD 0.5~1~0.5 LAG												
Frequency		50 or 60Hz									50 or 60Hz												
Scale length (mm)		55			70			85			70			90									
Weight (kg)		0.07			0.1			0.1			0.1			0.15									
Indicator rating and delivery period classification	Circuit	Rating	Consumption VA		Accessory	Delivery period classification	Consumption VA		Accessory	Delivery period classification	Consumption VA		Accessory	Delivery period classification	Consumption VA		Accessory	Delivery period classification	Consumption VA		Accessory	Delivery period classification	
			Voltage circuit	Current circuit			Voltage circuit	Current circuit			Voltage circuit	Current circuit			Voltage circuit	Current circuit			Voltage circuit	Current circuit			
	3-phase unbalanced loads	3-phase 3-wire	110V 5A	1	2	T-150	○	1	2	T-150	○	1	2	T-150	○	1	2	T-150	○	1	2	T-150	○
		220V 5A	2	2	T-150	○	2	2	T-150	○	2	2	T-150	○	2	2	T-150	○	2	2	T-150	○	
		3-phase 4-wire	$\frac{110}{\sqrt{3}}$ /110V 5A	0.7	1	2	T-150	○	0.7	1	2	T-150	○	0.7	1	2	T-150	○	0.7	1	2	T-150	○
110/190V 5A	1	1	2	T-150	○	1	1	2	T-150	○	1	1	2	T-150	○	1	1	2	T-150	○			
Page with outer dimensions drawing		35									36												

- Remarks**
- (1) A LEAD 0~1~0 LAG scale can also be manufactured; however, the measured power factor values of 0.5 or less are for reference only.
 - (2) Please specify the frequency.
 - (3) Use with an input current of 1/5 (e.g. 1A) or more of the rated current (e.g. 5A). The error increases as the input current decreases.
 - (4) In the power off or no-load state, the needle of the power factor meter stops at the mechanical zero point; black point near the power factor of 1.
 - (5) The T-150 rectifier is a dedicated accessory (non-compatible accessory), and thus cannot be used in combinations other than those designated for the indicators. The distance between the indicator and the T-150 rectifier must be 5m or less, or the round-trip lead wire resistance must be 0.5Ω or less.
 - (6) Models with a current rating of 1A can also be manufactured; the power consumption is basically the same as that of a 5A model.
 - (7) The weight of the T-150 rectifier is approximately 1.4kg.
 - (8) Can also be used for balanced circuits.
 - (9) Use with a positive phase sequence.
For the following models, indicators will not function normally when a negative-phase sequence is input. Return the indicators to normal operation by interchanging the voltage and current circuits.

Model name	Indication state	Reset indicator for normal operation
YP-206NPFU, YP-208NPFU YP-210NPFU YP-8NPFU, YP-10NPFU LP-80NPFU	The indicator reading is unclear.	Change the voltage and current circuit connections as follows: • Switch P1 and P3 • Switch +C1 and +C3 • Switch C1 and C3

- (10) Please make sure to read the "Safety Precautions" (pp.5-8) and the "Selection Precautions" (p.9) to assist in selecting the model and use specifications suited to the application.

Ordering method

The items in must be specified.

Model name	Phase-wire system	Indicator rating	Scale	Cover type	Frequency	Special specifications	Number of units
YP-12NPFU	3P3W	110V 5A	LEAD0.5-1-0.5LAG	B	50Hz	Colored lines, colored bands, etc.	3

Power Factor Meters

Connection diagrams

3-phase, 3-wire systems (unbalanced loads)

Fig. 1 YP-206NPFU, YP-208NPFU, YP-210NPFU, YP-8NPFU, YP-10NPFU and LP-80NPFU (combined with CT)

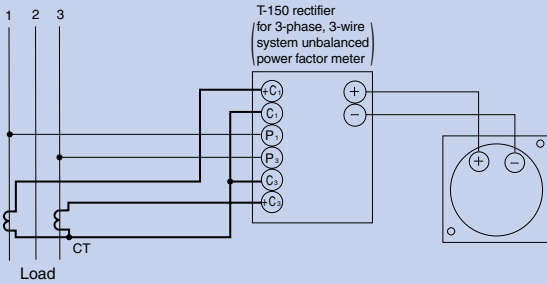

Fig. 2 YP-206NPFU, YP-208NPFU, YP-210NPFU, YP-8NPFU, YP-10NPFU and LP-80NPFU (combined with VT and CT)

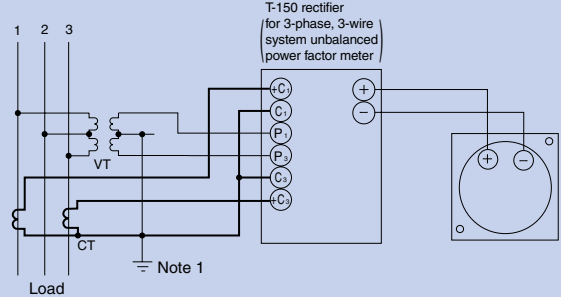

Fig. 3 YP-12NPFU and LP-110NPFU (combined with CT)

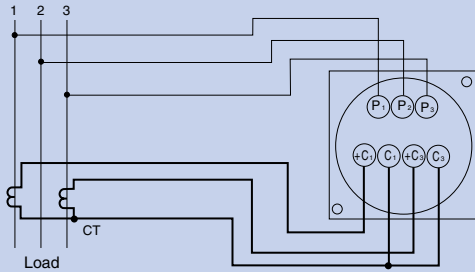
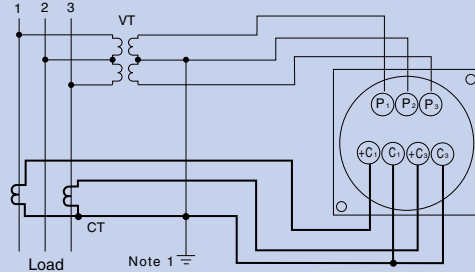

Fig. 4 YP-12NPFU and LP-110NPFU (combined with VT and CT)



3-phase, 4-wire systems

Fig. 5 YP-206NPFU, YP-208NPFU, YP-210NPFU, YP-8NPFU, YP-10NPFU and LP-80NPFU (combined with CT)

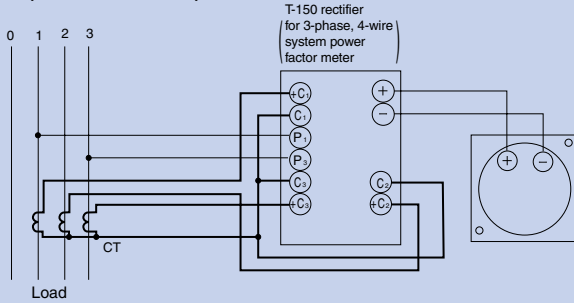

Fig. 6 YP-206NPFU, YP-208NPFU, YP-210NPFU, YP-8NPFU, YP-10NPFU and LP-80NPFU (combined with VT and CT)

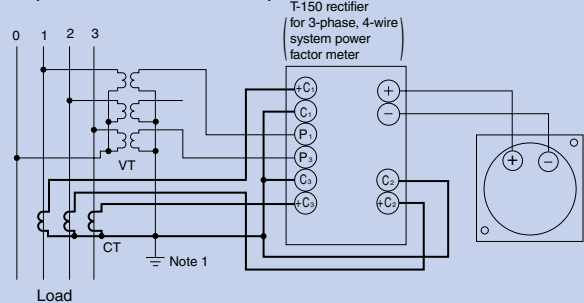

Fig. 7 YP-12NPFU and LP-110NPFU (combined with CT)

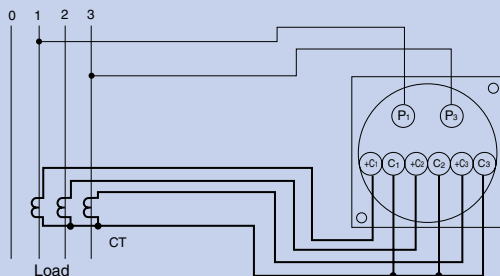
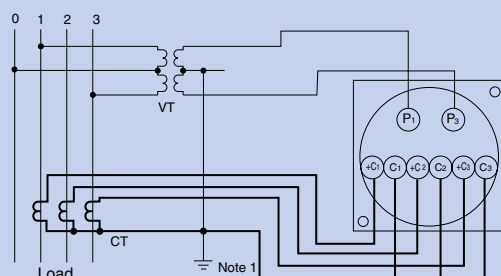
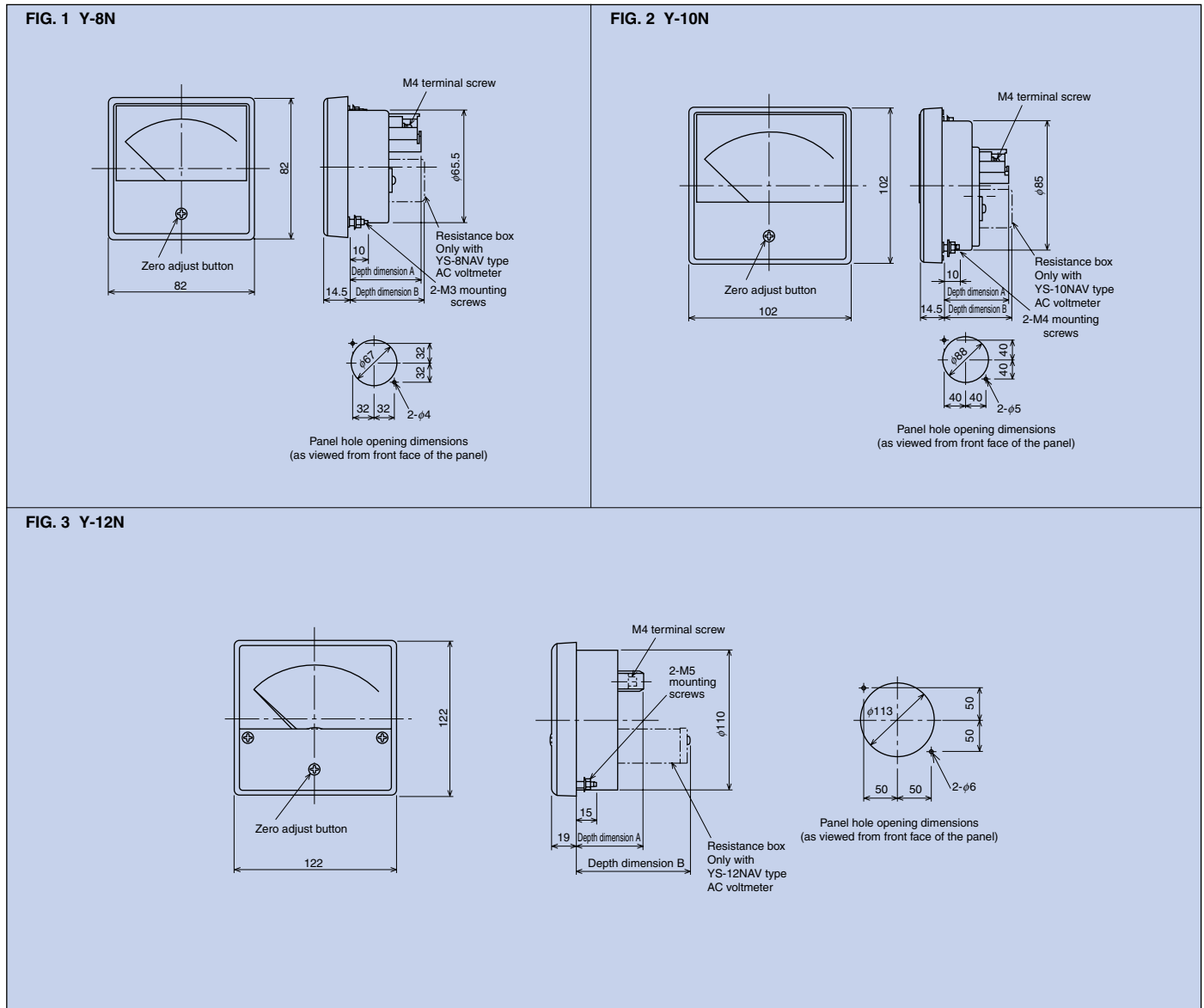

Fig. 8 YP-12NPFU and LP-110NPFU (combined with VT and CT)



Note 1. For low-voltage circuits, grounding of the secondary sides of the instrument voltage transformer and current transformer is unnecessary.

Rectangular indicators (Y-N Series)



● Depth dimension details

Indicator type		Y-8N			Y-10N			Y-12N			
		Type name	A dimension	B dimension	Type name	A dimension	B dimension	Type name	A dimension	B dimension	
DC	Ammeters	YM-8NDA	41	—	YM-10NDA	41	—	YM-12NDA	50	—	
	Voltmeters	YM-8NDV	41	—	YM-10NDV	41	—	YM-12NDV	50	—	
AC	Ammeters	YS-8NAA	41	—	YS-10NAA	41	—	YS-12NAA	50	—	
		Uniform scale	YR-8NAA	41	—	YR-10NAA	41	—	YR-12NAA	50	—
	Voltmeters	YS-8NAV	41	43	YS-10NAV	41	43	YS-12NAV	50	85	
		Uniform scale	YR-8NAV	41	—	YR-10NAV	41	—	YR-12NAV	50	—
	Wattmeters	YP-8NW	41	—	YP-10NW	41	—	YP-12NW	100	—	
	Varmeters	YP-8NVAR	41	—	YP-10NVAR	41	—	YP-12NVAR	100	—	
	Power-factor meters	Balanced	YP-8NPF	81	—	YP-10NPF	81	—	YP-12NPF	50	Note
		Unbalanced	YP-8NPFU	41	—	YP-10NPFU	41	—	YP-12NPFU	100	—
Frequency meters	YP-8NF	81	—	YP-10NF	81	—	YP-12NF	50	—		
Receiving indicators	DC indicators	YM-8NRI	41	—	YM-10NRI	41	—	YM-12NRI	50	—	
	AC indicators	YR-8NRI	41	—	YR-10NRI	41	—	YR-12NRI	50	—	

Note. 100mm in the case of a model for 1-phase 2-wire systems.



Outer Dimension Drawings

(Refer to the specification tables regarding models other than the Y-2N series, Y-N series, and L-N series.)

Mechanical Indicators

Rectangular indicators (Y-2N Series)

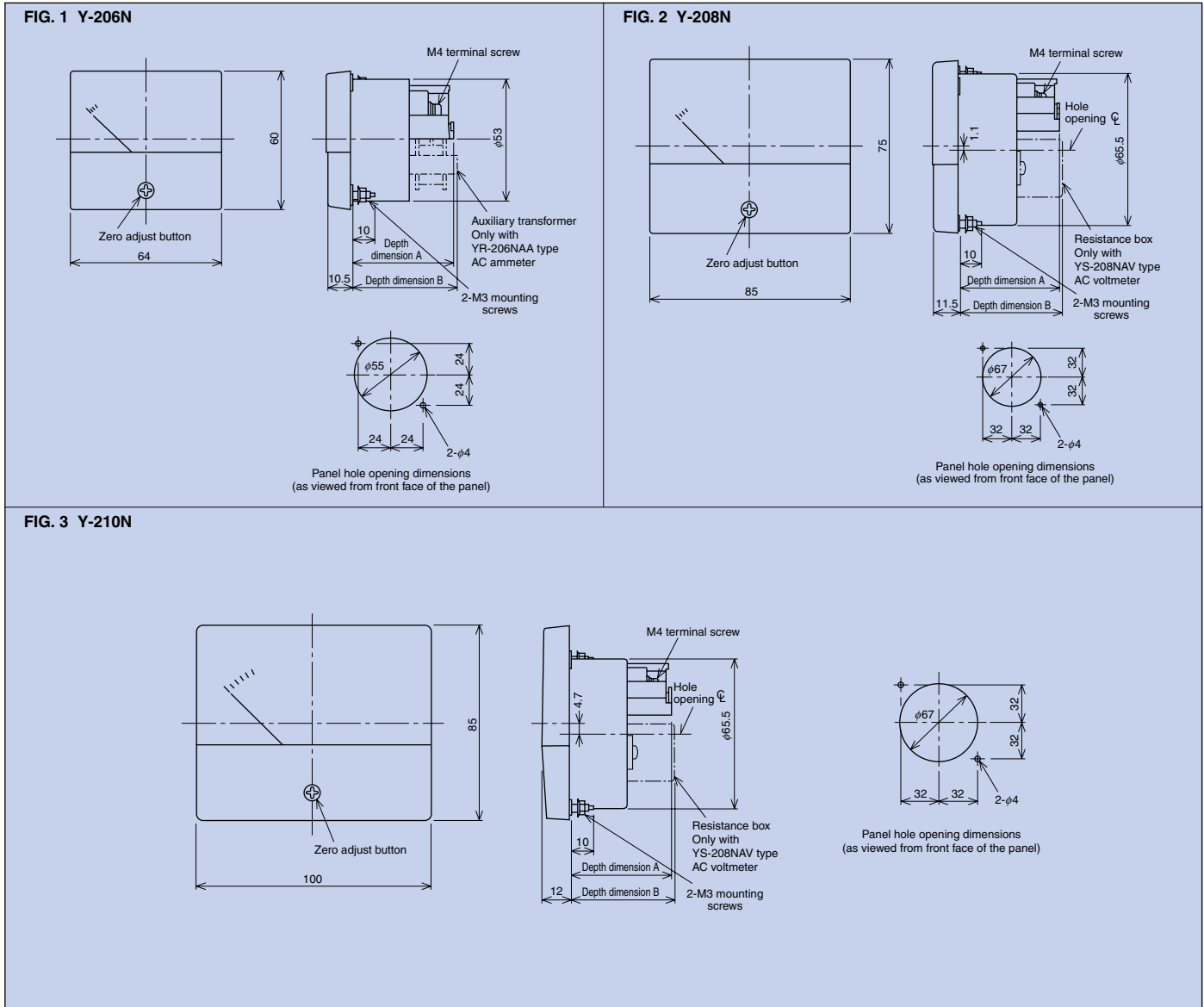

● Depth dimension details

Indicator type		Y-206N			Y-208N			Y-210N		
		Type name	A dimension	B dimension	Type name	A dimension	B dimension	Type name	A dimension	B dimension
DC	Ammeters	YM-206NDA	43	—	YM-208NDA	43	—	YM-210NDA	43	—
	Voltmeters	YM-206NDV	43	—	YM-208NDV	43	—	YM-210NDV	43	—
AC	Ammeters	YS-206NAA	43	—	YS-208NAA	43	—	YS-210NAA	43	—
		Uniform scale YR-206NAA	43	44	YR-208NAA	43	—	YR-210NAA	43	—
	Voltmeters	YS-206NAV	43	—	YS-208NAV	43	45	YS-210NAV	43	45
		Uniform scale YR-206NAV	43	—	YR-208NAV	43	—	YR-210NAV	43	—
	Wattmeters	YP-206NW	43	—	YP-208NW	43	—	YP-210NW	43	—
	Varmeters	YP-206NVAR	43	—	YP-208NVAR	43	—	YP-210NVAR	43	—
	Power-factor meters	Balanced YP-206NPF	43	—	YP-208NPF	43	—	YP-210NPF	43	—
		Unbalanced YP-206NPFU	43	—	YP-208NPFU	43	—	YP-210NPFU	43	—
Frequency meters	YP-206NF	83	—	YP-208NF	83	—	YP-210NF	83	—	
Receiving indicators	DC indicators	YM-206NRI	43	—	YM-208NRI	43	—	YM-210NRI	43	—
	AC indicators	YR-206NRI	43	—	YR-208NRI	43	—	YR-210NRI	43	—



Outer Dimensional Drawings

(Refer to the specification tables regarding models other than the Y-2N series, Y-N series, and L-N series.)

Wide-angle indicators (L-N Series)

FIG. 1 L-80N

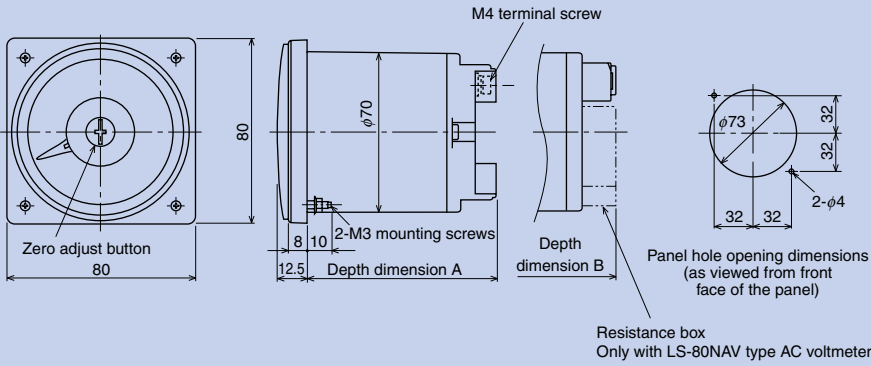

●Depth dimension details

Indicator type		L-80N			
		Type name	A dimension	B dimension	
DC	Ammeters	LM-80NDA	81	—	
	Voltmeters	LM-80NDV	81	—	
AC	Ammeters	LS-80NAA	—	81	
	Uniform scale	LR-80NAA	81	—	
	Voltmeters	LS-80NAV	—	81	
	Uniform scale	LR-80NAV	81	—	
	Wattmeters	LP-80NW	81	—	
	Varmeters	LP-80NVAR	81	—	
	Power-factor meters	Balanced	LP-80NPF	92	—
		Unbalance	LP-80NPFU	81	—
Frequency meters		LP-80NF	92	—	
Receiving indicators	DC indicators	LM-80NRI	81	—	
	AC indicators	LR-80NRI	81	—	



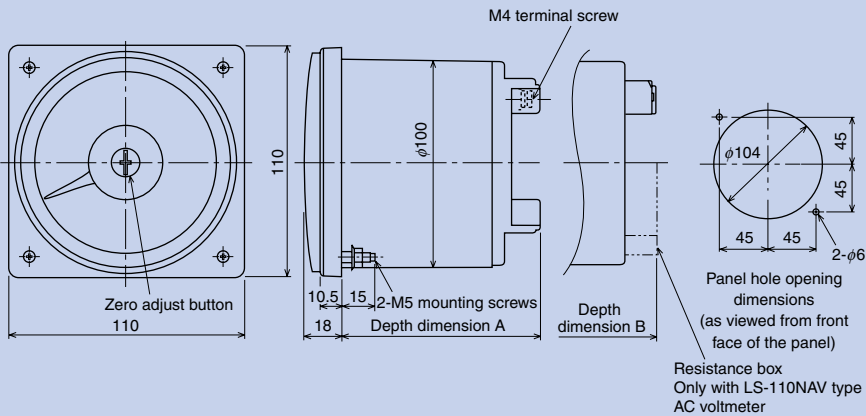



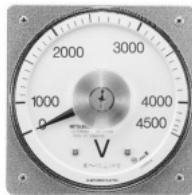



FIG. 2 L-110N



●Depth dimension details

Indicator type		L-110N			
		Type name	A dimension	B dimension	
DC	Ammeters	LM-110NDA	92	—	
	Voltmeters	LM-110NDV	92	—	
AC	Ammeters	LS-110NAA	—	92	
	Uniform scale	LR-110NAA	92	—	
	Voltmeters	LS-110NAV	—	92	
	Uniform scale	LR-110NAV	92	—	
	Wattmeters	LP-110NW	100	—	
	Varmeters	LP-110NVAR	100	—	
	Power-factor meters	Balanced	LP-110NPF	92	—
		Unbalance	LP-110NPFU	100	—
Frequency meters		LP-110NF	92	—	
Receiving indicators	DC indicators	LM-110NRI	92	—	
	AC indicators	LR-110NRI	92	—	

Covers

Cover specification	Classification	Y-2N Series	Y-N Series	L-N Series
B design cover (Munsell N 1.5 semi-gloss)	◎			
G design cover (all transparent)	○			—
F design cover ^{Note 1} (special color coating)	△			
Cover with red needle (can be manufactured for B, G, and F designs)	○			

Remarks The B design cover is standard specification. The G and F design covers and covers with red needles can be manufactured if required.

Note 1. When ordering the F-design cover, please use F as the cover code and specify the color coating. Munsell 7.5BG 4/1.5 will be used for orders with no color coating specified.

Cover codes

Cover specifications	Without red needle	With red needle
B design	B	BR*1
G design	G	GR
F design	F	FR

Remarks For the Y-N Series, a B cover with two red needles (BRR cover) can be manufactured depending on the model (please inquire for details).

Accessories

Nuts for mounting screws are provided with all models. T-150 and other special accessories are indicated in the specification columns of the respective indicator types.

Mechanical Indicators

Common Specifications

Scale plate components and items indicated

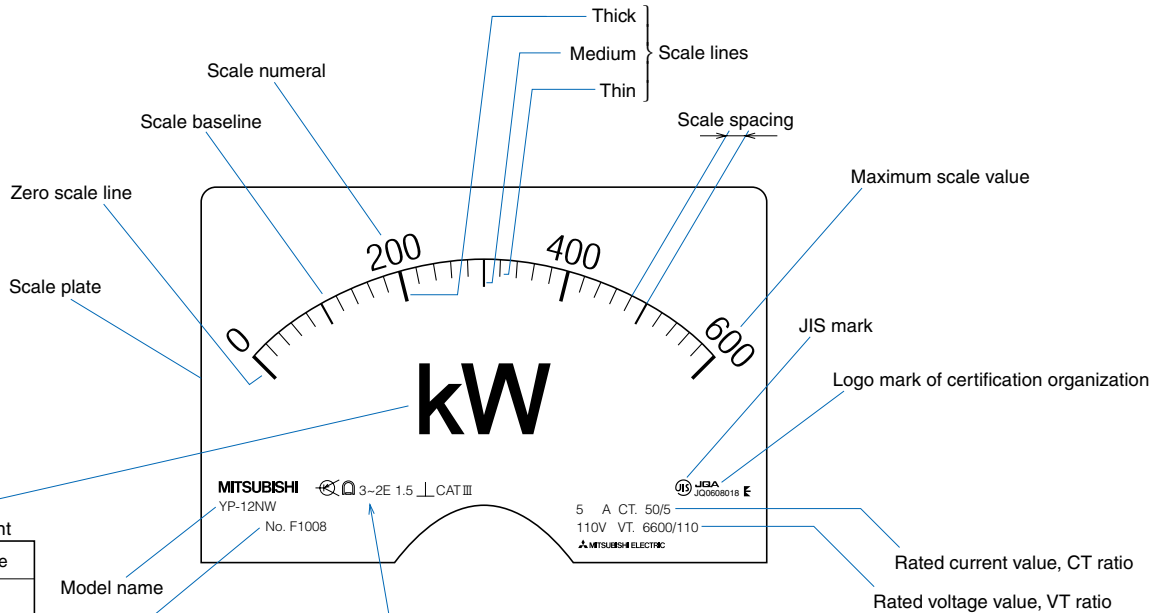

Unit of measurement

Item	Code
Ampere	A
Volt	V
Watt	W
Var	var
Power factor	cos ϕ or cos ψ
Hertz	Hz
Prefix	
Mega 10^6	M
Kilo 10^3	k
Milli 10^{-3}	m

Model name
Serial number

⊗ 3~2E 1.5 ⊥ CAT III

Auxiliary symbols

Item	Symbol
Shunt	
Serial resistor	
Accessory	

Operation principle

Item	Symbol
Permanent magnet/movable coil	
Movable iron core	
Bimetal	
Electronic device in measurement circuit	
Electronic device in auxiliary circuit	
Rectifier	

Type of measurement and number of elements measured

Item	Symbol
DC circuit	
AC circuit	
3-phase AC circuit	3~
Single element for 3-wire circuit	3-1E
Two elements for unbalanced load 3-wire circuit	3~2E
Two elements for unbalanced load 4-wire circuit	3N~2E
Three elements for unbalanced load 4-wire circuit	3N~3E

Accuracy class

Class index	Code
Class 0.5	0.5
Class 1	1
Class 1.5	1.5
Class 2.5	2.5
Class 5	5
Class 1.5 in the case where the base value corresponds to the span	1.5
Class 2.5 in the case where the base value corresponds to the span	2.5

Mounting attitude

Item	Symbol
Instrument used with scale plate set vertically	
Instrument used with scale plate set horizontally	
Instrument used with scale plate set at a position inclined from the horizontal surface (example: 60°)	

Measurement category

Classification	Code
Measurement category III	CAT III

Scale plate indications

The following tables show the scales, including numerals, colored lines, bands and colors, used as standard specifications. Red, blue, green and yellow are used for the colored lines/bands.

	Y-2N Series	Y-N Series	L-N Series
Standard scale			
Expanded scale (expanded by 3 times)			
Positive/Negative scale			
Single scale with double stamp			
Double scale with double stamp			
Colored lines Colored bands			

Remarks (1) See the "Standard Scale Diagrams" on pp.31 to 34 regarding the scale division with respect to the maximum scale value.
 (2) Special scales can also be manufactured.