

2.1 Model List

Frame			T10	T12	T20	T21	T25	T32	T35	T50	
Applicable standard			JIS C8201-4-1, IEC60947-4-1, EN60947-4-1, GB14048.4								
Model Name	Magnetic Contactors (Without Thermal Overload Relay, Open Type)	Non-Reversing	S-T10	S-T12	S-T20	S-T21	S-T25	S-T32	S-T35	S-T50	
		Reversing	S-2 x T10	S-2 x T12	S-2 x T20	S-2 x T21	S-2 x T25	S-2 x T32	S-2 x T35	S-2 x T50	
	Magnetic Starters (With standard 2-element, With Thermal Overload Relay)	Enclosed Type	Non-Reversing	MS-T10	MS-T12	—	MS-T21	—	—	MS-T35	MS-T50
			Reversing	—	—	—	MS-2 x T21	—	—	MS-2 x T35	MS-2 x T50
		Open Type	Non-Reversing	MSO-T10	MSO-T12	MSO-T20	MSO-T21	MSO-T25	—	MSO-T35	MSO-T50
			Reversing	MSO-2 x T10	MSO-2 x T12	MSO-2 x T20	MSO-2 x T21	MSO-2 x T25	—	MSO-2 x T35	MSO-2 x T50
	Combined Thermal Overload Relays			TH-T18			TH-T25			TH-T25 / T50	TH-T25 / T50
	Magnetic Starters With 3-element type Thermal Overload Relays	Enclosed Type	Non-Reversing	MS-T10KP	MS-T12KP	—	MS-T21KP	—	—	MS-T35KP	MS-T50KP
			Reversing	—	—	—	MS-2 x T21KP	—	—	MS-2 x T35KP	MS-2 x T50KP
		Open Type	Non-Reversing	MSO-T10KP	MSO-T12KP	MSO-T20KP	MSO-T21KP	MSO-T25KP	—	MSO-T35KP	MSO-T50KP
Reversing			MSO-2 x T10KP	MSO-2 x T12KP	MSO-2 x T20KP	MSO-2 x T21KP	MSO-2 x T25KP	—	MSO-2 x T35KP	MSO-2 x T50KP	
Combined Thermal Overload Relays			TH-T18KP			TH-T25KP			TH-T25 / T50KP	TH-T25 / T50KP	
Rated Insulation Voltage [V]			690								
Rated Impulse Withstand Voltage [kV]			6								
Rated Frequency [Hz]			50/60								
Pollution Degree			3								
Main contact rating	Rated operational current / power Category AC-3 (Note 1) (Three-phase squirrel-cage motor load standard responsibility) (Note 2) [kW/A]		AC220 to 240V	2.5/11 [2.2/11]	3.5/13 [2.7/13]	4.5/18 [3.7/18]	5.5/25 [4/20]	7.5/30 [5.5/28]	7.5/32 [7.5/32]	11/40 [7.5/35]	15/55 [11/50]
			AC380 to 440V	4/9 [2.7/7]	5.5/12 [4/9]	7.5/18 [7.5/18]	11/23 [7.5/20]	15/30 [11/25]	15/32 [15/32]	18.5/40 [15/32]	22/50 [22/48]
			AC500V	4/7 [2.7/6]	5.5/9 [5.5/9]	7.5/17 [7.5/17]	11/24 [11/20]	15/24 [11/20]	15/24 [11/20]	18.5/32 [15/26]	25/38 [22/38]
			AC690V	4/5	5.5/7	7.5/9	7.5/9	11/12	11/12	15/17	22/26
	Rated operational current / power Category AC-4 (Three-phase squirrel-cage motor load inching responsibility) [kW/A]		AC220 to 240V	1.5/8	2.2/11	3.7/18	4.5/20	5.5/26	5.5/26	5.5/26	7.5/35
			AC380 to 440V	2.2/6	4/9	5.5/13	7.5/17	11/24	11/24	11/24	15/32
			AC500V	2.7/6	5.5/9	5.5/10	7.5/12	7.5/13	11/17	15/24	15/24
	Rated operational current / power Category AC-1 (Resistance, heater load)		AC100 to 240V	20			32			60	80
			AC380 to 440V	11	13	13	32	32	60	80	
			AC500 to 550V	8	11	13	32	32	60	80	
Conventional Free Air Thermal Current I _{th} [A]			20			32			60	80	
Auxiliary contact rating	Contact Arrangement	Standard Accessory (Note 7)	Non-Reversing	1a	1a1b	2a2b	—	2a2b	2a2b	2a2b	
		Reversing (Note 8, Note 9)	1a x 2 + 2b	1a1b x 2 + 2b	2a2b x 2	—	2a2b x 2	2a2b x 2	2a2b x 2		
	Max. number of additional options (Note 11)	Non-Reversing	1 for UT-AX2/4, 2 for UT-AX11								
		Reversing (Note 8, Note 9)	2 for any UT-AX2/4/11								
	Rated Operating Current (Category AC-15: Alternating current coil load) [A]		AC120V	6	6	6	6	6	6	6	6
		AC240V	3	3	3	3	3	3	3	3	
Rated Operational Current (Category DC-13 : Direct current coil load)		DC24V	3								
		DC110V	0.6								
Conventional Free Air Thermal Current I _{th} [A]			10	10	10	10	10	10	10	10	
Performance	Mechanical Durability [x 10000]		1000								
	Electrical Durability (Note 5) [Ten thousand times]		Category AC-3	200 (Note 5, 6)							
			Category AC-4	3 (Note 5)							
			Category AC-1	50							
Switching Frequency [Times/Hour]		Category AC-3	1800							1200	
		Category AC-4	300								
		Category AC-1	1200								
Characteristic	Coil consumption (Note7) [VA]		Sealed	7	7	7	4.5	10	10	10	
			Inrush	45	45	75	55	110	110	110	
Power Consumption (Note 7) [W]			2.2	2.4	2.4	1.8	3.8	3.8	3.8		
Outside Dimensions	Magnetic Contactors (without Thermal Overload Relays) (Width x Height x Depth) [mm]		Non-Reversing	36 x 75 x 78	44 x 75 x 78	63 x 81 x 81	43 x 81 x 81	75 x 89 x 91	75 x 89 x 91	75 x 89 x 91	
			Reversing	82 x 85 x 78	98 x 85 x 78	136 x 81 x 81	96 x 81 x 111	160 x 114 x 97	160 x 114 x 97	160 x 114 x 97	
	Open Type Magnetic Starters (Width x Height x Depth) [mm]		Non-Reversing	46 x 115 x 79			63 x 128 x 82	—	75 x 157.5 x 91	75 x 157.5 x 91	
			Reversing	90.5 x 125 x 79	98.5 x 125 x 79	136 x 138 x 82	—	160 x 179 x 97	160 x 179 x 97	160 x 179 x 97	
Enclosed Magnetic Starters (Width x Height x Depth) [mm]		Non-Reversing	76 x 165 x 97.5			104 x 176 x 110	—	135 x 231 x 126	135 x 231 x 126		
		Reversing	—			220 x 192 x 115	—	300 x 247 x 130	300 x 247 x 130		
IEC 35mm rail mounting			Possible (excluding Enclosed Magnetic Starters)								
Installable Optional Unit Model Names (Note 10)	Additional Auxiliary Contact Units		(Contact Arrangement 1a1b)	UT-AX2/AX11							
			(Contact Arrangement 2a2b)	UT-AX4							
			With Low-Level Signal Contact	—							
			(Varistor) (Note 4)	UT-SA21							
	Coil Surge Absorber Units (Note 4)		(Varistor + Display LED)	UT-SA22							
			(CR)	UT-SA23							
			(Varistor + CR)	UT-SA25							
	DC-AC Interface		Triac Output	UT-SY21							
			Contact Output	UT-SY22							
	Live Part Protection Cover		For Magnetic Starters	Non-Reversing	—						
			Reversing	—							
		For Magnetic Contactors	Non-Reversing	—							
			Reversing	—							
Terminal Cover		For Magnetic Starters (Non-Reversing)	(Standard Equipment)								
		For Magnetic Contactors (Non-Reversing)	(Standard Equipment)								
Mechanical Interlock Units			UT-ML20 (Note 11)				UN-ML21				

Note 1. The figure in the square brackets indicates the rated current shown on the rating plate of the product at which the category AC-3 opening/closing durability. Note 2. The value between parentheses for the rated operating current is for the magnetic starter (with thermal overload relay). Note 3. AC operated types T10 to T50, DC operated types T12 to T50 can be manufactured with coil surge absorber (□-□SA type). The UT-SA21 type can be mounted. Note 4. T65 to N800 types have an integrated coil surge absorber rendering a coil surge absorber unit for prevention of coil switching surges unnecessary. Note 5. 1 million times for T20 class AC-3 380 V or more types for the rating in parentheses and 15,000 times for class AC-4 types. 15 thousand times for T35 to N800 class AC-4 380 V or more types. Note 6. Values are for the ratings in square brackets. The electrical durability for the current values not in parentheses varies inversely with the rough square of the current. Note 7. Mechanically latched types and delay open types have differing auxiliary contact arrangements. Refer to page 102 for details about mechanically latched types, or page 111 for delay open types.

T65	T80	T100	N125	N150	N180	N220	N300	N400	N600	N800
JIS C8201-4-1, IEC60947-4-1, EN60947-4-1, GB14048.4										
S-T65	S-T80	S-T100	S-N125	S-N150	S-N180	S-N220	S-N300	S-N400	S-N600	S-N800
S-2 x T65	S-2 x T80	S-2 x T100	S-2 x N125	S-2 x N150	S-2 x N180	S-2 x N220	S-2 x N300	S-2 x N400	S-2 x N600	S-2 x N800
MS-T65	MS-T80	MS-T100	MS-N125	MS-N150	MS-N180	MS-N220	MS-N300	MS-N400	—	—
MS-2 x T65	MS-2 x T80	MS-2 x T100	MS-2 x N125	MS-2 x N150	MS-2 x N180	MS-2 x N220	MS-2 x N300	MS-2 x N400	—	—
MSO-T65	MSO-T80	MSO-T100	MSO-N125	MSO-N150	MSO-N180	MSO-N220	MSO-N300	MSO-N400	—	—
MSO-2 x T65	MSO-2 x T80	MSO-2 x T100	MSO-2 x N125	MSO-2 x N150	MSO-2 x N180	MSO-2 x N220	MSO-2 x N300	MSO-2 x N400	—	—
TH-T65	TH-T65 / T100	TH-T65 / T100	TH-N120(TA)	TH-N120(TA)	TH-N220RH	TH-N220RH	TH-N400RH	TH-N400RH	TH-N600(+CT)	TH-N600(+CT)
MS-T65KP	MS-T80KP	MS-T100KP	MS-N125KP	MS-N150KP	MS-N180KP	MS-N220KP	MS-N300KP	MS-N400KP	—	—
MS-2 x T65KP	MS-2 x T80KP	MS-2 x T100KP	MS-2 x N125KP	MS-2 x N150KP	MS-2 x N180KP	MS-2 x N220KP	MS-2 x N300KP	MS-2 x N400KP	—	—
MSO-T65KP	MSO-T80KP	MSO-T100KP	MSO-N125KP	MSO-N150KP	MSO-N180KP	MSO-N220KP	MSO-N300KP	MSO-N400KP	—	—
MSO-2 x T65KP	MSO-2 x T80KP	MSO-2 x T100KP	MSO-2 x N125KP	MSO-2 x N150KP	MSO-2 x N180KP	MSO-2 x N220KP	MSO-2 x N300KP	MSO-2 x N400KP	—	—
TH-T65KP	TH-T65 / T100KP	TH-T65 / T100KP	TH-N120(TA)KP	TH-N120(TA)KP	TH-N220RHKP	TH-N220RHKP	TH-N400RHKP	TH-N400RHKP	TH-N600KP(+CT)	TH-N600KP(+CT)
690					690 (1000)					
6					6 (8)					
50/60										
3										
18.5/65 [15/65]	22/85 [19/80]	30/105 [22/100]	37/125 [30/125]	45/150 [37/150]	55/180 [45/180]	75/250 [55/220]	90/300 [75/300]	125/400 [110/400]	190/630 [160/630]	220/800 [200/800]
30/65 [30/65]	45/85 [37/80]	55/105 [45/93]	60/120 [60/120]	75/150 [75/150]	90/180 [90/180]	132/250 [110/220]	160/300 [150/300]	220/400 [200/400]	330/630 [300/630]	440/800 [400/800]
37/60 [30/45]	45/75 [45/75]	55/85 [45/75]	60/90 [60/90]	90/140 [90/140]	110/180 [110/180]	132/200 [132/200]	160/250 [160/250]	225/350 [200/350]	330/500 [300/500]	500/720 [400/720]
30/38	45/52	55/65	60/70	90/100	110/120	132/150	200/220	250/300	330/420	500/630
11/50	15/65	19/80	22/93	30/125	37/150	45/180	55/220	75/300	110/400	160/630
22/47	30/62	37/75	45/90	55/110	75/150	90/180	110/220	150/300	200/400	300/630
22/38	30/45	37/55	45/65	55/80	75/140	90/140	110/200	150/250	200/350	300/500
100	120	150	150	200	260	260	350	450	660	800
100	120	150	150	200	260	260	350	450	660	800
100	120	150	150	200	260	260	350	450	660	800
100	120	150	150	200	260	260	350	450	660	800
2a2b	2a2b	2a2b	2a2b	2a2b	2a2b	2a2b	2a2b	2a2b	2a2b	2a2b
2a2b x 2	2a2b x 2	2a2b x 2	2a2b x 2	3a3b x 2	3a3b x 2	3a3b x 2	3a3b x 2	3a3b x 2	4a4b x 2	4a4b x 1
1 for UT-AX2/4, 2 for UT-AX11		2 for UN-AX80			2 for UN-AX150				1 for UN-AX600	
2 for any UT-AX2/4/11		2 for UN-AX80			—	—	—	—	—	—
6	6	6	6	6	6	6	6	6	6	6
3	3	3	3	3	3	3	3	3	3	3
3		3			3				3	
0.6										
10	10	10	10	10	10	10	10	10	10	10
500										
200	100 (Note 6)						50 (Note 6)			
3 (Note 5)										
50										
1200										
300										
1200		600								
20	23	24	24	40	40	50	50	90	90	
115	210	270	270	440	440	440	440	790	790	
2.2	2.2	2.8	2.9	2.9	4.2	4.2	6.1	6.1	17	
88 x 106 x 106	88 x 106 x 106	100 x 124 x 127	100 x 150 x 137	120 x 160 x 145	138 x 204 x 175	138 x 204 x 175	163 x 243 x 195	163 x 243 x 195	290 x 310 x 235	290 x 310 x 235
216 x 115 x 112	216 x 115 x 112	270 x 140 x 137	276 x 150 x 148	296 x 160 x 156	370 x 215 x 189	370 x 215 x 189	395 x 250 x 209	395 x 250 x 209	660 x 435 x 254	660 x 435 x 254
90 x 158 x 106	90 x 174.5 x 106	100 x 196 x 127	112 x 239 x 137	120 x 250 x 145	144 x 282 x 180.5	144 x 282 x 180.5	163 x 360 x 195	163 x 360 x 195	—	—
216 x 169 x 112	216 x 185.5 x 112	270 x 213 x 137	276 x 251 x 148	296 x 276 x 156	370 x 304 x 194.5	370 x 304 x 194.5	395 x 392 x 209	395 x 392 x 209	—	—
160 x 282 x 145	190 x 317 x 163	230 x 396 x 190	—	270 x 496 x 209	—	—	—	—	—	—
320 x 282 x 140	410 x 347 x 154	440 x 436 x 170	—	520 x 536 x 209	—	—	600 x 616 x 230	—	—	—
Possible (excluding Enclosed Magnetic Starters)										
UN-AX2/AX11		UN-AX80			UN-AX150				UN-AX600	
UN-AX4		—			—				—	
UN-LL22		—			—				—	
—		—			—				—	
—		—			—				—	
—		—			—				—	
UN-SY31		—			—				—	
UN-SY32		—			—				—	
UN-CZ500 + UN-CZ501		UN-CZ800+ UN-CZ801	UN-CZ1250+ UN-CZ1251	UN-CZ1500+ UN-CZ1501	UN-CZ2200 + UN-CZ2201		UN-CZ3000 + UN-CZ3001		—	—
UN-CZ504		UN-CZ804	UN-CZ1254	UN-CZ1504	UN-CZ2204		UN-CZ3004		—	—
UN-CZ500 x 2		UN-CZ800 x 2	UN-CZ1250 x 2	UN-CZ1500 x 2	UN-CZ2200 x 2		UN-CZ3000 x 2		—	—
UN-CZ502		UN-CZ802	UN-CZ1252	UN-CZ1502	UN-CZ2202		UN-CZ3002		—	—
UT-CW800 + UT-CW655		—			—				—	
UT-CW800		—			—				—	
UN-ML21		UN-ML80		UN-ML150	UN-ML220					

Note 8. The +2b on the auxiliary contact arrangement of reversible T10 to T20 types indicates the break contact of the integrated UT-ML20 interlock unit.

There is no need to specify when ordering.

Note 9. Auxiliary contact arrangements for reversible types are displayed by twos, in a contact arrangement combined with two magnetic contactors. For standard contact arrangements there is no need to specify the ordering; however, please specify a matching contact arrangement for 2 units if for a special configuration. <Example> For 1b x 2 + 2b: 2B

Note 10. Because there are products that cannot be mounted, please refer to combination details on page 192 when applying optional products.

Note 11. Not applicable to AC operated types produced before March, 2019.

2.2 Manufacturing Range List

● Non-Reversible Type

Frame		T10	T12	T20	T21	T25	T32	T35	T50	T65	T80	T100	N125	N150	N180	N220	N300	N400	N600	N800				
Category AC-3	220V	2.5	3.5	4.5	5.5	7.5	7.5	11	15	18.5	22	30	37	45	55	75	90	125	190	220				
	Rated Capacity [kW]	440V	4	5.5	7.5	11	15	15	18.5	22	30	45	55	60	75	90	132	160	220	330	440			
Auxiliary Contact	Standard	1a	1a1b	1a1b	←2a2b→		←2a2b→																	
	Special	1b	2a (Note 8)	2a (Note 8)	—	—	—	—	—	—	—	—	—	—	—	—	—	—	—	—	—			
Model Name		(Note 6)																						
Magnetic Starters	Enclosed	Standard Specifications	MS-□	○	○	—	○	—	—	○	○	○	○	○	○	○	○	○	○	○	○	—	—	
		With Push-Button	MS-□PM	○	○	—	○	—	—	○	○	○	○	○	—	—	—	—	—	—	—	—	—	—
		3-Element (2E) Thermal	MS-□KP	○	○	—	○	—	—	○	○	○	○	○	○	○	○	○	○	○	○	○	—	—
		Open Time Quick Motion Type	MS-□QM	—	—	—	—	—	—	—	○	○	○	○	○	○	○	○	○	○	○	○	—	—
	Open Type	Standard Specifications	MSO-□	○	○	○	○	○	—	○	○	○	○	○	○	○	○	○	○	○	○	○	—	—
			MSOD-□	—	○	○	○	—	—	○	○	○	○	○	○	○	—	○	○	○	○	○	—	—
		3-Element (2E) Thermal	MSO-□KP	○	○	○	○	○	—	○	○	○	○	○	○	○	○	○	○	○	○	○	—	—
			MSOD-□KP	—	○	○	○	—	—	○	○	○	○	○	○	○	—	○	○	○	○	○	—	—
		With Saturable Reactor	MSO-□SR	○	○	○	○	○	—	○	○	○	○	○	○	○	○	○	○	○	○	○	—	—
			MSOD-□SR	—	○	○	○	—	—	○	○	○	○	○	○	○	—	○	○	○	○	○	—	—
		With 3-Element (2E) Thermal Saturable Reactor	MSO-□KPSR	—	—	—	○	○	—	○	○	○	○	○	○	○	○	○	○	○	○	○	—	—
			MSOD-□KPSR	—	—	—	○	—	—	○	○	○	○	○	○	○	—	○	○	○	○	○	—	—
		2-Element Quick-acting Characteristics Thermal	MSO-□FS	—	—	—	○	○	—	○	○	○	○	○	—	—	—	—	—	—	—	—	—	—
			MSOD-□FS	—	—	—	○	—	—	○	○	○	○	○	—	—	—	—	—	—	—	—	—	—
		3-Element (2E) Quick-acting Characteristics Thermal	MSO-□FSKP	○	○	○	○	○	—	○	○	○	○	○	—	—	—	—	—	—	—	—	—	—
			MSOD-□FSKP	—	○	○	○	—	—	○	○	○	○	○	—	—	—	—	—	—	—	—	—	—
		Open Time Quick Motion Type	MSO-□QM	—	—	—	—	—	—	—	—	○	○	○	○	○	○	○	○	○	○	○	—	—
			MSOD-□QM	—	—	—	—	—	—	—	—	○	○	○	○	○	○	○	○	○	○	○	—	—
	Surge Absorber Mounted Type	MSO-□SA	○	○	○	○	○	—	○	○	—	—	—	—	—	—	—	—	—	—	—	—	—	
		MSOD-□SA	—	○	○	○	—	—	○	○	—	—	—	—	—	—	—	—	—	—	—	—	—	
	Wiring Streamlining Terminal	MSO-□BC	○	○	○	○	○	—	○	○	—	—	—	—	—	—	—	—	—	—	—	—	—	
		MSOD-□BC	—	○	○	○	—	—	○	○	—	—	—	—	—	—	—	—	—	—	—	—	—	
	Anticorrosion Treatment	MSO-□YS	○	○	○	○	○	—	○	○	○	○	○	○	○	○	○	○	○	○	○	—	—	
		MSOD-□YS	—	○	○	○	—	—	○	○	○	○	○	○	○	—	○	○	○	○	○	—	—	
	Delay Open Type	MSO-□DL	—	○	—	○	—	—	○	○	○	○	○	—	○	—	○	○	○	○	○	—	—	
		MSOD-□DL	—	○	—	○	—	—	○	○	○	○	○	—	○	—	○	○	○	○	○	—	—	
	Mechanically Latched Type	MSOL-□	—	—	—	○	—	—	○	○	○	○	○	○	○	—	○	○	○	○	○	—	—	
		MSOLD-□	—	—	—	○	—	—	○	○	○	○	○	○	○	—	○	○	○	○	○	—	—	
With Terminal Cover	MSO-□CW	—	—	—	—	—	—	—	—	○	○	○	○	○	○	○	○	○	○	○	○	○		
	MSOD-□CW	—	—	—	—	—	—	—	—	○	○	○	○	○	○	○	○	○	○	○	○	○		
Magnetic Contactors	Open Type	Standard Specifications	S-□	○	○	○	○	○	○	○	○	○	○	○	○	○	○	○	○	○	○	○	○	
			SD-□	—	○	○	○	—	○	○	○	○	○	○	○	○	—	○	○	○	○	○	○	
		Surge Absorber Mounted Type	S-□SA(Note3)	○	○	○	○	○	○	○	○	—	—	—	—	—	—	—	—	—	—	—	—	—
			SD-□SA	—	○	○	○	—	○	○	○	—	—	—	—	—	—	—	—	—	—	—	—	—
		Anticorrosion Treatment	S-□YS	—	—	—	—	—	—	○	○	○	○	○	○	○	○	○	○	○	○	○	○	○
			S-□QM	—	—	—	—	—	—	—	—	○	○	○	○	○	○	○	○	○	○	○	—	—
		Wiring Streamlining Terminal	S-□BC	○	○	○	○	○	○	○	○	—	—	—	—	—	—	—	—	—	—	—	—	—
			SD-□BC	—	○	○	○	—	○	○	○	—	—	—	—	—	—	—	—	—	—	—	—	—
		With Spring Clamp Terminals	S-□SQ	—	○	○	—	—	—	—	—	—	—	—	—	—	—	—	—	—	—	—	—	—
			SD-□SQ	—	○	○	—	—	—	—	—	—	—	—	—	—	—	—	—	—	—	—	—	—
		With Terminal Cover	S-□CW	—	—	—	—	—	—	—	—	○	○	○	○	○	○	○	○	○	○	○	○	○
			SD-□CW	—	—	—	—	—	—	—	—	○	○	○	○	○	○	○	○	○	○	○	○	○
		Delay Open Type	S-□DL	—	○	—	○	—	—	○	○	○	○	○	—	○	—	○	○	○	○	○	—	—
			SD-□DL	—	○	—	○	—	—	○	○	○	○	○	—	○	—	○	○	○	○	○	—	—
Mechanically Latched Type	SL-□	—	—	—	○	—	—	○	○	○	○	○	○	○	—	○	○	○	○	○	○	○		
	SLD-□	—	—	—	○	—	—	○	○	○	○	○	○	○	—	○	○	○	○	○	○	○		

● Reversible Type

Frame		2 x T10	2 x T12	2 x T20	2 x T21	2 x T25	2 x T32	2 x T35	2 x T50	2 x T65	2 x T80	2 x T100	2 x N125	2 x N150	2 x N180	2 x N220	2 x N300	2 x N400	2 x N600	2 x N800		
Category AC-3	220V	2.5	3.5	4.5	5.5	7.5	7.5	11	15	18.5	22	30	37	45	55	75	90	125	190	220		
	Rated Capacity [kW]	440V	4	5.5	7.5	11	15	15	18.5	22	30	45	55	60	75	90	132	160	220	330	440	
Auxiliary Contact (Note 4 to Note 6)	Standard	(1a x 2) + 2b	(1a1b x 2) + 2b	2a2b x 2										3a3b x 2					4a4b x 2			
	Special	(1b x 2) + 2b	(2a x 2) + 2b	-	-	-	-	-	-	-	-	-	-	-	-	-	-	-	-	-	-	
Model	Standard Specifications	MS-□	○	○	○	○	○	○	○	○	○	○	○	○	○	○	○	○	○	○	○	
Magnetic Starters	3-Element (2E) Thermal	MS-□KP	○	○	○	○	○	○	○	○	○	○	○	○	○	○	○	○	○	○	○	
	Standard Specifications	MSO-□	◎	◎	◎	◎	◎	◎	◎	◎	◎	◎	◎	◎	◎	◎	◎	◎	◎	◎	◎	
	3-Element (2E) Thermal	MSO-□KP	○	○	○	○	○	○	○	○	○	○	○	○	○	○	○	○	○	○	○	○
		MSOD-□KP	○	○	○	○	○	○	○	○	○	○	○	○	○	○	○	○	○	○	○	○
	With Saturable Reactor	MSO-□SR	○	○	○	○	○	○	○	○	○	○	○	○	○	○	○	○	○	○	○	○
		MSOD-□SR	○	○	○	○	○	○	○	○	○	○	○	○	○	○	○	○	○	○	○	○
	With 3-Element (2E) Thermal Saturable Reactor	MSO-□KPSR	○	○	○	○	○	○	○	○	○	○	○	○	○	○	○	○	○	○	○	○
		MSOD-□KPSR	○	○	○	○	○	○	○	○	○	○	○	○	○	○	○	○	○	○	○	○
	2-Element Quick-acting Characteristics Thermal	MSO-□FS	○	○	○	○	○	○	○	○	○	○	○	○	○	○	○	○	○	○	○	○
		MSOD-□FS	○	○	○	○	○	○	○	○	○	○	○	○	○	○	○	○	○	○	○	○
	3-Element (2E) Quick-acting Characteristics Thermal	MSO-□FSKP	○	○	○	○	○	○	○	○	○	○	○	○	○	○	○	○	○	○	○	○
		MSOD-□FSKP	○	○	○	○	○	○	○	○	○	○	○	○	○	○	○	○	○	○	○	○
	Surge Absorber Mounted Type	MSO-□SA	○	○	○	○	○	○	○	○	○	○	○	○	○	○	○	○	○	○	○	○
		MSOD-□SA	○	○	○	○	○	○	○	○	○	○	○	○	○	○	○	○	○	○	○	○
	Wiring Streamlining Terminal	MSO-□BC	○	○	○	○	○	○	○	○	○	○	○	○	○	○	○	○	○	○	○	○
		MSOD-□BC	○	○	○	○	○	○	○	○	○	○	○	○	○	○	○	○	○	○	○	○
	With Terminal Cover	MSO-□CW	○	○	○	○	○	○	○	○	○	○	○	○	○	○	○	○	○	○	○	○
		MSOD-□CW	○	○	○	○	○	○	○	○	○	○	○	○	○	○	○	○	○	○	○	○
	Anticorrosion Treatment	MSO-□YS	○	○	○	○	○	○	○	○	○	○	○	○	○	○	○	○	○	○	○	○
		MSOD-□YS	○	○	○	○	○	○	○	○	○	○	○	○	○	○	○	○	○	○	○	○
Mechanically Latched Type	MSOL-□	○	○	○	○	○	○	○	○	○	○	○	○	○	○	○	○	○	○	○	○	
	MSOLD-□	○	○	○	○	○	○	○	○	○	○	○	○	○	○	○	○	○	○	○	○	
Magnetic Contactors	Standard Specifications	S-□	◎	◎	◎	◎	◎	◎	◎	◎	◎	◎	◎	◎	◎	◎	◎	◎	◎	◎	◎	
	Surge Absorber Mounted Type	SD-□	○	○	○	○	○	○	○	○	○	○	○	○	○	○	○	○	○	○	○	
	Surge Absorber Mounted Type	S-□SA(Note 3)	○	○	○	○	○	○	○	○	○	○	○	○	○	○	○	○	○	○	○	○
		SD-□SA	○	○	○	○	○	○	○	○	○	○	○	○	○	○	○	○	○	○	○	○
	Anticorrosion Treatment	S-□YS	○	○	○	○	○	○	○	○	○	○	○	○	○	○	○	○	○	○	○	○
	Wiring Streamlining Terminal	S-□BC	○	○	○	○	○	○	○	○	○	○	○	○	○	○	○	○	○	○	○	○
		SD-□BC	○	○	○	○	○	○	○	○	○	○	○	○	○	○	○	○	○	○	○	○
	With Terminal Cover	S-□CW	○	○	○	○	○	○	○	○	○	○	○	○	○	○	○	○	○	○	○	○
		SD-□CW	○	○	○	○	○	○	○	○	○	○	○	○	○	○	○	○	○	○	○	○
	Mechanically Latched Type	SL-□	○	○	○	○	○	○	○	○	○	○	○	○	○	○	○	○	○	○	○	○
		SLD-□	○	○	○	○	○	○	○	○	○	○	○	○	○	○	○	○	○	○	○	○
	Class 2 Heat Resistance	S-□FN	○	○	○	○	○	○	○	○	○	○	○	○	○	○	○	○	○	○	○	○
	With Reversing Connecting Conductor (Both Power and Load Sides)	S-□SD	○	○	○	○	○	○	○	○	○	○	○	○	○	○	○	○	○	○	○	○
		SD-□SD	○	○	○	○	○	○	○	○	○	○	○	○	○	○	○	○	○	○	○	○
	With Power Side 3-Pole In-Phase Crossover Conductor	S-□SG	○	○	○	○	○	○	○	○	○	○	○	○	○	○	○	○	○	○	○	○
		SD-□SG	○	○	○	○	○	○	○	○	○	○	○	○	○	○	○	○	○	○	○	○
	With Load Side 3-Pole In-Phase Crossover Conductor	S-□SX	○	○	○	○	○	○	○	○	○	○	○	○	○	○	○	○	○	○	○	○
		SD-□SX	○	○	○	○	○	○	○	○	○	○	○	○	○	○	○	○	○	○	○	○
	With Load Side 3-Pole Reverse-Phase Switching Crossover Conductor	S-□SF	○	○	○	○	○	○	○	○	○	○	○	○	○	○	○	○	○	○	○	○
		SD-□SF	○	○	○	○	○	○	○	○	○	○	○	○	○	○	○	○	○	○	○	○

- Note 1. ◎ : Permanently in stock, depending on operation coil voltage and heater designation. ○ : Made to order.
- : Outside production range
- Note 2. The value between parentheses for the class AC-3 rated capacity applies to an enclosed magnetic starter.
- Note 3. T65 to N800 types have an AC control coil integrated surge absorber, rendering a coil surge absorber unit for prevention of coil switching surges unnecessary.
- Note 4. The +2b on the auxiliary contact arrangement of reversible T10 to T20 types indicates the break contact of the integrated UT-ML20 interlock unit. There is no need to specify when ordering.
- Note 5. Auxiliary contact arrangements for reversible types are displayed by twos, in a contact arrangement combining two magnetic contactors. For standard contact arrangements there is no need to specify when ordering; however, please specify a matching contact arrangement for 2 units if for a special configuration.
<Example> For 1b x 2 + 2b: 2B
- Note 6. Mechanically latched types and delay open types have differing auxiliary contact arrangements. Refer to page 102 for details about mechanically latched types, or page 111 for delay open types.
- Note 7. MSO(D)-(2x)T80CW(KP) heater designation 67A is not manufactured.
- Note 8. S-T12/T20 auxiliary contact 2b can be manufactured.

4.1 MS/MSO/S-□ Standard (AC Operated) Magnetic Starters/Magnetic Contactors

A high quality product that supports the various needs of our customers on a global scale.

- Usable in general applications such as motor starting, stopping, and burnout protection.
- Adopts twin contacts for the auxiliary contacts across all series for high reliability.
- Our standard products comply with the domestic standards as well as various overseas standards and are certified as meeting all standards. (Refer to page 266 for details.)

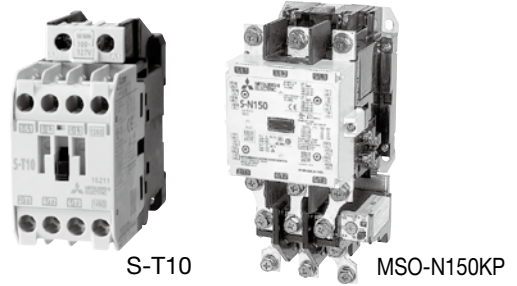

● Ratings/Specifications (Standard Applicability)

Magnetic Contactors	Magnetic Starters (Note 12)	Rated Capacity [kW]				Rated Operating Current [A]				Conventional Free Air Thermal Current [A]	Auxiliary Contact		Compatible Thermal Overload Relays			
		Three-Phase Squirrel-cage Motor (Category AC-3)				Three-Phase Squirrel-cage Motor (Category AC-3)					Resistive Load (Category AC-1)		Standard (Special)	Additional Unit Model Names x Pieces	Model Name	Heater Designation Range [A]
		AC220 to 240 V	AC380 to 440 V	AC500 V	AC690 V	AC220 to 240 V	AC380 to 440 V	AC500 V	AC690 V		AC100 to 240 V	AC380 to 440 V				
S-T10(BC)	MSO-T10(BC)KP	2.5[2.2]	4[2.7]	4[2.7]	4	11[11]	9[7]	7[6]	5	20	11	20	1a(1b)		0.12 to 9	
S-T12(BC)	MSO-T12(BC)KP	3.5[2.7]	5.5[4]	5.5[5.5]	5.5	13[13]	12[9]	9[9]	7	20	13	20	1a1b (2a, 2b)	TH-T18(BC)KP	0.12 to 11 0.12 to 15	
S-T20(BC)	MSO-T20(BC)KP	4.5[3.7]	7.5[7.5]	7.5[7.5]	7.5	18[18]	18[18]	17[17]	9	20	18	20	2a2b		0.24 to 22	
S-T21(BC)	MSO-T21(BC)KP	5.5[4] (Note 3)	11[7.5]	11[7.5]	7.5	25[20]	23[20]	17[17]	9	32	32	32	2a2b		0.24 to 22	
S-T25(BC)	MSO-T25(BC)KP	7.5 [5.5]	15[11]	15[11]	11	30[26] (Note 1)	30[26] (Note 1)	24[20]	12	32	32	32	2a2b	UT-AX2, 4(BC) x 1 or UT-AX11(BC) x 2	TH-T25(BC)KP 0.24 to 22	
S-T32(BC)	—	7.5 [7.5]	15[15]	15[11]	11	32[32]	32[32]	24[20]	12	32	32	32	—	—	—	
S-T35(BC)	MSO-T35(BC)KP	11[7.5]	18.5[15]	18.5[15]	15	40[35]	40[32]	32[26]	17	60	60	60	2a2b	TH-T25(BC)KP TH-T50(BC)KP	0.24 to 22 29	
S-T50(BC)	MSO-T50(BC)KP	15[11]	22[22]	25[22]	22	55[50] (Note 1)	50[48]	38[38]	26	80	80	80		TH-T25(BC)KP TH-T50(BC)KP	0.24 to 22 29 to 42	
S-T65(CW)	MSO-T65(CW)KP	18.5[15]	30[30]	37[30]	30	65[65]	65[65]	60[45]	38	100	100	100		UN-AX2, 4 x 1 or UN-AX11 x 2	TH-T65KP	15 to 54
S-T80(CW)	MSO-T80(CW)KP (Note 10)	22[19]	45[37]	45[45]	45	85[80]	85[80]	75[75]	52	120	120	120		UN-AX80 x 2	TH-T100KP (Note 4)	67
S-T100	MSO-T100KP	30[22]	55[45]	55[45]	55	105[100]	105[93]	85[75]	65	150	150	150	UN-AX150 x 2	TH-T65KP TH-T100KP	15 to 54 67, 82	
S-N125	MSO-N125KP	37[30]	60[60]	60[60]	60	125[125]	120[120]	90[90]	70	150	150	150	UN-AX150 x 2	TH-N120KP (TA)	42 to 105	
S-N150	MSO-N150KP	45[37]	75[75]	90[90]	90	150[150]	150[150]	140[140]	100	200	200	200		TH-N220KPRH	82 to 150	
S-N180	MSO-N180KP	55[45]	90[90]	110[110]	110	180[180]	180[180]	180[180]	120	260	260	260	UN-AX150 x 2	TH-N400KPRH	105 to 250 105 to 330	
S-N220	MSO-N220KP	75[55]	132[110]	132[132]	132	250[220]	250[220]	200[200]	150	260	260	260		TH-N600KP (Note 5)	250 to 500	
S-N300	MSO-N300KP	90[75]	160[150]	160[160]	200	300[300]	300[300]	250[250]	220	350	350	350	UN-AX600 x 1		250 to 660	
S-N400	MSO-N400KP	125[110]	220[200]	225[200]	250	400[400]	400[400]	350[350]	300	450	450	450				
S-N600	—	190[160]	330[300]	330[300]	330	630[630]	630[630]	500[500]	420	660	660	660				
S-N800	—	220[200]	440[400]	500[400]	500	800[800]	800[800]	720[720]	630	800	800	800				

- Note 1. The value in parentheses for the rated operating current is applicable in the case of magnetic contactors.
- Note 2. Enclosed type magnetic starters are of MS-□ type. T20, T25, T32 and N600, N800 types are outside production range. It should be noted that auxiliary contact units cannot be additionally installed to enclosed types. MS-T□DP is for single-phase motors. Refer to page 267 article 10.3 for details about production range or applicable capacities.
- Note 3. MS-T21 type with 200 to 220 V ratings are 3.7 kW, in accordance with the Electrical Appliance and Material Safety Law.
- Note 4. Enclosed type heater designation 67A uses a thermal overload relay dedicated for enclosed types.
- Note 5. Please use TH-N600 in combination with a separately sold current transformer (Mitsubishi CW-□).
- Note 6. Refer to page 51 for information regarding application to resistive loads and capacitive loads.
- Note 7. The main contact minimum operating voltage and current differ depending on the allowable fault rate. Refer to page 42 for details.
- Note 8. "BC" in the model name refers to "wiring streamlining terminal".
- Note 9. T65 to T100 and N125 to N800 are AC operated, DC energizing types, which may become unusable or undergo property alteration depending on the control circuit conditions. Carefully read page 71 before use.
- Note 10. MSO-T80CW heater designation 67A is not manufactured.
- Note 11. MSO-T□ and MSO-N□ types can also be manufactured.
- Note 12. S-T12 and S-T20 with spring clamp terminals (SQ) can also be manufactured.

Item	Reference Page	Remarks
· Main Contact Rating	Page 39	—
· Auxiliary Contact Rating	Page 41	—
· Operation Coil	Page 43	—
· Properties	Page 45	—
· Performance	Page 46	—
· Outline Drawings/Contact Arrangements	Page 77	—
· How to Order	Page 130	—
· Combining with Optional Units	Page 194	—

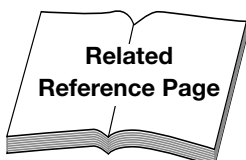

4.2 MS/MSO/S-2x□ Reversible Magnetic Starters/ Magnetic Contactors

Ideal for forward/reverse operation of AC motors

- Ideal for forward rotation, reverse rotation, or plugging, as well as for the switching of normal and emergency power supplies.
- A highly reliable mechanical interlock is equipped as standard.



MSO-2xT21KP

● Ratings/Specifications (Standard Applicability)

Magnetic Contactors	Magnetic Starters (Note 12)	Rated Capacity [kW]				Rated Operating Current [A]						Conventional Free Air Thermal Current Ith [A]	Auxiliary Contact		Compatible Thermal Overload Relays	
		Three-Phase Squirrel-cage Motor (Category AC-3)				Three-Phase Squirrel-cage Motor (Category AC-3)				Resistive Load (Category AC-1)			Standard (Special)	Additional Unit Model Names x Pieces	Model Name	Heater Designation Range [A]
		AC220 to 240 V	AC380 to 440 V	AC500 V	AC690 V	AC220 to 240 V	AC380 to 440 V	AC500 V	AC690 V	AC100 to 240 V	AC380 to 440 V					
S-2xT10(BC)	MSO-2xT10(BC)KP	2.5[2.2]	4[2.7]	4[2.7]	4	11[11]	9[7]	7[6]	5	20	11	20	1a x 2 + 2b (1b x 2 + 2b)			0.12 to 9
S-2xT12(BC)	MSO-2xT12(BC)KP	3.5[2.7]	5.5[4]	5.5[5.5]	5.5	13[13]	12[9]	9[9]	7	20	13	20	1a1b x 2 + 2b (2a x 2 + 2b)		TH-T18(BC)KP	0.12 to 11
S-2xT20(BC)	MSO-2xT20(BC)KP	4.5[3.7]	7.5[7.5]	7.5[7.5]	7.5	18[18]	18[18]	17[17]	9	20	18	20	1a1b x 2 + 2b (2a x 2 + 2b)	UT-AX2, 4(BC) x 2 or UT-AX11(BC) x 2		0.12 to 15
S-2xT21(BC)	MSO-2xT21(BC)KP	5.5[4] (Note 3)	11[7.5]	11[7.5]	7.5	25[20]	23[20]	17[17]	9	32	32	32			TH-T25(BC)KP	0.24 to 22
S-2xT25(BC)	MSO-2xT25(BC)KP	7.5[5.5]	15[11]	15[11]	11	30[26][26] (Note 1)	30[26][25] (Note 1)	24[20]	12	32	32	32				0.24 to 22
S-2xT32(BC)	—	7.5[7.5]	15[15]	15[11]	11	32[32]	32[32]	24[20]	12	32	32	32		—	—	—
S-2xT35(BC)	MSO-2xT35(BC)KP	11[7.5]	18.5[15]	18.5[15]	15	40[35]	40[32]	32[26]	17	60	60	60			TH-T25(BC)KP	0.24 to 22
S-2xT50(BC)	MSO-2xT50(BC)KP	15[11]	22[22]	25[22]	22	55[50][50] (Note 1)	50[48]	38[38]	26	80	80	80	2a2b x 2	UT-AX2, 4(BC) x 2 or UT-AX11(BC) x 2	TH-T50(BC)KP	0.24 to 22
S-2xT65(CW)	MSO-2xT65(CW)KP	18.5[15]	30[30]	37[30]	30	65[65]	65[65]	60[45]	38	100	100	100			TH-T65KP	15 to 54
S-2xT80(CW)	MSO-2xT80(CW)KP (Note 11)	22[19]	45[37]	45[45]	45	85[80]	85[80]	75[75]	52	120	120	120		UN-AX2, 4 x 2 or UN-AX11 x 2	TH-T100KP	67
S-2xT100	MSO-2xT100KP	30[22]	55[45]	55[45]	55	105[100]	105[93]	85[75]	65	150	150	150			TH-T65KP	15 to 54
S-2xN125	MSO-2xN125KP	37[30]	60[60]	60[60]	60	125[125]	120[120]	90[90]	70	150	150	150			TH-T100KP	67, 82
S-2xN150	MSO-2xN150KP	45[37]	75[75]	90[90]	90	150[150]	150[150]	140[140]	100	200	200	200			TH-N120KP (TA)	42 to 125
S-2xN180	MSO-2xN180KP	55[45]	90[90]	110[110]	110	180[180]	180[180]	180[180]	120	260	260	260			TH-N220KPRH	82 to 150
S-2xN220	MSO-2xN220KP	75[55]	132[110]	132[132]	132	250[220]	250[220]	200[200]	150	260	260	260	3a3b x 2	—	TH-N400KPRH	105 to 250
S-2xN300	MSO-2xN300KP	90[75]	160[150]	160[160]	200	300[300]	300[300]	250[250]	220	350	350	350			TH-N400KPRH	105 to 330
S-2xN400	MSO-2xN400KP	125[110]	220[200]	225[200]	250	400[400]	400[400]	350[350]	300	450	450	450				
S-2xN600	—	190[160]	330[300]	330[300]	330	630[630]	630[630]	500[500]	420	660	660	660	4a4b x 2	—	TH-N600KP (Note 5)	250 to 500
S-2xN800	—	220[200]	440[400]	500[400]	500	800[800]	800[800]	720[720]	630	800	800	800				250 to 660

Note 1. The value in parentheses for the rated operating current is applicable in the case of magnetic contactors.

Note 2. Enclosed type magnetic starters are of MS-2x□ type. T10, T12, T20, T25, T32 and N600, N800 types are outside production range. It should be noted that auxiliary contact units cannot be additionally installed to enclosed types.

Note 3. MS-2 x T21 types with 200 to 220 V ratings are 3.7 kW, in accordance with the Electrical Appliance and Material Safety Law.

Note 4. Enclosed type heater designation 67A uses a thermal overload relay dedicated for enclosed types.

Note 5. Please use TH-N600 in combination with a separately sold current transformer (Mitsubishi CW-□).

Note 6. Refer to page 51 for information regarding application to resistive loads and capacitive loads.

Note 7. The main contact minimum operating voltage and current differ depending on the allowable fault rate. Refer to page 42 for details.

Note 8. The +2b on the auxiliary contact arrangement of reversible T10, T12 and T20 types indicates the break contact of the integrated UT-ML20 interlock unit. There is no need to specify when ordering.

Note 9. Auxiliary contact arrangements are displayed by twos, in a contact arrangement combined with two magnetic contactors. For standard contact arrangements there is no need to specify when ordering; however, please specify a matching contact arrangement for 2 units if for a special configuration. <Example> 1b x 2 + 2b: 2B, 2a x 2 + 2b: 4A

Note 10. "BC" in the model name refers to "wiring streamlining terminal".

Note 11. MSO-2xT80CW heater designation 67A is not manufactured.

Note 12. MSO-2xT□ and MSO-2xN□ types can also be manufactured.

● Connecting Conductor Included

Standard reversible magnetic contactors do not have a connecting conductor installed on the main circuit; however, products with connecting conductors (3-pole) on the main circuit can be manufactured. The 4 types below are available. (For information on whether an additional thermal overload relay can be connected, refer to page 216.)

- (1) Mountable on Both Power/Load Side ... For Reversing Operation : S-2xT□SD, S-2xN□SD
- (2) Mountable Only on Power Side (3-Pole In-Phase) ... For 2 Load Circuits : S-2xT□SG, S-2xN□SG
- (3) Mountable Only on Load Side (3-Pole In-Phase) ... For 2 Power Systems : S-2xT□SX, S-2xN□SX
- (4) Mountable Only on Load Side (Reverse Phase Switchable) : S-2xT□SF, S-2xN□SF

Note 1. If a connecting conductor is required, refer to page 216 to order a main circuit conductor kit.

● Connecting Conductor Wiring Diagram

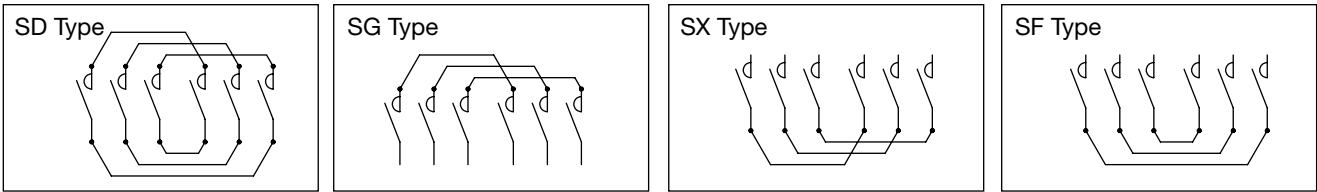

● Structure/Operation

● Structure

- (1) MSO-2 × T□, S-2 × T□ and MSO-2 × N□ types have the same mounting pitch as S-2 × N□ types.
- (2) Reversible MSO/S-2xT10 to T25 types can be mounted to IEC 35 mm rails as-is, while T35 to T80 types can be mounted by removing the mounting plate.

● Operation

(1) Open State (Fig. 1, 2(a), 3(a))

When both the left and right contactors are in the OFF state, the lever tip is retained in the open state via the return spring.

(2) Closed State (Fig. 2(b) and Fig. 3(b))

When the contactor of one side is energized (closed), the cross bar causes the lever pin (or lever system) to be pushed downward, rotating the interlock lever so that the lever tips cross each other.

When this happens, even if an energizing operation is attempted on the other contactor, as the lever tips are crossed over the operation will be prevented.

(3) Opening

When the energizing current to a contact on one side is halted, the cross bar returns to its original state via the contactor tripping spring. This action of the cross bar raises the interlock lever with the help of the return spring, returning the interlock lever to its correct position.

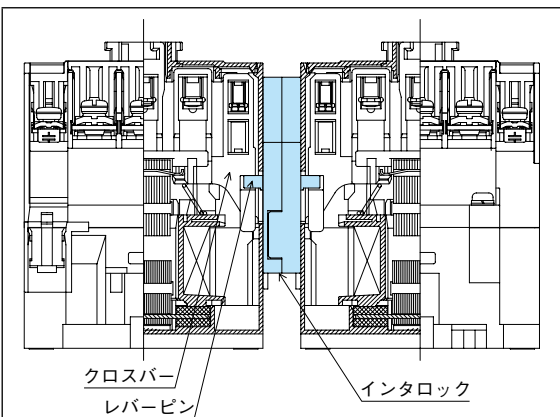

Fig. 1. Structural and Operational Diagram (T10 to T80)

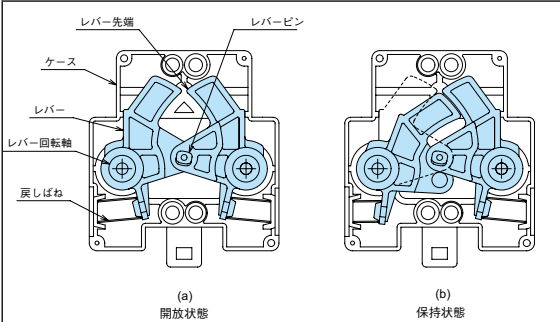

Fig. 2. Interlock Internal Structure (T10 to T80)

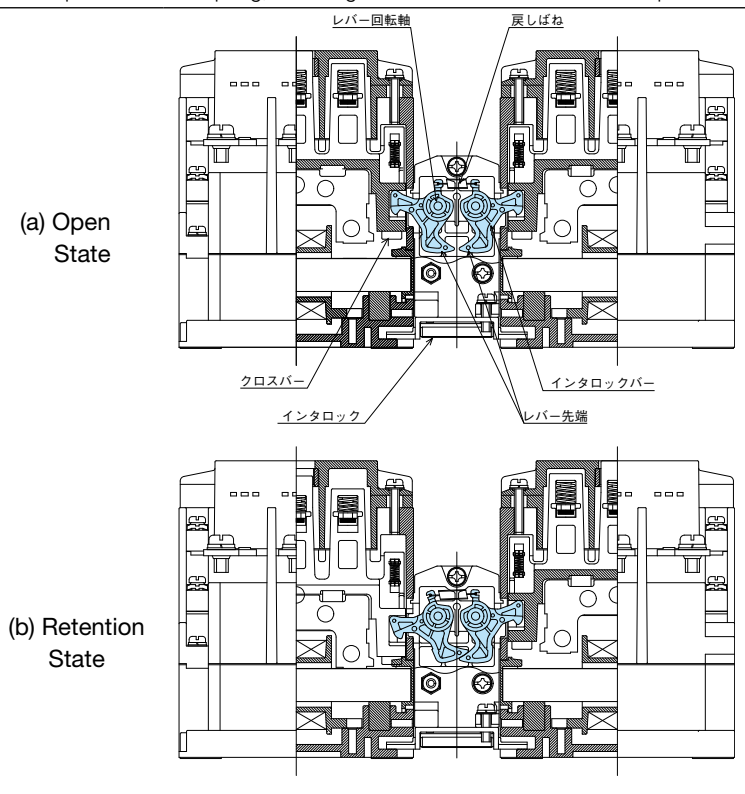

Fig. 3. Structural and Operational Diagram (T100, N125 to N400)

● Handling

- (1) Be sure to release the electrical interlock via the break contact of the left and right magnetic contactors.
- (2) The electrical interlock uses the break contact on the inner side (the mechanical interlock side).
- (3) Horizontal mounting of the product is not available.

	Item	Reference Page	Remarks
	・ Main Contact Rating	Page 39	—
	・ Auxiliary Contact Rating	Page 41	—
	・ Operation Coil	Page 43	—
	・ Properties	Page 45	—
	・ Performance	Page 46	—
	・ Outline Drawings/Contact Arrangements	Page 77	—
	・ How to Order	Page 130	—
	・ Combining with Optional Units	Page 194	—

4

MS-T/N Series Magnetic Starters/Magnetic Contactors

Note 1. The terminal numbers in parentheses for the S, SD, SL(D) auxiliary contacts in the center contact arrangement example are indicated along with the product, and represent the numbers of the old version (A Series).

N125

Non-Reversing

MSO-N125KP

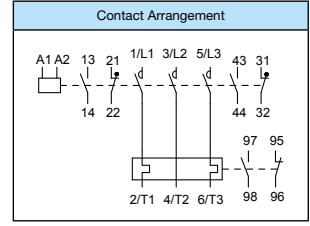
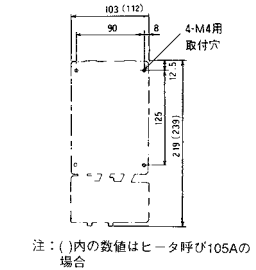
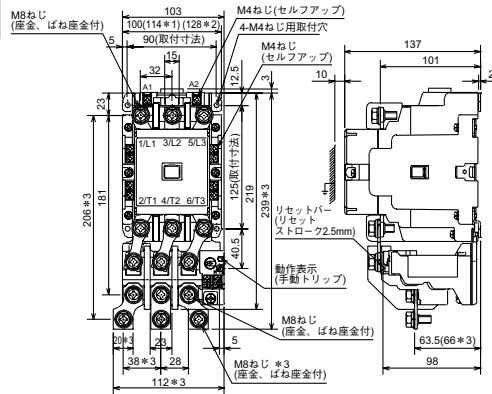
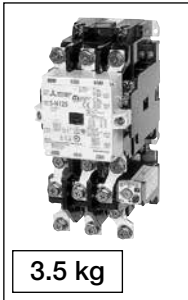

*1、*2寸法: サイドオン補助接点ユニット(UN-AX80)付・・・*1は1個、*2は2個(両側)付
*3寸法: ヒータ呼びが105Aの場合

Reversing

MSO-2xN125KP

7.0 kg

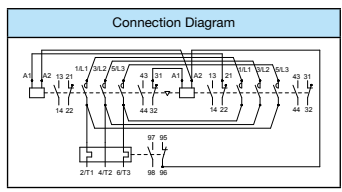
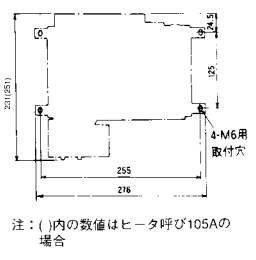
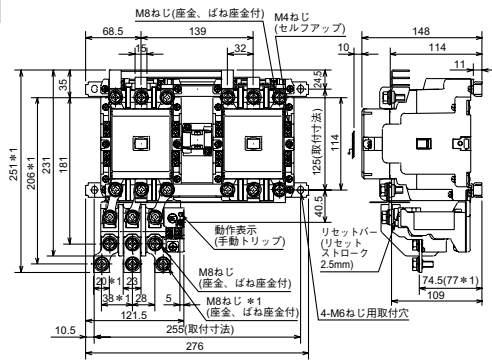

*1寸法: ヒータ呼びが105Aの場合

Non-Reversing

S-N125

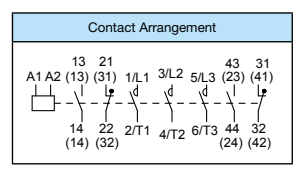
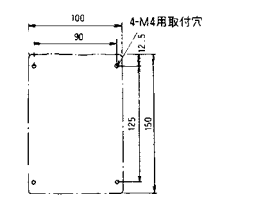
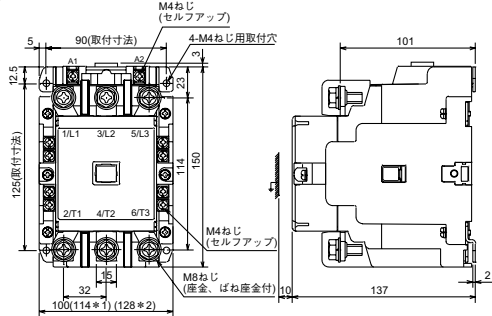
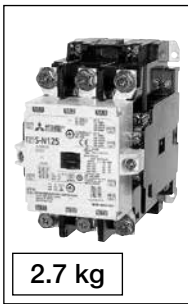

*1、*2寸法: サイドオン補助接点ユニット(UN-AX80)付・・・*1は1個、*2は2個(両側)付

Reversing

S-2xN125

6.0 kg

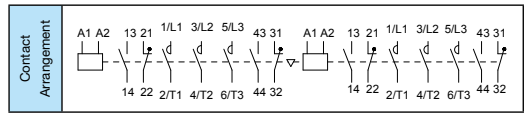
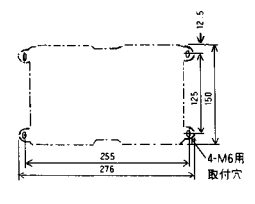
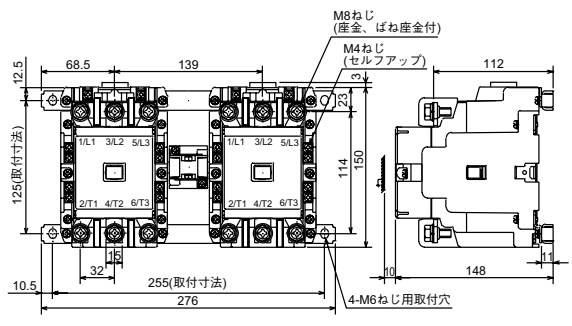

*1、*2寸法: サイドオン補助接点ユニット(UN-AX80)付・・・*1は1個、*2は2個(両側)付

Note 1. The terminal numbers in parentheses for the S, SD, SL(D) auxiliary contacts in the center contact arrangement example are indicated along with the product, and represent the numbers of the old version (A Series).

N300/N400

Non-Reversing

MSO-N300KP
MSO-N400KP

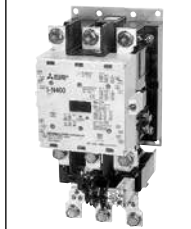

11.5 kg
12 kg

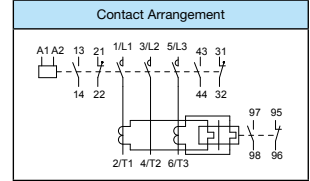
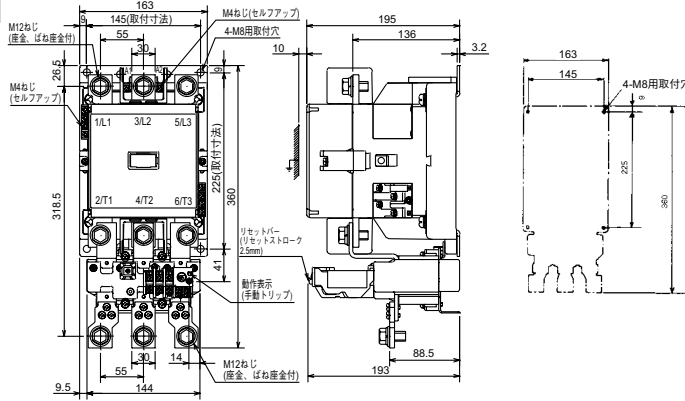

Model Name
MSO-N300KP
MSO-N400KP

Reversing

MSO-2xN300KP
MSO-2xN400KP

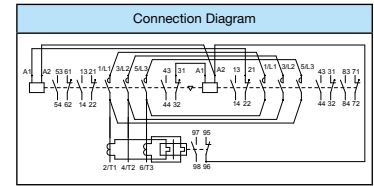
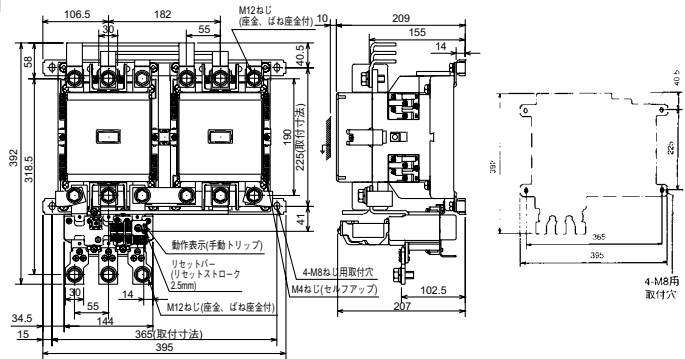

Model Name
MSO-2xN300KP
MSO-2xN400KP

Non-Reversing

S-N300
S-N400

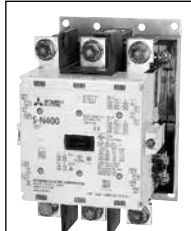

9.0 kg
9.5 kg

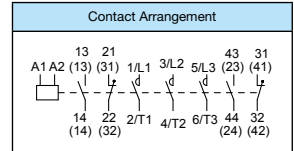
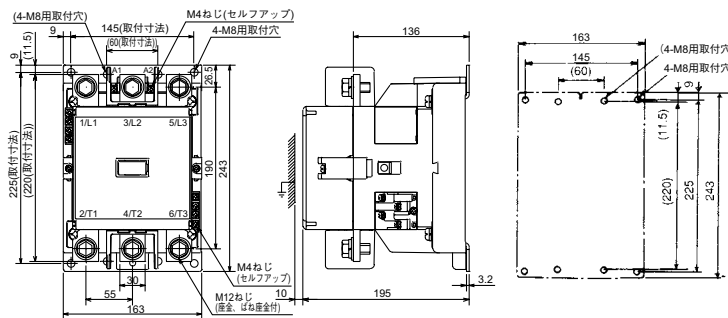

Model Name
S-N300
S-N400

Reversing

S-2xN300
S-2xN400

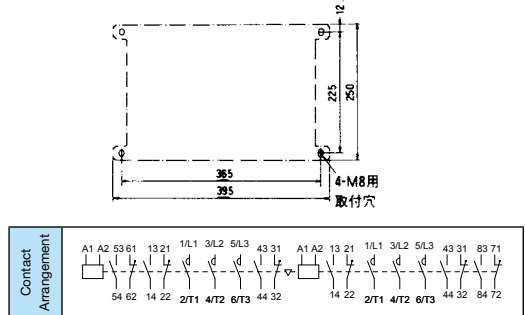
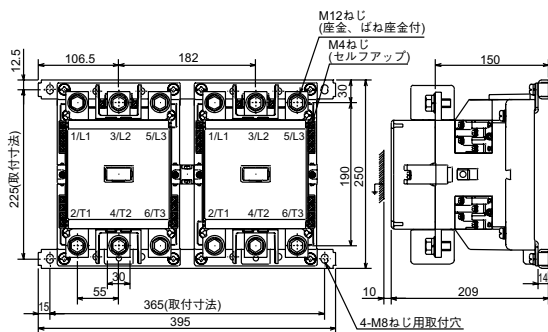

Model Name
S-2xN300
S-2xN400

N600/N800

Non-Reversing

S-N600
S-N800



24 kg

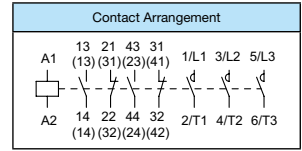
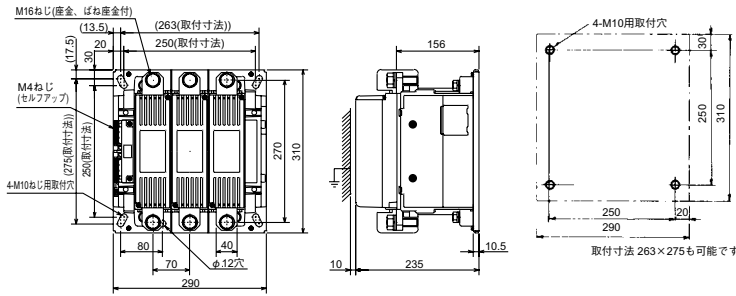

Model Name
S-N600
S-N800

Reversing

S-2 × N600
S-2 × N800

54 kg

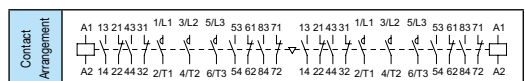
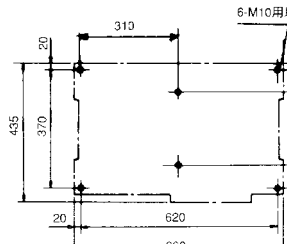
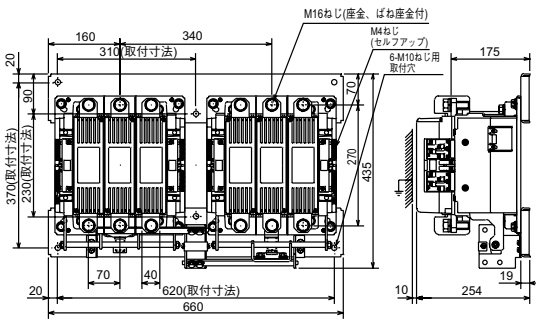

Model Name
S-2xN600
S-2xN800

● Non-Reversing Magnetic Starter (Enclosed)

Enclosure (Case): Steel
Paint Color: Munsell 5Y7/1
Protective Structure: IP20

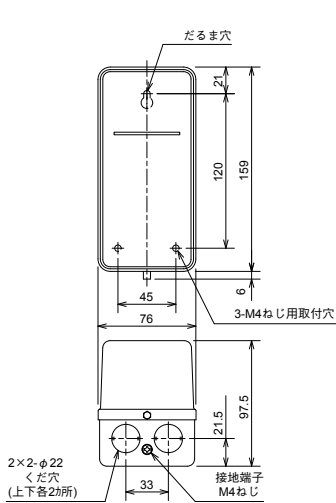

Fig 4. MS-T10KP (0.74 kg)
MS-T12KP (0.76 kg)

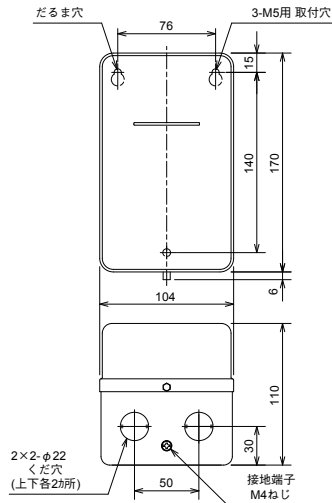

Fig 5. MS-T21KP (1.12 kg)

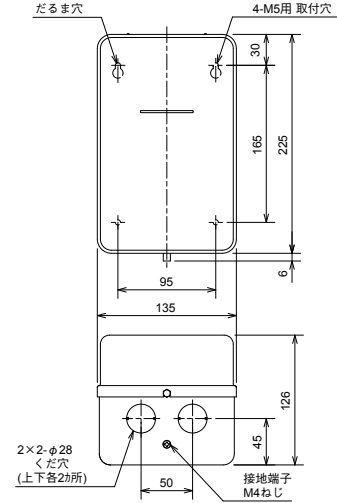

Fig 6. MS-T35KP/T50KP (1.9 kg)

Note 1. Leave 100 mm space at the bottom of the enclosure when mounting MS-T10KP to T50KP types.
Note 2. 3 rubber bushings are included for MS-T10KP to T50KP types.
Note 3. MS-T □ and MS-N □ types can also be manufactured.

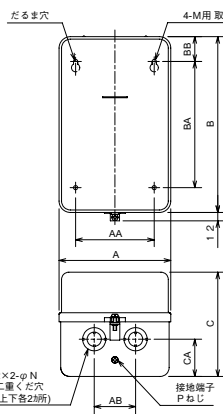

Fig 7. MS-T65KP to T100KP
MS-N125KP to N220KP

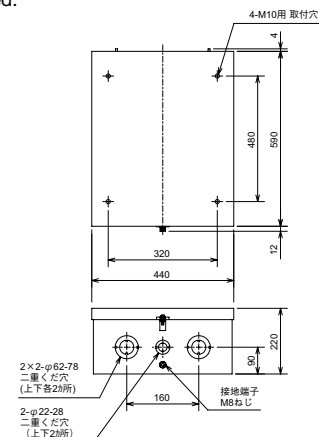
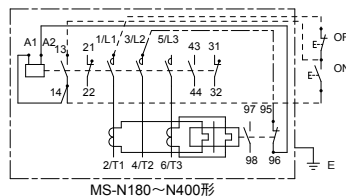
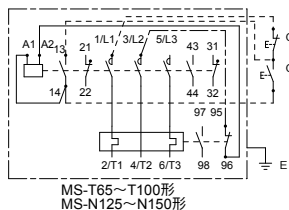
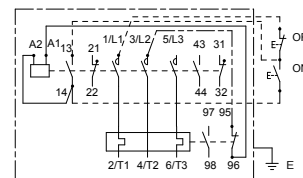
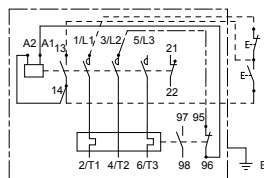
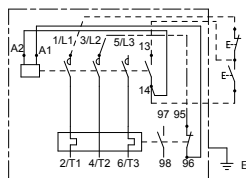

Fig 8. MS-N300KP/N400KP (27.5 kg/28 kg)

Model	Dimensions											Weight [kg]
	A	AA	AB	B	BA	BB	C	CA	M	N	P	
MS-T65KP/T80KP	160	120	80	270	220	25	145	45	M5	22 to 35	M4	2.9
MS-T100KP	190	150	100	305	260	25	163	67	M6	22 to 35	M4	4.0
MS-N125KP	230	170	90	384	330	29	190	80	M8	44 to 50	M6	8.0
MS-N150KP/N180KP/N220KP	270	200	120	484	400	44	209	85	M8	44 to 50	M6	12.8/16.2/16.2



Note 1) The figure above shows the same power supply for both the main circuit and control circuit.

The solid lines show completed wiring while the broken lines and double-dashed lines are still in need of wiring. (For the double-dashed lines, use the power supply attached to the unit)

Note 2) If the power supplies for the main circuit and control circuit differ, power wiring between the 1/L1-OFF button broken lines and the 3/L2-TH95 double-dashed lines is unnecessary, but the OFF button and TH95 terminal should be wired from the separate control circuit power supply.

Model Name	Model Name	Model Name	Model Name
MS-T10KP	MS-T65KP	MS-N125KP	MS-N400KP
MS-T12KP	MS-T80KP	MS-N150KP	
MS-T21KP	MS-T100KP	MS-N180KP	
MS-T35KP		MS-N220KP	
MS-T50KP		MS-N300KP	

● Reversing Magnetic Starters (Enclosed Type)

Enclosure (Case): Steel
 Paint Color: Munsell 5Y7/1
 Protective Structure: IP20

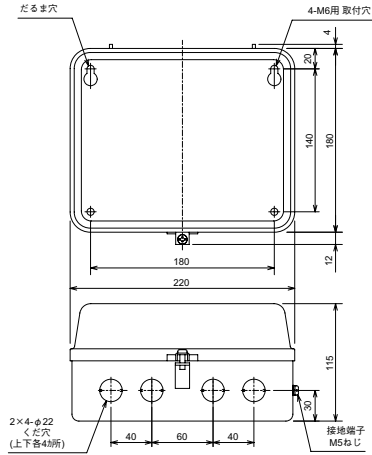

Fig. 9. MS-2xT21KP (2.0 kg)

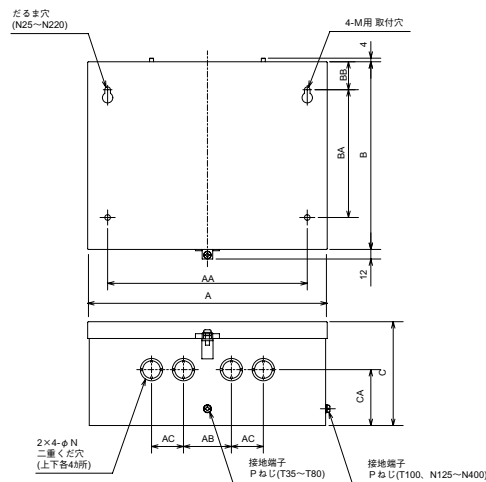
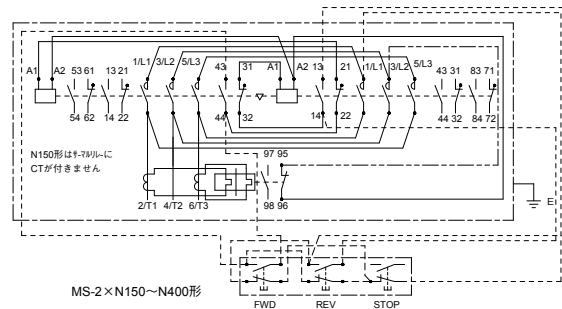
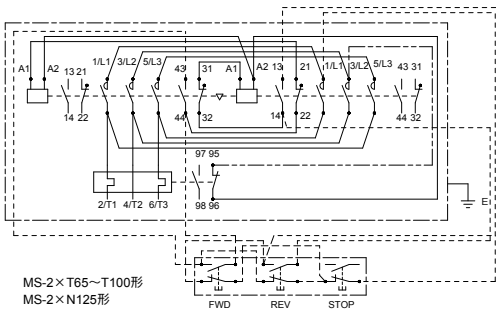
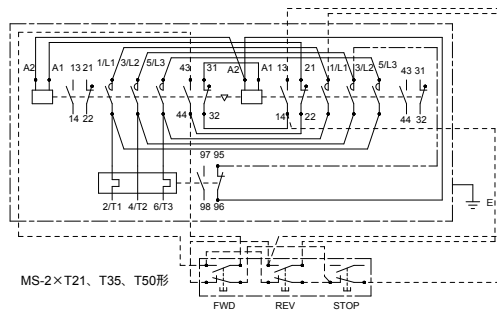

Fig. 10. MS-2xT35KP to T100KP, MS-2xN125KP to N400KP

Note 1. 3 rubber bushings are included for MS-2xT21 to T50.
 Note 2. MS-2xT □ and MS-2xN □ types can also be manufactured.

Model	Dimensions											Weight [kg]		
	A	AA	AB	AC	B	BA	BB	C	CA	M	N		O	P
MS-2xT35KP/T50KP	300	250	60	40	235	160	35	130	70	M6	22 to 28	4	M5	4.7
MS-2xT65KP/T80KP	320	270	100	60	270	240	15	140	70	M6	22 to 35	4	M6	6.6
MS-2xT100KP	410	350	140	60	330	270	35	154	87	M6	22 to 35	4	M6	10
MS-2xN125KP	440	370	120	80	424	350	39	170	94	M8	44 to 50	4	M6	15.5
MS-2xN150KP/N180KP/N220KP	520	440	160	80	524	440	44	209	90	M8	44 to 50	4	M6	20.5/28.5/28.5
MS-2xN300KP/N400KP	600	500	130	120	604	500	54	230	100	M10	62 to 78	4	M8	46/47



Note 1) The figure above shows the same power supply for both the main circuit and control circuit.
 The solid lines show completed wiring while the broken lines and double-dashed lines are still in need of wiring. (For the double-dashed lines, use the power supply attached to the unit)
 Note 2) If the power supplies for the main circuit and control circuit differ, power wiring between the 1/L1-STOP button broken lines and the 3/L2-TH95 double-dashed lines is unnecessary, but the STOP button and TH95 terminal should be wired from the separate control circuit power supply.

Model Name	Model Name	Model Name	Model Name
MS-2xT21KP	MS-2xT80KP	MS-2xN125KP	MS-2xN300KP
MS-2xT35KP	MS-2xT100KP	MS-2xN150KP	MS-2xN400KP
MS-2xT50KP		MS-2xN180KP	
MS-2xT65KP		MS-2xN220KP	

S-N38(CX)
S-N48(CX)

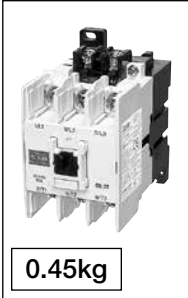

0.45kg

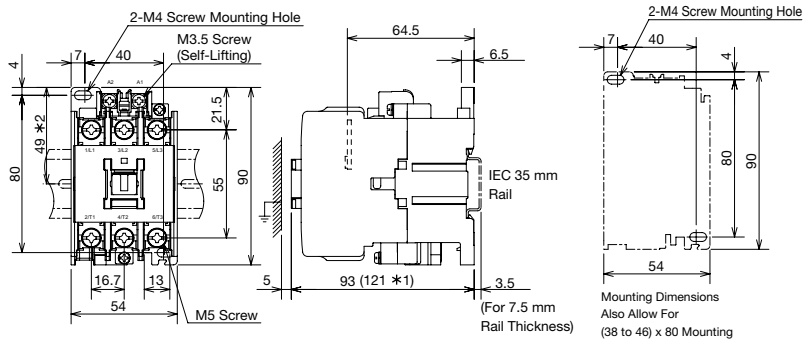

*1 Dimension: Including Head-On Auxiliary Contact Unit (UN-AX2(CX), UN-AX4(CX))
*2 Dimension: Width Dimension from Center of IEC 35 mm Rail.
Not Applicable With Side-On Auxiliary Contact Unit (UN-AX11(CX))

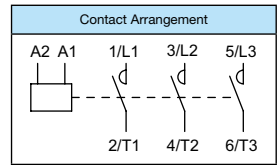

Model Name	Model Number	Model Name	Model Number
S-N38	SN03□□	S-N38CX	SN53□□
S-N48	SN03□□	S-N48CX	SN53□□

S-2xN38(CX)
S-2xN48(CX)

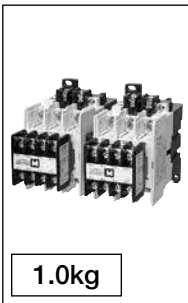

1.0kg

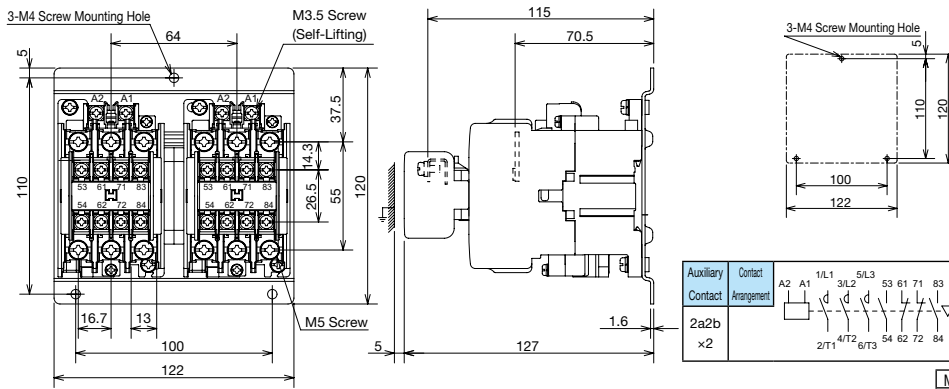

Side-On Auxiliary Contact Units (UN-AX11(CX)) Not Applicable

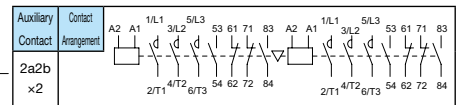

Model Name	Model Name
S-2xN38	S-2xN38CX
S-2xN48	S-2xN48CX

● MS-N Series

1. Standard (AC Operated) Magnetic Starters

■ MS-(2x)N Type (Enclosed Type)

Model Name	Motor Capacity	Main Circuit Voltage	Operation Coil Designation or Control Circuit Voltage/Frequency	(Note) Auxiliary Contact
MS-N125KP	30kW	200V	AC200V	
Refer to pages 74 and 75.	Select from page 48 or 139.	Do not apply AC voltage to the main circuit. (To distinguish it from the control circuit voltage)	Select the coil designation from page 43 or specify the control circuit voltage and frequency used.	Specify if using a special contact arrangement. Refer to page 41.

■ MSO-(2x)N Type (Open Type)

Model Name	Motor Capacity or Heater Designation (Knob Setpoint)	Main Circuit Voltage	Operation Coil Designation or Control Circuit Voltage/Frequency	(Note) Auxiliary Contact
MSO-N125KP	105A	200V	AC200V	
Refer to pages 74 and 75.	Select from page 48 or 139.	Do not apply AC voltage to the main circuit. (To distinguish it from the control circuit voltage)	Select the coil designation from page 43 or specify the control circuit voltage and frequency used.	Specify if using a special contact arrangement. Refer to page 41.

2. Standard (AC Operated) Magnetic Contactors

■ S-N Type, S-2xN Type

Model Name	Operation Coil Designation or Control Circuit Voltage and Frequency	(Note) Auxiliary Contact
S-N125	AC200V	
S-N125	AC110V 50Hz	
Refer to pages 74 and 75.	Select the coil designation from page 43 or specify the control circuit voltage and frequency used.	Specify if using a special contact arrangement. Refer to page 41.

3. DC Operated Magnetic Starters/Contactors

■ MSOD-N Type

Model Name	Motor Capacity or Heater Designation (Knob Setpoint)	Main Circuit Voltage	Operation Coil Designation	(Note) Auxiliary Contact
MSOD-N125KP	30kW	200V	DC100V	
Refer to page 91.	Select from page 48 or 139.	Do not apply AC voltage to the main circuit.	Select the coil designation from page 44.	Specify if using a special contact arrangement. Refer to page 41.

■ SD-N Type

Model Name	Operation Coil Designation	(Note) Auxiliary Contact
SD-N125	DC110V	
Refer to page 91. SD-2 x N50 is a reversing type.	Select the coil designation from page 44.	Specify if using a special contact arrangement. Refer to page 41.

4. Mechanically Latched Magnetic Starters/Contactors

■ MSOL-N Type

Model Name	Motor Capacity or Heater Designation (Knob Setpoint)	Main Circuit Voltage	Closing Coil	Tripping Coil
MSOL-N125KP	30kW	200V	MC-AC200V	MT-AC200V
MSOLD-N125KP	105A	200V	MC-DC100V	MT-DC200V
Specify "MSOLD" if using a DC operated closing coil. Refer to page 102.	Select from page 48 or 139.	Do not apply AC voltage to the main circuit. (To distinguish it from the control circuit voltage)	Select the coil designation from page 44.	

■ SL-N Type, SLD-N Type

Model Name	Closing Coil Designation	Tripping Coil Designation
SL-N125	MC-AC100V	MT-AC100V
SLD-N125	MC-DC100V	MT-DC100V
Refer to page 102. · The model name is SLD if using a DC operated closing coil.	Select the coil designation from page 44.	

■ SL-2xN Type, SLD-2xN Type

Specify using the SL-N or SL-D-N type listed above if the left and right closing coils or tripping coils have the same ratings. However, specify using the following if the left and right coils have different ratings.

Model Name	Closing Coil Designation (Left Side)	Tripping Coil Designation (Left Side)	Closing Coil Designation (Right Side)	Tripping Coil Designation (Right Side)
SLD-2xN125	MC1-DC100V	MT1-AC100V	MC2-AC100V	MT2-DC100V
Refer to page 102. · The model name is SLD if using a DC operated closing coil.	Select the coil designation from page 44.			

5. Capacitive Tripping Device

■ CTU-□□Type

Model Name	Operating Voltage Symbol
CTU-A	2
Refer to page 103. Combinable Mechanically Latched Magnetic Starters · Model names differ depending on contactor frame.	Operating Voltage is AC100V or AC200V 1: AC100V 2: AC200V

6. Delay Open Magnetic Starters/Contactors

MSO-N DLKP, S-N DL Type

Model Name	Main Circuit Specifications	Operation Coils
MSO-N150DLKP S-N400DL	▲ 125A ▲ 200V ▲ 200V	▲ AC200V ▲ AC200V
Specify from page 111.	Specify the rated voltages of the thermal overload relay heater designation and main circuit. Be sure to specify the rated voltage as there are strict criteria for the internal wiring of magnetic contactors.	The operation coil designation is available in AC100V and AC200V.

7. Magnetic Starters with Delay Trip Thermal Overload Relays

MSO-N KPSR Type

Model Name	Motor Capacity or Heater Designation (Knob Setpoint)	Main Circuit Voltage	Operation Coil Designation or Control Circuit Voltage/Frequency	(Note) Auxiliary Contact
MSO-N125KPSR	▲ 30kW	▲ 200V	▲ AC200V	
Specify from page 114.	Select from page 48 or 139.	Do not apply AC voltage to the main circuit.	Select the coil designation from page 43 or specify the control circuit voltage and frequency used.	Specify if using a special contact arrangement. Refer to page 41.

8. Main Circuit 3-Pole Magnetic Contactors

S-N Type, S-2xN Type

Model Name	Operation Coil Designation or Control Circuit Voltage and Frequency
S-N48	▲ AC200V
Specify from page 127	Select the coil designation from page 43 or specify the control circuit voltage and frequency used.