

2.1 Model List

Frame			T10	T12	T20	T21	T25	T32	T35	T50	
Applicable standard			JIS C8201-4-1, IEC60947-4-1, EN60947-4-1, GB14048.4								
Model Name	Magnetic Contactors (Without Thermal Overload Relay, Open Type)	Non-Reversing	S-T10	S-T12	S-T20	S-T21	S-T25	S-T32	S-T35	S-T50	
		Reversing	S-2 x T10	S-2 x T12	S-2 x T20	S-2 x T21	S-2 x T25	S-2 x T32	S-2 x T35	S-2 x T50	
	Magnetic Starters (With standard 2-element, With Thermal Overload Relay)	Enclosed Type	Non-Reversing	MS-T10	MS-T12	—	MS-T21	—	—	MS-T35	MS-T50
			Reversing	—	—	—	MS-2 x T21	—	—	MS-2 x T35	MS-2 x T50
		Open Type	Non-Reversing	MSO-T10	MSO-T12	MSO-T20	MSO-T21	MSO-T25	—	MSO-T35	MSO-T50
			Reversing	MSO-2 x T10	MSO-2 x T12	MSO-2 x T20	MSO-2 x T21	MSO-2 x T25	—	MSO-2 x T35	MSO-2 x T50
	Combined Thermal Overload Relays			TH-T18			TH-T25			TH-T25 / T50	TH-T25 / T50
	Magnetic Starters With 3-element type Thermal Overload Relays	Enclosed Type	Non-Reversing	MS-T10KP	MS-T12KP	—	MS-T21KP	—	—	MS-T35KP	MS-T50KP
			Reversing	—	—	—	MS-2 x T21KP	—	—	MS-2 x T35KP	MS-2 x T50KP
		Open Type	Non-Reversing	MSO-T10KP	MSO-T12KP	MSO-T20KP	MSO-T21KP	MSO-T25KP	—	MSO-T35KP	MSO-T50KP
Reversing			MSO-2 x T10KP	MSO-2 x T12KP	MSO-2 x T20KP	MSO-2 x T21KP	MSO-2 x T25KP	—	MSO-2 x T35KP	MSO-2 x T50KP	
Combined Thermal Overload Relays			TH-T18KP			TH-T25KP			TH-T25 / T50KP	TH-T25 / T50KP	
Main contact rating	Rated Insulation Voltage [V]		690								
	Rated Impulse Withstand Voltage [kV]		6								
	Rated Frequency [Hz]		50/60								
	Pollution Degree		3								
	Rated operational current / power Category AC-3 (Note 1) (Three-phase squirrel-cage motor load standard responsibility) (Note 2) [kW/A]	AC220 to 240V	2.5/11 [2.2/11]	3.5/13 [2.7/13]	4.5/18 [3.7/18]	5.5/25 [4/20]	7.5/30 [26]	5.5/28	7.5/32 [7.5/32]	11/40 [7.5/35]	15/55 [50] [11/50]
		AC380 to 440V	4/9 [2.7/7]	5.5/12 [4/9]	7.5/18 [7.5/18]	11/23 [7.5/20]	15/30 [26]	11/25	15/32 [15/32]	18.5/40 [15/32]	22/50 [22/48]
		AC500V	4/7 [2.7/6]	5.5/9 [5.5/9]	7.5/17 [7.5/17]	11/17 [7.5/17]	15/24 [11/20]	11/24	15/24 [11/20]	18.5/32 [15/26]	25/38 [22/38]
		AC690V	4/5	5.5/7	7.5/9	7.5/9	11/12	11/12	11/12	15/17	22/26
	Rated operational current / power Category AC-4 (Three-phase squirrel-cage motor load inching responsibility) [kW/A]	AC220 to 240V	1.5/8	2.2/11	3.7/18	4.5/20	5.5/26	5.5/26	5.5/26	7.5/35	
		AC380 to 440V	2.2/6	4/9	5.5/13	7.5/17	11/24	11/24	11/24	15/32	
AC500V		2.7/6	5.5/9	5.5/10	7.5/12	7.5/13	11/17	15/24	15/24		
Rated operational current / power Category AC-1 (Resistance, heater load)	AC100 to 240V	20			32			60			
	AC380 to 440V	11	13	13	32	32	60	60	80		
	AC500 to 550V	8	11	13	32	32	60	60	80		
Conventional Free Air Thermal Current I _{th} [A]		20			32			60			
Auxiliary contact rating	Contact Arrangement	Standard Accessory (Note 7)	Non-Reversing	1a	1a1b	2a2b	—	2a2b	2a2b		
		Reversing (Note 8, Note 9)	1a x 2 + 2b	1a1b x 2 + 2b	2a2b x 2	2a2b x 2	2a2b x 2	2a2b x 2			
	Max. number of additional options (Note 11)	Non-Reversing	1 for UT-AX2/4, 2 for UT-AX11								
		Reversing (Note 8, Note 9)	2 for any UT-AX2/4/11				—	2 for any UT-AX2/4/11			
	Rated Operating Current (Category AC-15: Alternating current coil load) [A]		AC120V	6	6	6	6	6	6	6	
Rated Operational Current (Category DC-13 : Direct current coil load)		DC24V	3	3	3	3	3	3	3		
Conventional Free Air Thermal Current I _{th} [A]		DC110V	0.6								
Performance	Mechanical Durability [x 10000]		1000								
	Electrical Durability (Note 5) [Ten thousand times]	Category AC-3	200 (Note 5, 6)								
		Category AC-4	3 (Note 5)								
		Category AC-1	50								
	Switching Frequency [Times/Hour]	Category AC-3	1800								1200
Category AC-4		300									
Category AC-1		1200									
Characteristic	Coil consumption (Note7) [VA]		Sealed	7	7	7	4.5	10	10		
	Power Consumption (Note 7) [W]		Inrush	45	75	75	55	110	110		
Outside Dimensions	Magnetic Contactors (without Thermal Overload Relays) (Width x Height x Depth) [mm]		Non-Reversing	36 x 75 x 78	44 x 75 x 78	63 x 81 x 81	43 x 81 x 81	75 x 89 x 91	75 x 89 x 91		
			Reversing	82 x 85 x 78	98 x 85 x 78	136 x 81 x 81	96 x 81 x 111	160 x 114 x 97	160 x 114 x 97		
	Open Type Magnetic Starters (Width x Height x Depth) [mm]		Non-Reversing	46 x 115 x 79			63 x 128 x 82	—	75 x 157.5 x 91		
			Reversing	90.5 x 125 x 79	98.5 x 125 x 79	136 x 138 x 82	—	160 x 179 x 97			
	Enclosed Magnetic Starters (Width x Height x Depth) [mm]		Non-Reversing	76 x 165 x 97.5			104 x 176 x 110	—	135 x 231 x 126		
			Reversing	—			220 x 192 x 115	—	300 x 247 x 130		
IEC 35mm rail mounting			Possible (excluding Enclosed Magnetic Starters)								
Installable Optional Unit Model Names (Note 10)	Additional Auxiliary Contact Units		UT-AX2/AX11								
			UT-AX4								
	With Low-Level Signal Contact		—								
	(Varistor) (Note 4)		UT-SA21								
	Coil Surge Absorber Units (Note 4)		UT-SA22								
			UT-SA23								
			UT-SA25								
	DC-AC Interface		Triac Output								
			Contact Output								
			UT-SY21								
Live Part Protection Cover	For Magnetic Starters	Non-Reversing	—								
		Reversing	—								
	For Magnetic Contactors	Non-Reversing	—								
		Reversing	—								
Terminal Cover	For Magnetic Starters (Non-Reversing)	(Standard Equipment)									
	For Magnetic Contactors (Non-Reversing)	(Standard Equipment)									
Mechanical Interlock Units			UT-ML20 (Note 11)			UN-ML21					

Note 1. The figure in the square brackets indicates the rated current shown on the rating plate of the product at which the category AC-3 opening/closing durability. Note 2. The value between parentheses for the rated operating current is for the magnetic starter (with thermal overload relay). Note 3. AC operated types T10 to T50, DC operated types T12 to T50 can be manufactured with coil surge absorber (□-□SA type). The UT-SA21 type can be mounted. Note 4. T65 to N800 types have an integrated coil surge absorber rendering a coil surge absorber unit for prevention of coil switching surges unnecessary. Note 5. 1 million times for T20 class AC-3 380 V or more types for the rating in parentheses and 15,000 times for class AC-4 types. 15 thousand times for T35 to N800 class AC-4 380 V or more types. Note 6. Values are for the ratings in square brackets. The electrical durability for the current values not in parentheses varies inversely with the rough square of the current. Note 7. Mechanically latched types and delay open types have differing auxiliary contact arrangements. Refer to page 102 for details about mechanically latched types, or page 111 for delay open types.

T65	T80	T100	N125	N150	N180	N220	N300	N400	N600	N800
JIS C8201-4-1, IEC60947-4-1, EN60947-4-1, GB14048.4										
S-T65	S-T80	S-T100	S-N125	S-N150	S-N180	S-N220	S-N300	S-N400	S-N600	S-N800
S-2 x T65	S-2 x T80	S-2 x T100	S-2 x N125	S-2 x N150	S-2 x N180	S-2 x N220	S-2 x N300	S-2 x N400	S-2 x N600	S-2 x N800
MS-T65	MS-T80	MS-T100	MS-N125	MS-N150	MS-N180	MS-N220	MS-N300	MS-N400	—	—
MS-2 x T65	MS-2 x T80	MS-2 x T100	MS-2 x N125	MS-2 x N150	MS-2 x N180	MS-2 x N220	MS-2 x N300	MS-2 x N400	—	—
MSO-T65	MSO-T80	MSO-T100	MSO-N125	MSO-N150	MSO-N180	MSO-N220	MSO-N300	MSO-N400	—	—
MSO-2 x T65	MSO-2 x T80	MSO-2 x T100	MSO-2 x N125	MSO-2 x N150	MSO-2 x N180	MSO-2 x N220	MSO-2 x N300	MSO-2 x N400	—	—
TH-T65	TH-T65 / T100	TH-T65 / T100	TH-N120(TA)	TH-N120(TA)	TH-N220RH	TH-N220RH	TH-N400RH	TH-N400RH	TH-N600(+CT)	TH-N600(+CT)
MS-T65KP	MS-T80KP	MS-T100KP	MS-N125KP	MS-N150KP	MS-N180KP	MS-N220KP	MS-N300KP	MS-N400KP	—	—
MS-2 x T65KP	MS-2 x T80KP	MS-2 x T100KP	MS-2 x N125KP	MS-2 x N150KP	MS-2 x N180KP	MS-2 x N220KP	MS-2 x N300KP	MS-2 x N400KP	—	—
MSO-T65KP	MSO-T80KP	MSO-T100KP	MSO-N125KP	MSO-N150KP	MSO-N180KP	MSO-N220KP	MSO-N300KP	MSO-N400KP	—	—
MSO-2 x T65KP	MSO-2 x T80KP	MSO-2 x T100KP	MSO-2 x N125KP	MSO-2 x N150KP	MSO-2 x N180KP	MSO-2 x N220KP	MSO-2 x N300KP	MSO-2 x N400KP	—	—
TH-T65KP	TH-T65 / T100KP	TH-T65 / T100KP	TH-N120(TA)KP	TH-N120(TA)KP	TH-N220RHKP	TH-N220RHKP	TH-N400RHKP	TH-N400RHKP	TH-N600KP(+CT)	TH-N600KP(+CT)
690					690 (1000)					
6					6 (8)					
50/60										
3										
18.5/65 [15/65]	22/85 [19/80]	30/105 [22/100]	37/125 [30/125]	45/150 [37/150]	55/180 [45/180]	75/250 [55/220]	90/300 [75/300]	125/400 [110/400]	190/630 [160/630]	220/800 [200/800]
30/65 [30/65]	45/85 [37/80]	55/105 [45/93]	60/120 [60/120]	75/150 [75/150]	90/180 [90/180]	132/250 [110/220]	160/300 [150/300]	220/400 [200/400]	330/630 [300/630]	440/800 [400/800]
37/60 [30/45]	45/75 [45/75]	55/85 [45/75]	60/90 [60/90]	90/140 [90/140]	110/180 [110/180]	132/200 [132/200]	160/250 [160/250]	225/350 [200/350]	330/500 [300/500]	500/720 [400/720]
30/38	45/52	55/65	60/70	90/100	110/120	132/150	200/220	250/300	330/420	500/630
11/50	15/65	19/80	22/93	30/125	37/150	45/180	55/220	75/300	110/400	160/630
22/47	30/62	37/75	45/90	55/110	75/150	90/180	110/220	150/300	200/400	300/630
22/38	30/45	37/55	45/65	55/80	75/140	90/140	110/200	150/250	200/350	300/500
100	120	150	150	200	260	260	350	450	660	800
100	120	150	150	200	260	260	350	450	660	800
100	120	150	150	200	260	260	350	450	660	800
100	120	150	150	200	260	260	350	450	660	800
2a2b	2a2b	2a2b	2a2b	2a2b	2a2b	2a2b	2a2b	2a2b	2a2b	2a2b
2a2b x 2	2a2b x 2	2a2b x 2	2a2b x 2	3a3b x 2	3a3b x 2	3a3b x 2	3a3b x 2	3a3b x 2	4a4b x 2	4a4b x 1
1 for UT-AX2/4, 2 for UT-AX11		2 for UN-AX80			2 for UN-AX150				1 for UN-AX600	
2 for any UT-AX2/4/11		2 for UN-AX80			—	—	—	—	—	—
6	6	6	6	6	6	6	6	6	6	6
3	3	3	3	3	3	3	3	3	3	3
3		3			3				3	
0.6										
10	10	10	10	10	10	10	10	10	10	10
500										
200	100 (Note 6)							50 (Note 6)		
3 (Note 5)										
50										
1200										
300										
1200		600								
20	23	24	24	40	40	50	50	90	90	90
115	210	270	270	440	440	440	440	790	790	790
2.2	2.2	2.8	2.9	2.9	4.2	4.2	6.1	6.1	17	17
88 x 106 x 106	88 x 106 x 106	100 x 124 x 127	100 x 150 x 137	120 x 160 x 145	138 x 204 x 175	138 x 204 x 175	163 x 243 x 195	163 x 243 x 195	290 x 310 x 235	290 x 310 x 235
216 x 115 x 112	216 x 115 x 112	270 x 140 x 137	276 x 150 x 148	296 x 160 x 156	370 x 215 x 189	370 x 215 x 189	395 x 250 x 209	395 x 250 x 209	660 x 435 x 254	660 x 435 x 254
90 x 158 x 106	90 x 174.5 x 106	100 x 196 x 127	112 x 239 x 137	120 x 250 x 145	144 x 282 x 180.5	144 x 282 x 180.5	163 x 360 x 195	163 x 360 x 195	—	—
216 x 169 x 112	216 x 185.5 x 112	270 x 213 x 137	276 x 251 x 148	296 x 276 x 156	370 x 304 x 194.5	370 x 304 x 194.5	395 x 392 x 209	395 x 392 x 209	—	—
160 x 282 x 145	190 x 317 x 163	230 x 396 x 190	—	—	270 x 496 x 209	—	—	—	—	—
320 x 282 x 140	410 x 347 x 154	440 x 436 x 170	—	—	520 x 536 x 209	—	600 x 616 x 230	—	—	—
Possible (excluding Enclosed Magnetic Starters)										
UN-AX2/AX11		UN-AX80			UN-AX150				UN-AX600	
UN-AX4		—			—				—	
UN-LL22		—			—				—	
—		—			—				—	
—		—			—				—	
—		—			—				—	
UN-SY31		—			—				—	
UN-SY32		—			—				—	
UN-CZ500 + UN-CZ501		UN-CZ800+ UN-CZ801	UN-CZ1250+ UN-CZ1251	UN-CZ1500+ UN-CZ1501	UN-CZ2200 + UN-CZ2201		UN-CZ3000 + UN-CZ3001		—	—
UN-CZ504		UN-CZ804	UN-CZ1254	UN-CZ1504	UN-CZ2204		UN-CZ3004		—	—
UN-CZ500 x 2		UN-CZ800 x 2	UN-CZ1250 x 2	UN-CZ1500 x 2	UN-CZ2200 x 2		UN-CZ3000 x 2		—	—
UN-CZ502		UN-CZ802	UN-CZ1252	UN-CZ1502	UN-CZ2202		UN-CZ3002		—	—
UT-CW800 + UT-CW655		—			—				—	
UT-CW800		—			—				—	
UN-ML21		UN-ML80		UN-ML150	UN-ML220					

Note 8. The +2b on the auxiliary contact arrangement of reversible T10 to T20 types indicates the break contact of the integrated UT-ML20 interlock unit. There is no need to specify when ordering.

Note 9. Auxiliary contact arrangements for reversible types are displayed by twos, in a contact arrangement combined with two magnetic contactors. For standard contact arrangements there is no need to specify the ordering; however, please specify a matching contact arrangement for 2 units if for a special configuration. <Example> For 1b x 2 + 2b: 2B

Note 10. Because there are products that cannot be mounted, please refer to combination details on page 192 when applying optional products.

Note 11. Not applicable to AC operated types produced before March, 2019.

2.2 Manufacturing Range List

● Non-Reversible Type

Frame		T10	T12	T20	T21	T25	T32	T35	T50	T65	T80	T100	N125	N150	N180	N220	N300	N400	N600	N800					
Category AC-3	220V	2.5	3.5	4.5	5.5	7.5	7.5	11	15	18.5	22	30	37	45	55	75	90	125	190	220					
Rated Capacity [kW]	440V	4	5.5	7.5	11	15	15	18.5	22	30	45	55	60	75	90	132	160	220	330	440					
Auxiliary Contact (Note 6)	Standard	1a	1a1b	1a1b	←2a2b→		←2a2b→																		
	Special	1b	2a (Note 8)	2a (Note 8)	—	—	—	—	—	—	—	—	—	—	—	—	—	—	—	—	—				
Model Name																									
Magnetic Starters	Enclosed	Standard Specifications	MS-□	○	○	—	○	—	—	○	○	○	○	○	○	○	○	○	○	○	○	—	—		
		With Push-Button	MS-□PM	○	○	—	○	—	—	○	○	○	○	○	—	—	—	—	—	—	—	—	—	—	
		3-Element (2E) Thermal	MS-□KP	○	○	—	○	—	—	○	○	○	○	○	○	○	○	○	○	○	○	○	○	—	—
		Open Time Quick Motion Type	MS-□QM	—	—	—	—	—	—	—	○	○	○	○	○	○	○	○	○	○	○	○	○	—	—
	Open Type	Standard Specifications	MSO-□	○	○	○	○	○	—	○	○	○	○	○	○	○	○	○	○	○	○	○	○	—	—
			MSOD-□	—	○	○	○	—	—	○	○	○	○	○	○	○	○	—	○	○	○	○	○	—	—
		3-Element (2E) Thermal	MSO-□KP	○	○	○	○	○	—	○	○	○	○	○	○	○	○	○	○	○	○	○	○	—	—
			MSOD-□KP	—	○	○	○	—	—	○	○	○	○	○	○	○	○	—	○	○	○	○	○	—	—
		With Saturable Reactor	MSO-□SR	○	○	○	○	○	—	○	○	○	○	○	○	○	○	○	○	○	○	○	○	—	—
			MSOD-□SR	—	○	○	○	—	—	○	○	○	○	○	○	○	○	—	○	○	○	○	○	—	—
		With 3-Element (2E) Thermal Saturable Reactor	MSO-□KPSR	—	—	—	○	○	—	○	○	○	○	○	○	○	○	○	○	○	○	○	○	—	—
			MSOD-□KPSR	—	—	—	○	—	—	○	○	○	○	○	○	○	—	○	○	○	○	○	○	—	—
		2-Element Quick-acting Characteristics Thermal	MSO-□FS	—	—	—	○	○	—	○	○	○	○	○	—	—	—	—	—	—	—	—	—	—	—
			MSOD-□FS	—	—	—	○	—	—	○	○	○	○	○	—	—	—	—	—	—	—	—	—	—	—
		3-Element (2E) Quick-acting Characteristics Thermal	MSO-□FSKP	○	○	○	○	○	—	○	○	○	○	○	—	—	—	—	—	—	—	—	—	—	—
			MSOD-□FSKP	—	○	○	○	—	—	○	○	○	○	○	—	—	—	—	—	—	—	—	—	—	—
		Open Time Quick Motion Type	MSO-□QM	—	—	—	—	—	—	—	—	○	○	○	○	○	○	○	○	○	○	○	○	—	—
			MSOD-□QM	—	—	—	—	—	—	—	—	○	○	○	○	○	○	○	○	○	○	○	○	—	—
		Surge Absorber Mounted Type	MSO-□SA	○	○	○	○	○	—	○	○	—	—	—	—	—	—	—	—	—	—	—	—	—	—
			MSOD-□SA	—	○	○	○	—	—	○	○	—	—	—	—	—	—	—	—	—	—	—	—	—	—
	Wiring Streamlining Terminal	MSO-□BC	○	○	○	○	○	—	○	○	—	—	—	—	—	—	—	—	—	—	—	—	—	—	
		MSOD-□BC	—	○	○	○	—	—	○	○	—	—	—	—	—	—	—	—	—	—	—	—	—	—	
	Anticorrosion Treatment	MSO-□YS	○	○	○	○	○	—	○	○	○	○	○	○	○	○	○	○	○	○	○	○	—	—	
		MSOD-□YS	—	○	○	○	—	—	○	○	○	○	○	○	○	—	○	○	○	○	○	○	—	—	
	Delay Open Type	MSO-□DL	—	○	—	○	—	—	○	○	○	○	○	—	○	—	○	○	○	○	○	○	—	—	
		MSOD-□DL	—	○	—	○	—	—	○	○	○	○	○	—	○	—	○	○	○	○	○	○	—	—	
	Mechanically Latched Type	MSOL-□	—	—	—	○	—	—	○	○	○	○	○	○	○	—	○	○	○	○	○	○	—	—	
		MSOLD-□	—	—	—	○	—	—	○	○	○	○	○	○	○	—	○	○	○	○	○	○	—	—	
With Terminal Cover	MSO-□CW	—	—	—	—	—	—	—	—	○	○	○	○	○	○	○	○	○	○	○	○	○	○		
	MSOD-□CW	—	—	—	—	—	—	—	—	○	○	○	○	○	○	○	○	○	○	○	○	○	○		
Magnetic Contactors	Open Type	Standard Specifications	S-□	○	○	○	○	○	○	○	○	○	○	○	○	○	○	○	○	○	○	○	○	○	
			SD-□	—	○	○	○	—	○	○	○	○	○	○	○	○	○	—	○	○	○	○	○	○	
		Surge Absorber Mounted Type	S-□SA(Note3)	○	○	○	○	○	○	○	○	—	—	—	—	—	—	—	—	—	—	—	—	—	—
			SD-□SA	—	○	○	○	—	○	○	○	—	—	—	—	—	—	—	—	—	—	—	—	—	—
		Anticorrosion Treatment	S-□YS	—	—	—	—	—	—	○	○	○	○	○	○	○	○	○	○	○	○	○	○	○	○
			S-□QM	—	—	—	—	—	—	—	—	○	○	○	○	○	○	○	○	○	○	○	○	—	—
		Wiring Streamlining Terminal	S-□BC	○	○	○	○	○	○	○	○	—	—	—	—	—	—	—	—	—	—	—	—	—	—
			SD-□BC	—	○	○	○	—	○	○	○	—	—	—	—	—	—	—	—	—	—	—	—	—	—
		With Spring Clamp Terminals	S-□SQ	—	○	○	—	—	—	—	—	—	—	—	—	—	—	—	—	—	—	—	—	—	—
			SD-□SQ	—	○	○	—	—	—	—	—	—	—	—	—	—	—	—	—	—	—	—	—	—	—
		With Terminal Cover	S-□CW	—	—	—	—	—	—	—	—	○	○	○	○	○	○	○	○	○	○	○	○	○	○
			SD-□CW	—	—	—	—	—	—	—	—	○	○	○	○	○	○	○	○	○	○	○	○	○	○
Delay Open Type	S-□DL	—	○	—	○	—	—	○	○	○	○	○	—	○	—	○	○	○	○	○	○	—	—		
	SD-□DL	—	○	—	○	—	—	○	○	○	○	○	—	○	—	○	○	○	○	○	○	—	—		
Mechanically Latched Type	SL-□	—	—	—	○	—	—	○	○	○	○	○	○	○	—	○	○	○	○	○	○	○	○		
	SLD-□	—	—	—	○	—	—	○	○	○	○	○	○	○	—	○	○	○	○	○	○	○	○		

● Reversible Type

Frame		2 x T10	2 x T12	2 x T20	2 x T21	2 x T25	2 x T32	2 x T35	2 x T50	2 x T65	2 x T80	2 x T100	2 x N125	2 x N150	2 x N180	2 x N220	2 x N300	2 x N400	2 x N600	2 x N800		
Category AC-3	220V	2.5	3.5	4.5	5.5	7.5	7.5	11	15	18.5	22	30	37	45	55	75	90	125	190	220		
	Rated Capacity [kW]	440V	4	5.5	7.5	11	15	15	18.5	22	30	45	55	60	75	90	132	160	220	330	440	
Auxiliary Contact (Note 4 to Note 6)	Standard	(1a x 2) + 2b	(1a1b x 2) + 2b	2a2b x 2										3a3b x 2					4a4b x 2			
	Special	(1b x 2) + 2b	(2a x 2) + 2b	-	-	-	-	-	-	-	-	-	-	-	-	-	-	-	-	-	-	
Model	Standard Specifications	MS-□	○	○	○	○	○	○	○	○	○	○	○	○	○	○	○	○	○	○	○	
Magnetic Starters	3-Element (2E) Thermal	MS-□KP	○	○	○	○	○	○	○	○	○	○	○	○	○	○	○	○	○	○	○	
	Standard Specifications	MSO-□	◎	◎	◎	◎	◎	◎	◎	◎	◎	◎	◎	◎	◎	◎	◎	◎	◎	◎	◎	
	3-Element (2E) Thermal	MSO-□KP	○	○	○	○	○	○	○	○	○	○	○	○	○	○	○	○	○	○	○	○
		MSOD-□KP	○	○	○	○	○	○	○	○	○	○	○	○	○	○	○	○	○	○	○	○
	With Saturable Reactor	MSO-□SR	○	○	○	○	○	○	○	○	○	○	○	○	○	○	○	○	○	○	○	○
		MSOD-□SR	○	○	○	○	○	○	○	○	○	○	○	○	○	○	○	○	○	○	○	○
	With 3-Element (2E) Thermal Saturable Reactor	MSO-□KPSR	○	○	○	○	○	○	○	○	○	○	○	○	○	○	○	○	○	○	○	○
		MSOD-□KPSR	○	○	○	○	○	○	○	○	○	○	○	○	○	○	○	○	○	○	○	○
	2-Element Quick-acting Characteristics Thermal	MSO-□FS	○	○	○	○	○	○	○	○	○	○	○	○	○	○	○	○	○	○	○	○
		MSOD-□FS	○	○	○	○	○	○	○	○	○	○	○	○	○	○	○	○	○	○	○	○
	3-Element (2E) Quick-acting Characteristics Thermal	MSO-□FSKP	○	○	○	○	○	○	○	○	○	○	○	○	○	○	○	○	○	○	○	○
		MSOD-□FSKP	○	○	○	○	○	○	○	○	○	○	○	○	○	○	○	○	○	○	○	○
	Surge Absorber Mounted Type	MSO-□SA	○	○	○	○	○	○	○	○	○	○	○	○	○	○	○	○	○	○	○	○
		MSOD-□SA	○	○	○	○	○	○	○	○	○	○	○	○	○	○	○	○	○	○	○	○
	Wiring Streamlining Terminal	MSO-□BC	○	○	○	○	○	○	○	○	○	○	○	○	○	○	○	○	○	○	○	○
		MSOD-□BC	○	○	○	○	○	○	○	○	○	○	○	○	○	○	○	○	○	○	○	○
	With Terminal Cover	MSO-□CW	○	○	○	○	○	○	○	○	○	○	○	○	○	○	○	○	○	○	○	○
		MSOD-□CW	○	○	○	○	○	○	○	○	○	○	○	○	○	○	○	○	○	○	○	○
	Anticorrosion Treatment	MSO-□YS	○	○	○	○	○	○	○	○	○	○	○	○	○	○	○	○	○	○	○	○
		MSOD-□YS	○	○	○	○	○	○	○	○	○	○	○	○	○	○	○	○	○	○	○	○
Mechanically Latched Type	MSOL-□	○	○	○	○	○	○	○	○	○	○	○	○	○	○	○	○	○	○	○	○	
	MSOLD-□	○	○	○	○	○	○	○	○	○	○	○	○	○	○	○	○	○	○	○	○	
Magnetic Contactors	Standard Specifications	S-□	◎	◎	◎	◎	◎	◎	◎	◎	◎	◎	◎	◎	◎	◎	◎	◎	◎	◎	◎	
	Surge Absorber Mounted Type	SD-□	○	○	○	○	○	○	○	○	○	○	○	○	○	○	○	○	○	○	○	○
		S-□SA(Note 3)	○	○	○	○	○	○	○	○	○	○	○	○	○	○	○	○	○	○	○	○
	Anticorrosion Treatment	SD-□SA	○	○	○	○	○	○	○	○	○	○	○	○	○	○	○	○	○	○	○	○
		S-□YS	○	○	○	○	○	○	○	○	○	○	○	○	○	○	○	○	○	○	○	○
	Wiring Streamlining Terminal	S-□BC	○	○	○	○	○	○	○	○	○	○	○	○	○	○	○	○	○	○	○	○
		SD-□BC	○	○	○	○	○	○	○	○	○	○	○	○	○	○	○	○	○	○	○	○
	With Terminal Cover	S-□CW	○	○	○	○	○	○	○	○	○	○	○	○	○	○	○	○	○	○	○	○
		SD-□CW	○	○	○	○	○	○	○	○	○	○	○	○	○	○	○	○	○	○	○	○
	Mechanically Latched Type	SL-□	○	○	○	○	○	○	○	○	○	○	○	○	○	○	○	○	○	○	○	○
		SLD-□	○	○	○	○	○	○	○	○	○	○	○	○	○	○	○	○	○	○	○	○
	Class 2 Heat Resistance	S-□FN	○	○	○	○	○	○	○	○	○	○	○	○	○	○	○	○	○	○	○	○
	With Reversing Connecting Conductor (Both Power and Load Sides)	S-□SD	○	○	○	○	○	○	○	○	○	○	○	○	○	○	○	○	○	○	○	○
		SD-□SD	○	○	○	○	○	○	○	○	○	○	○	○	○	○	○	○	○	○	○	○
	With Power Side 3-Pole In-Phase Crossover Conductor	S-□SG	○	○	○	○	○	○	○	○	○	○	○	○	○	○	○	○	○	○	○	○
		SD-□SG	○	○	○	○	○	○	○	○	○	○	○	○	○	○	○	○	○	○	○	○
	With Load Side 3-Pole In-Phase Crossover Conductor	S-□SX	○	○	○	○	○	○	○	○	○	○	○	○	○	○	○	○	○	○	○	○
		SD-□SX	○	○	○	○	○	○	○	○	○	○	○	○	○	○	○	○	○	○	○	○
	With Load Side 3-Pole Reverse-Phase Switching Crossover Conductor	S-□SF	○	○	○	○	○	○	○	○	○	○	○	○	○	○	○	○	○	○	○	○
		SD-□SF	○	○	○	○	○	○	○	○	○	○	○	○	○	○	○	○	○	○	○	○

- Note 1. ◎ : Permanently in stock, depending on operation coil voltage and heater designation. ○ : Made to order.
- : Outside production range
- Note 2. The value between parentheses for the class AC-3 rated capacity applies to an enclosed magnetic starter.
- Note 3. T65 to N800 types have an AC control coil integrated surge absorber, rendering a coil surge absorber unit for prevention of coil switching surges unnecessary.
- Note 4. The +2b on the auxiliary contact arrangement of reversible T10 to T20 types indicates the break contact of the integrated UT-ML20 interlock unit. There is no need to specify when ordering.
- Note 5. Auxiliary contact arrangements for reversible types are displayed by twos, in a contact arrangement combining two magnetic contactors. For standard contact arrangements there is no need to specify when ordering; however, please specify a matching contact arrangement for 2 units if for a special configuration.
<Example> For 1b x 2 + 2b: 2B
- Note 6. Mechanically latched types and delay open types have differing auxiliary contact arrangements. Refer to page 102 for details about mechanically latched types, or page 111 for delay open types.
- Note 7. MSO(D)-(2x)T80CW(KP) heater designation 67A is not manufactured.
- Note 8. S-T12/T20 auxiliary contact 2b can be manufactured.

4.3 MSOD/SD-□ DC Operated Magnetic Starters/Magnetic Contactors

The operation coil is dedicated for DC

- The operation coil can be used with a separate power supply for DC operation.
(Main circuit can use both AC and DC)
- Electromagnet buzzing does not occur.
- The coil doesn't use saving resistance so there is no inrush current.
(Excluding N600, N800)
- SD-T12 to T32 and SD-N600, N800 type operation coil terminals have polarity.
Connect terminal number A1 (+) to the positive and A2 (-) to the negative sides.



SD-N220

● Ratings/Specifications (Standard Applicability)

Magnetic Contactors	Magnetic Starters (Note 10)	Rated Capacity [kW]				Rated Operating Current [A]						Conventional Free Air Thermal Current Ith [A]	Auxiliary Contact		Compatible Thermal Overload Relays	
		Three-Phase Squirrel-cage Motor (Category AC-3)				Three-Phase Squirrel-cage Motor (Category AC-3)				Resistive Load (Category AC-1)			Standard (Special)	Additional Unit Model Names x Pieces	Model Name	Heater Designation Range [A]
		AC220 to 240 V	AC380 to 440 V	AC500 V	AC690 V	AC220 to 240 V	AC380 to 440 V	AC500 V	AC690 V	AC100 to 240 V	AC380 to 440 V					
SD-T12(BC)	MSOD-T12(BC)KP	3.5[2.7]	5.5[4]	5.5[5.5]	5.5	13[13]	12[9]	9[9]	7	20	13	20	1a1b(2a)	UT-AX2, 4(BC) x 1 or UT-AX11(BC) x 2	TH-T18(BC)KP	0.12 to 11
SD-T20(BC)	MSOD-T20(BC)KP	4.5[3.7]	7.5[7.5]	7.5[7.5]	7.5	18[18]	18[18]	17[17]	9	20	18	20	2a2b		TH-T25(BC)KP	0.12 to 15
SD-T21(BC)	MSOD-T21(BC)KP	5.5[4]	11[7.5]	11[7.5]	7.5	25[20]	23[20]	17[17]	9	32	32	32	—		—	—
SD-T32(BC)	—	7.5[7.5]	15[15]	15[11]	11	32[32]	32[32]	24[20]	12	32	32	32	—	—	—	—
SD-T35(BC)	MSOD-T35(BC)KP	11[7.5]	18.5[15]	18.5[15]	15	40[35]	40[32]	32[26]	17	60	60	60	2a2b	UN-AX2, 4 x 1 or UN-AX11 x 2	TH-T25(BC)KP	0.24 to 22
SD-T50(BC)	MSOD-T50(BC)KP	15[11]	22[22]	25[22]	22	55[50][50] (Note 1)	50[48]	38[38]	26	80	80	80			TH-T50(BC)KP	29
SD-T65(CW)	MSOD-T65(CW)KP	18.5[15]	30[30]	37[30]	30	65[65]	65[65]	60[45]	38	100	100	100			TH-T25(BC)KP	0.24 to 22
SD-T80(CW)	MSOD-T80(CW)KP (Note 8)	22[19]	45[37]	45[45]	45	85[80]	85[80]	75[75]	52	120	120	120			TH-T50(BC)KP	29 to 42
SD-T100	MSOD-T100KP	30[22]	55[45]	55[45]	55	105[100]	105[93]	85[75]	65	150	150	150	UN-AX80 x 2	TH-T65KP	15 to 54	
SD-N125	MSOD-N125KP	37[30]	60[60]	60[60]	60	125[125]	120[120]	90[90]	70	150	150	150		TH-T100KP	67	
SD-N150	MSOD-N150KP	45[37]	75[75]	90[90]	90	150[150]	150[150]	140[140]	100	200	200	200	UN-AX150 x 2	TH-T65KP	15 to 54	
SD-N180	MSOD-N180KP	55[45]	90[90]	110[110]	110	180[180]	180[180]	180[180]	120	260	260	260		TH-T100KP	67, 82	
SD-N220	MSOD-N220KP	75[55]	132[110]	132[132]	132	250[220]	250[220]	200[200]	150	260	260	260	UN-AX600 x 1	TH-N120KP (TA)	42 to 105	
SD-N300	MSOD-N300KP	90[75]	160[150]	160[160]	200	300[300]	300[300]	250[250]	220	350	350	350		TH-N220KPRH	82 to 150	
SD-N400	MSOD-N400KP	125[110]	220[200]	225[200]	250	400[400]	400[400]	350[350]	300	450	450	450	TH-N400KPRH	105 to 250		
SD-N600	—	190[160]	330[300]	330[300]	330	630[630]	630[630]	500[500]	420	660	660	660	TH-N600KP (Note 4)	105 to 330		
SD-N800	—	220[200]	440[400]	500[400]	500	800[800]	800[800]	720[720]	630	800	800	800		250 to 500		
															250 to 600	

Note 1. The value in parentheses for the rated operating current is applicable in the case of magnetic contactors.

Note 2. Enclosed types are not manufactured.

Note 3. Also manufactured as reversible types (MSOD-2x□ types excluding SD-2x□, T32 and N600/N800).

Note 4. Use TH-N600 in combination with a separately sold current transformer (Mitsubishi CW-□).

Note 5. The magnetic starters listed below are also manufactured.

- Models with 2E Thermal Overload Relay: MSOD-T12KP to T100KP, MSOD-N125KP to N400KP
- Models with Quick Trip Thermal Overload Relay: MSOD-T12FSKP to T100FSKP, MSOD-T21FS to T100FS
- Models with Delayed Trip Thermal Overload Relay: MSOD-T12SR to T100SR, MSOD-T21KPSR to T100KPSR, MSOD-N125SR to N400SR, MSOD-N125KPSR to N400KPSR

Note 6. Refer to page 51 for information regarding application to resistive loads and capacitive loads.

Note 7. The main contact minimum operating Voltage and current differ depending on the allowable fault rate. Refer to page 42 for details.

Note 8. MSOD-T80CW heater designation 67A is not manufactured.

Note 9. MSOD-T□ and MSOD-N□ types can also be manufactured.

Note 10. SD-T12 and SD-T20 with spring clamp terminals (SQ) can also be manufactured.

● Handling

(1) T65 to T100 type and N125 to N800 type coils of DC100V or more cannot be switched by the auxiliary contacts of thermal overload relays (TH- □ types). Switch using the contactor relay (SR or SRD type) contacts as per the figure below.

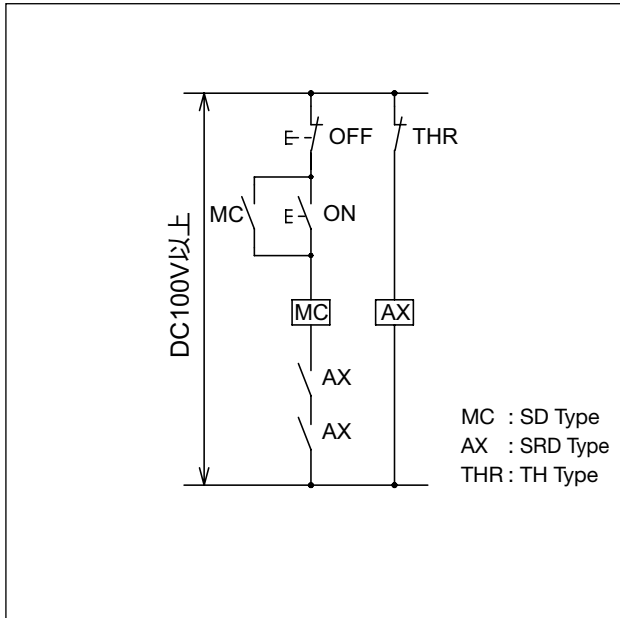

(2) Connecting differing DC operated magnetic contactor control circuits in parallel and simultaneously switching OFF can cause flip-flopping. As such, use one of the circuits listed below.

(MC1: Small Frame, MC2: Large Frame)

Circuit Example 1

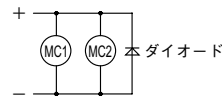

Effect of Changing Circuit

- It is necessary to restrict the polarity of the control circuit power supply.
- The open time of MC2 increases.

Circuit Example 2

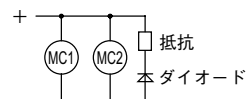

- It is necessary to restrict the polarity of the control circuit power supply.
- The open time of MC2 increases.

Circuit Example 3

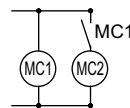

- The time until MC2 is activated increases.

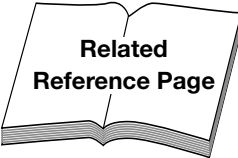
	Item	Reference Page	Remarks
	· Main Contact Rating	Page 39	—
· Auxiliary Contact Rating	Page 41	—	
· Operation Coil	Page 44	—	
· Properties	Page 45	—	
· Performance	Page 46	—	
· Outline Drawings/Contact Arrangements	Page 93	—	
· How to Order	Page 130	—	
· Combining with Optional Units	Page 194	—	

Note 1. The terminal numbers in parentheses for the S, SD, SL(D) auxiliary contacts in the center contact arrangement example are indicated along with the product, and represent the numbers of the old version (A Series).

N125

Non-Reversing

SD-N125

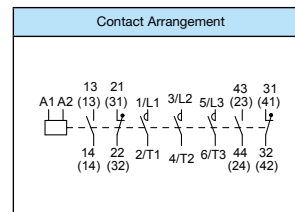
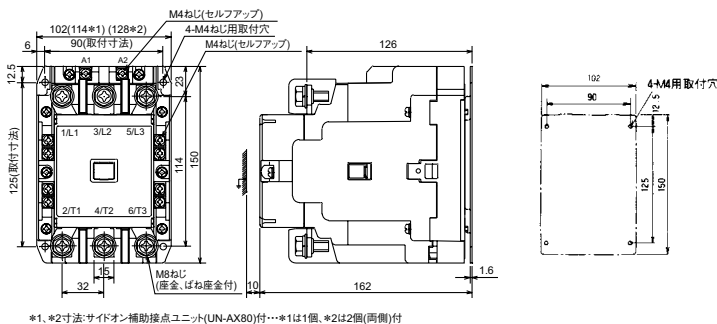
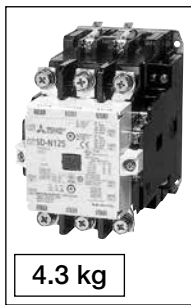

Model Name	SD-N125
------------	---------

Reversing

SD-2xN125

9.2 kg

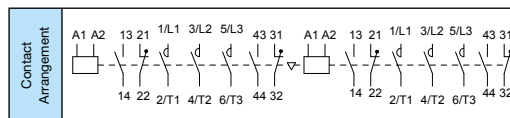
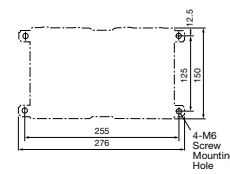
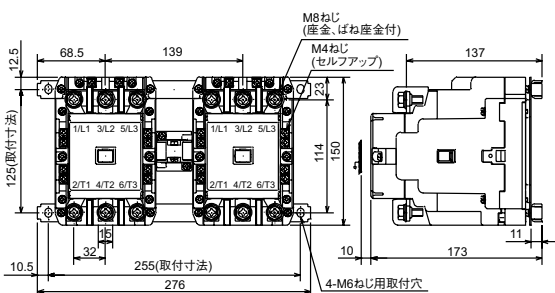

Model Name	SD-2xN125
------------	-----------

N150

Non-Reversing

SD-N150

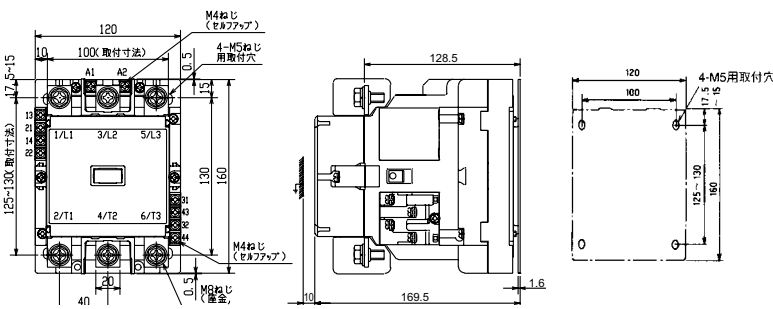

4

MS-T/N Series Magnetic Starters/Magnetic Contactors

Note 1. The terminal numbers in parentheses for the S, SD, SL(D) auxiliary contacts in the center contact arrangement example are indicated along with the product, and represent the numbers of the old version (A Series).

N220

Non-Reversing

SD-N220

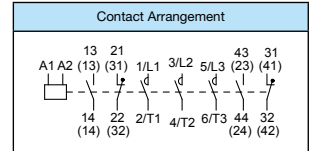
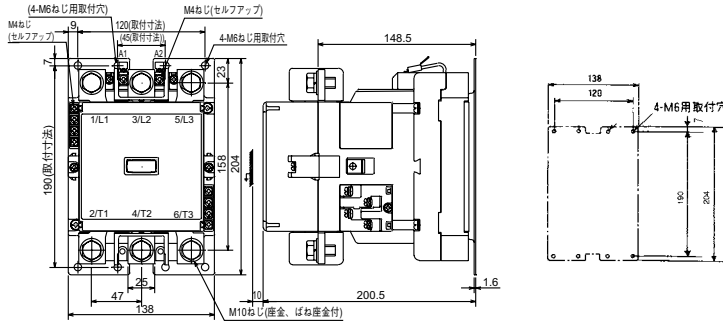

Model Name	Model Number
SD-N220	SN2981

Reversing

SD-2xN220

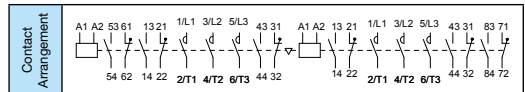
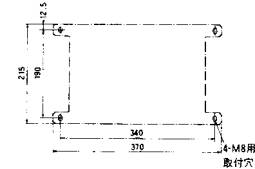
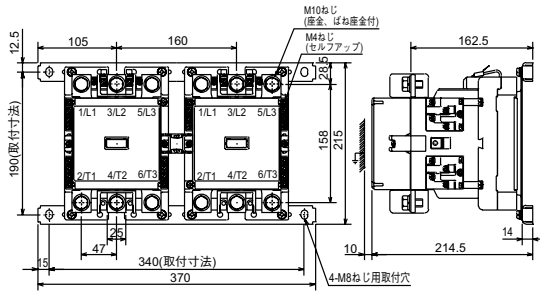

Model Name
SD-2xN220

17 kg

N300/N400

Non-Reversing

SD-N300

SD-N400

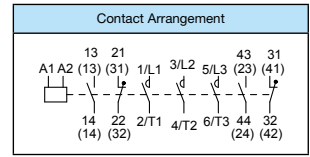
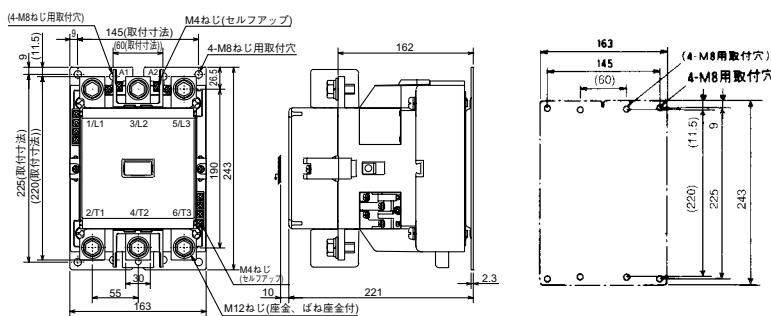

Model Name	Model Number
SD-N300	SN2991
SD-N400	SN3001

Reversing

SD-2xN300

SD-2xN400

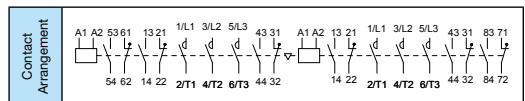
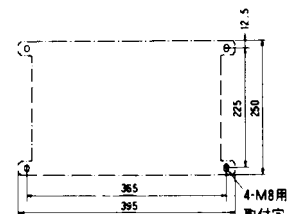
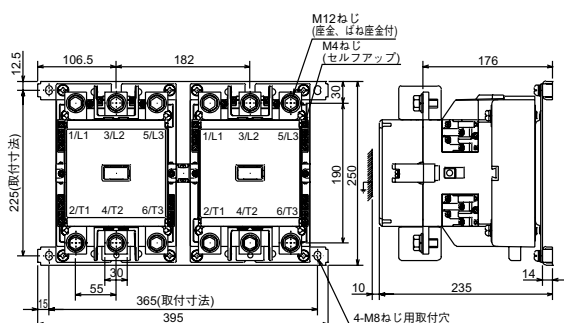

Model Name
SD-2xN300
SD-2xN400

28 kg
29 kg

Note 1. The terminal numbers in parentheses for the S, SD, SL(D) auxiliary contacts in the center contact arrangement example are indicated along with the product, and represent the numbers of the old version (A Series).

N600/N800

Non-Reversing

SD-N600
SD-N800



29 kg

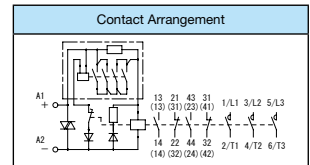
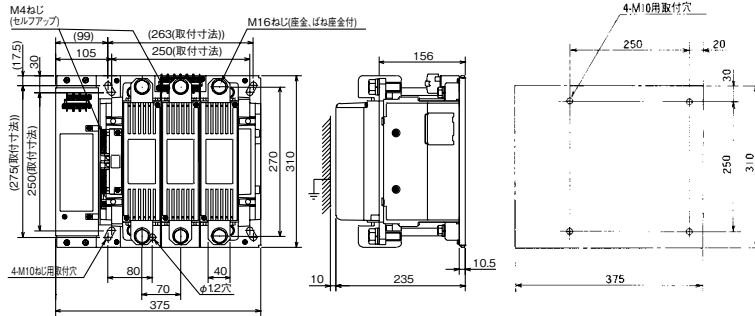

Model Name
SD-N600
SD-N800

Reversing

SD-2 x N600
SD-2 x N800



64 kg

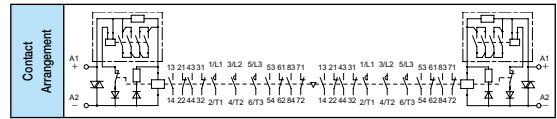
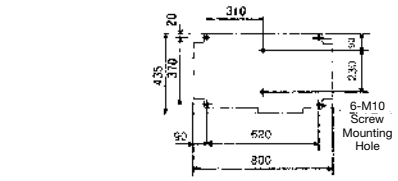
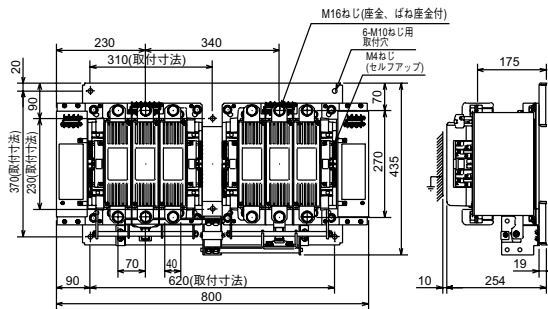

Model Name
SD-2xN600
SD-2xN800

4.4 MSOL(D)/SL(D)-□ Mechanically Latched Magnetic Starters/Magnetic Contactors

Contact doesn't open when power failures or voltage drops occur

- Installing a reliable mechanical latch mechanism to magnetic contactors and using the equipped closing and opening coils allows mechanical retention in the closed state. (Can also be operated manually)
- The magnetic contactor will not release due to power failures, momentary power failures or voltage drops.
- Power saving and no noise type as the coil is only momentarily energized and doesn't consume power in the regular state.
- Suitable for distribution panels, street lights, important facilities within buildings or the memory circuits of plants and more.
- Suitable for AC/DC power supply switching and power purchasing/self-generated power supply switching, with 2 units combined. (Applicable with MSOL(D)/SL(D)-2x □ types that have a mechanical interlock equipped as standard)

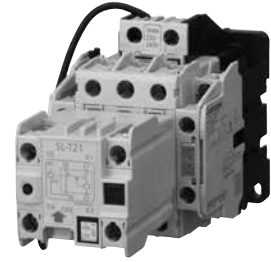

SL-T21

● Ratings/Specifications (Standard Applicability)

Magnetic Contactors	Magnetic Starters (Note 8)	Rated Capacity [kW]				Rated Operating Current [A]						Conventional Free Air Thermal Current I _{th} [A]	Auxiliary Contact (for Reversing)			Compatible Thermal Overload Relays	
		Three-Phase Squirrel-cage Motor (Category AC-3)				Three-Phase Squirrel-cage Motor (Category AC-3)				Resistive Load (Category AC-1)			Valid	For Self-Demagnetization (Built-in)	Additional Unit Model Names x Pieces	Model Name	Heater Designation Range [A]
		220 to 240 V	380 to 440 V	500 V	690 V	220 to 240 V	380 to 440 V	500 V	690 V	200 to 240 V	380 to 440 V						
SL-T21(BC)	MSOL-T21(BC)KP	5.5 [4]	11 [7.5]	11 [7.5]	7.5	25 [20]	23 [20]	17 [17]	9	32	32	32	2a2b (2a2b x 2)	UT-AX11(BC) x2	TH-T25(BC)KP	0.24 to 22	
SL-T35(BC)	MSOL-T35(BC)KP	11 [7.5]	18.5 [15]	18.5 [15]	15	40 [35]	40 [32]	32 [26]	17	60	60	60			TH-T50(BC)KP	29	
SL-T50(BC)	MSOL-T50(BC)KP	15 [11]	22 [22]	25 [22]	22	55 [50]	50 [48]	38 [38]	26	80	80	80			TH-T25(BC)KP	0.24 to 22	
SL-T65	MSOL-T65KP	18.5 [15]	30 [30]	37 [30]	30	65 [65]	65 [65]	60 [45]	38	100	100	100			TH-T50(BC)KP	29 to 42	
SL-T80	MSOL-T80KP	22 [19]	45 [37]	45 [45]	45	85 [80]	85 [80]	75 [75]	52	120	120	120		UN-AX11x2	TH-T65KP	15 to 54	
SL-T100	MSOL-T100KP	30 [22]	55 [45]	55 [45]	55	105 [100]	105 [93]	85 [75]	65	150	150	150		1a2b (1a2b x 2)	TH-T100KP	67	
SL-N125	MSOL-N125KP	37 [30]	60 [60]	60 [60]	60	125 [125]	120 [120]	90 [90]	70	150	150	150		1a2b (1a2b x 2)	UN-AX11x2	TH-T65KP	15 to 54
SL-N150	MSOL-N150KP	45 [37]	75 [75]	90 [90]	90	150 [150]	150 [150]	140 [140]	100	200	200	200		1a2b (1a2b x 2)	UN-AX80x2 (UN-AX80x2)	TH-T100KP	67, 82
SL-N220	MSOL-N220KP	75 [55]	132 [110]	132 [132]	132	250 [220]	250 [220]	200 [200]	150	260	260	260		1a2b (2a3b x 2)	UN-AX150x2 (-)	TH-N120KP(TA)	42 to 105
SL-N300	MSOL-N300KP	90 [75]	160 [150]	160 [160]	200	300 [300]	300 [300]	250 [250]	220	350	350	350		1a2b (3a4b x 2)	UN-AX150x2 (-)	TH-N150KP	42 to 125
SL-N400	MSOL-N400KP	125 [110]	220 [200]	225 [200]	250	400 [400]	400 [400]	350 [350]	300	450	450	450	1a2b	UN-AX150x2 (-)	TH-N220KPRH	82 to 180	
SL-N600	—	190 [160]	330 [300]	330 [300]	330	630 [630]	630 [630]	500 [500]	420	660	660	660	1a2b	UN-AX600x1 (-)	TH-N400KPRH	105 to 250	
SL-N800	—	220 [200]	440 [400]	500 [400]	500	800 [800]	800 [800]	720 [720]	630	800	800	800	1a2b (3a4b x 2)	UN-AX600x1 (-)	TH-N600KP (Note 3)	105 to 330	
																250 to 500	
																250 to 660	

Note 1. The value in parentheses for the rated operating current is applicable in the case of magnetic contactors.

Note 2. Use model names SLD-T□, SLD-N□ or MSOLD-T□, MSOLD-N□ for DC closing coils.

Note 3. Use TH-N600 in combination with a separately sold current transformer (Mitsubishi CW-□).

Note 4. Reversing (SL(D)-2 x T□, SL(D)-2 x N□ or MSOL(D)-2 x T□, MSOL(D)-2 x N□ types) can also be manufactured.

Note 5. Refer to page 51 for information regarding application to resistive loads and capacitive loads.

Note 6. The main contact minimum operating voltage and current differ depending on the allowable fault rate. Please refer to page 42 for details.

Note 7. No specification needs to be made for contact arrangements that are valid and self-demagnetizing.

Note 8. MSOL(D)-T□ and MSOL(D)-N□ types can also be manufactured.

● Operating Transformer Capacity, Capacitive Tripping

Frame	Operating Transformer Capacity (For AC Operation) (VA)	Minimum Capacitance For Capacitive Tripping (For AC200 V) (μ F)	Capacitive Tripping Device Model Name	
			Note 2 AC100V	AC200V
T21	75 to 100	40	CTU-A1	CTU-A2
T35	75 to 100	40		
T50	75 to 100	40		
T65	75 to 100	150		
T80	75 to 100	150	CTU-B1	CTU-B2
T100	100 to 150	150		
N125	100 to 150	150		
N150	100 to 150	150		
N220	150 to 200	150		
N300	200 to 300	150	CTU-C1	CTU-C2
N400	200 to 300	150		
N600	300 to 400	600		
N800	300 to 400	600		

- Note 1. The minimum capacitance for capacitive tripping is the value required to trip the circuit within 5 seconds of a power failure.
- Note 2. CTU type capacitive tripping device specifications.
- Charging for at least 10 seconds at the rated voltage allows for tripping up to 30 seconds after a power failure.
 - Tripping Coil Rated Voltage/Frequency
For AC100 V: 100 to 110 V, 50/60 Hz
For AC200 V: 200 to 220 V, 50/60 Hz
 - Uses an electrolytic capacitor, so the capacity should be checked periodically.
- Note 3. An electrolytic capacitor is used. Touching the conductive portion may cause an electric shock even if the rated voltage is OFF. Check if the product has been completely discharged by using methods such as shorting terminals 1 and 2 through the resistor before starting maintenance.

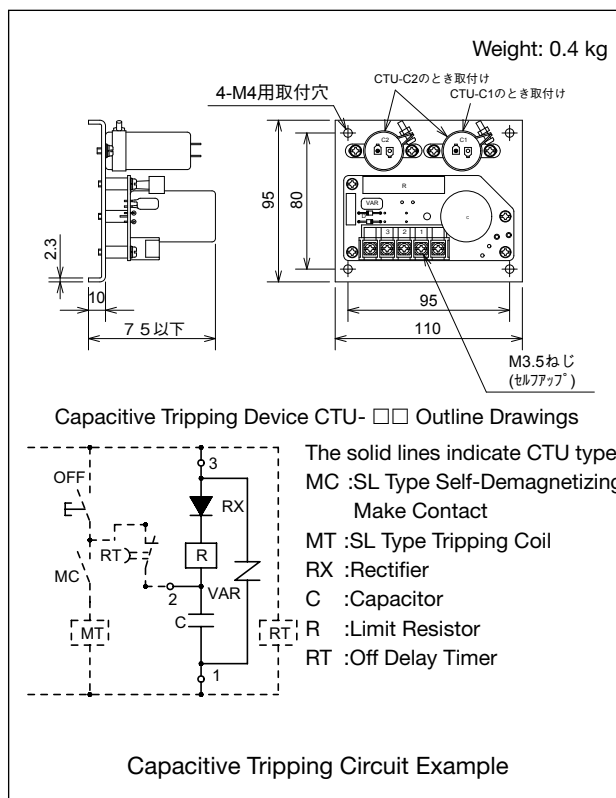

● Structure/Operation

● Structure

The latch is installed above the unit for T21 to T80 types and beneath the power supply side the unit for T100 and N125 to N800 types. The figure below shows a typical application.

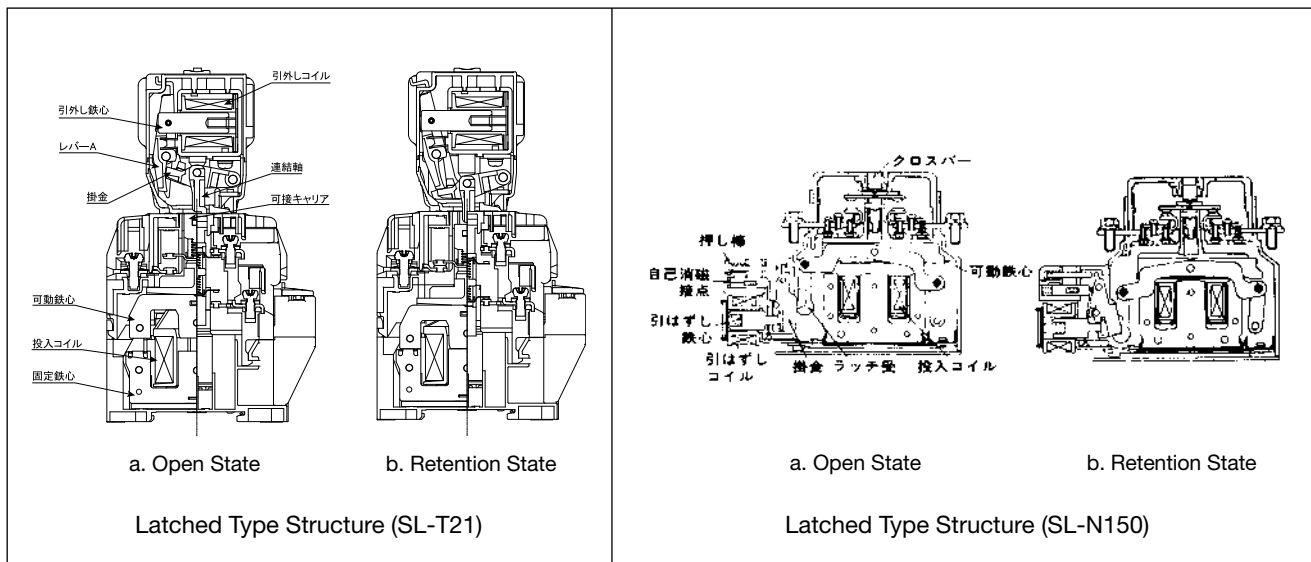

● Operation

Closing

- (1) Energizing the closing coil attracts the movable core, engaging lever A or the latch receiver to the latch while simultaneously close-circuiting the main contact.
- (2) When the latch engages the self-demagnetizing contact is open-circuited, stopping current to the closing coil and completing the close.

Tripping

- (1) Energizing the tripping coil attracts the movable core, freeing lever A or the latch receiver from the latch.
- (2) When the latch is released the movable core returns to its original position and the main contact is opened.

● Manual Operation

The contactors can be manually operated for the purpose of sequence checking. Manually close or trip the contactor using a screwdriver as per figures 2 to 5. However, do not operate manually if a current is flowing through the main circuit, as there is a risk of electric shock due to arcing.

● Control Command Duration (Minimum Energize Time)

The command duration of external switches that direct the closing coil or tripping coil must be 0.3 seconds or more for T21 to T100 and N125 to N220 types and 0.5 seconds or more for N300 to N800 types.

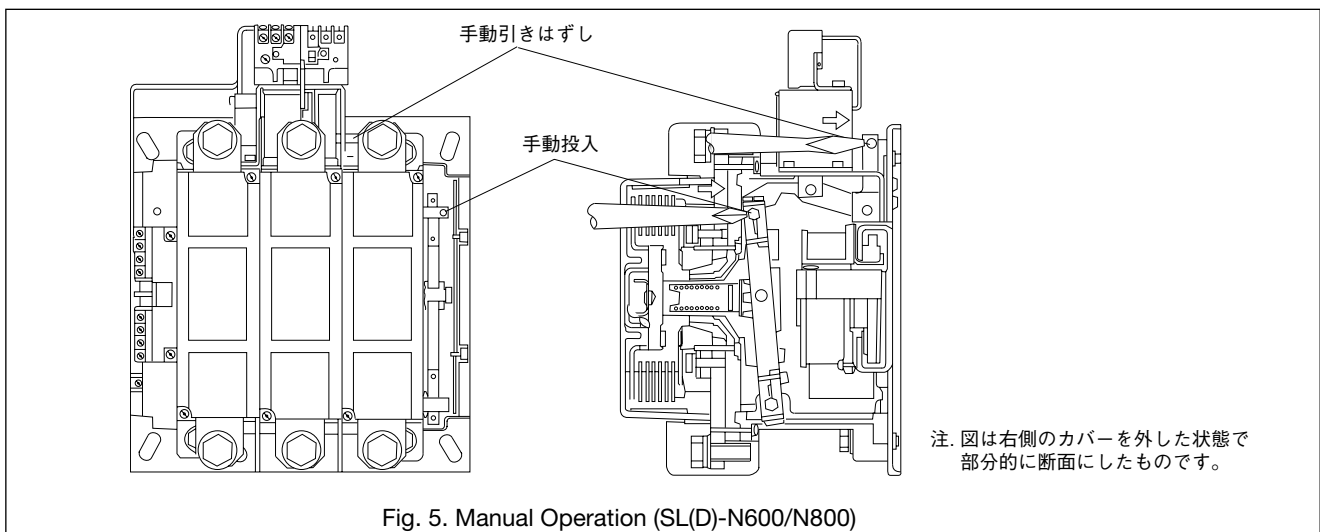
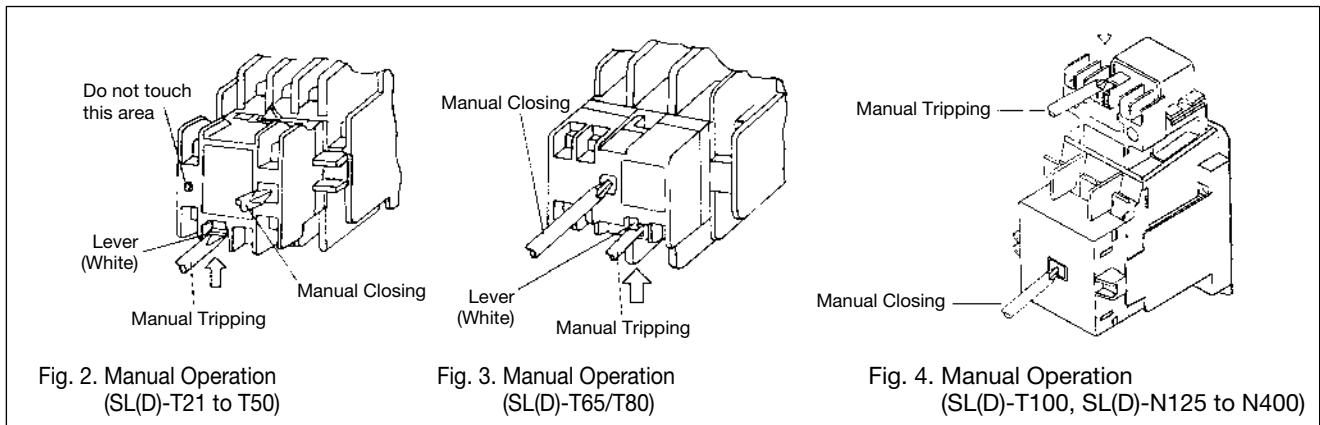
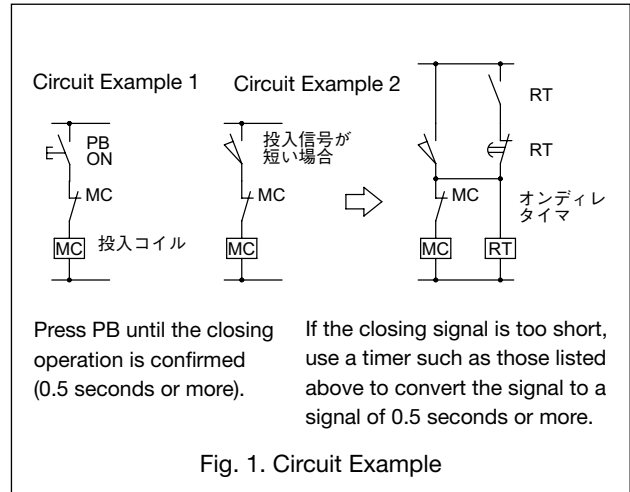

● Handling

● Model Name

An SL in the model name indicates an AC closing coil while SLD indicates a DC closing coil. Magnetic starter (with thermal overload relay) model names are either MSOL type or MSOLD type.

● Operation Coils

S and SD types have different coil rated operational voltage ranges for both closing and tripping coils. The closing and tripping coils are both short-rated for 15 second operation, so be sure to connect a self-demagnetizing contact in series with the coil. The allowable range of the applied voltage is 85 to 110% of the rated voltage.

● Operating Switch Contact Capacity

Caution is required as the coil input to SL and SLD types is greater than that for S and SD types. Coil breaking in regular operation is done by the self-demagnetizing contact, so operation is possible using a closing relay or operating switch with making capacity equivalent to the coil input. However, in some cases the command duration is too short (approx. 0.5 seconds required), or breaking may be triggered by external shocks, so a contact with breaking capacity should be used.

● Closing and Tripping Commands

Configure your system such that the closing switch and tripping switch command signals never overlap (simultaneous contact).

● Power Supply Capacity

Caution is required as the momentary input to the operation coil is greater than that for S and SD types.

● Control Circuit Wiring

Do not remove the wiring for the operation coil and self-demagnetizing contact (bold lines in figure below) but wire according to the caution nameplate attached to the unit.

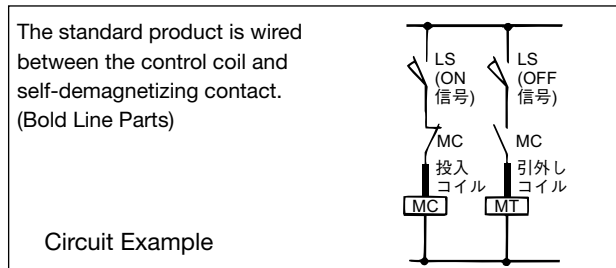

● Disassembly

Mechanically latched magnetic contactors are calibrated assembled products, so the coil cannot be replaced or disassembled. (Do not disassemble.)

● Application Example

Fig. 6. shows an example using a latched type for both regular and backup use with switched power supplies. Fig. 7. shows an example using a latched type for regular operation and a standard type (without latch) for backup use. When switching with a timer use periods of 0.2 seconds or more.

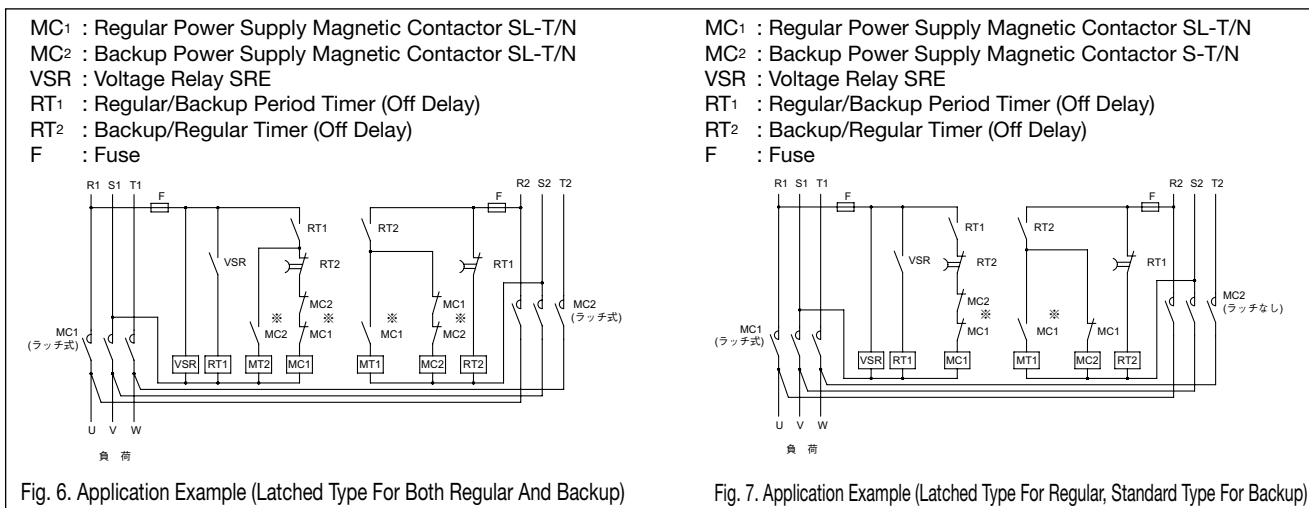

Note. * contacts are self-demagnetizing contacts wired to the closing coil (MC1, MC2) or tripping coil (MT1, MT2).

	Item	Reference Page	Remarks
<p>Related Reference Page</p>	· Main Contact Rating	Page 39	—
	· Auxiliary Contact Rating	Page 41	—
	· Operation Coil	Page 44	—
	· Properties	Page 46	—
	· Performance	Page 46	—
	· Outline Drawings/Contact Arrangements	Page 106	—
	· How to Order	Page 130	—
	· Combining with Optional Units	Page 194	—

4

MS-T/N Series Magnetic Starters/Magnetic Contactors

Note 1. The terminal numbers in parentheses for the S, SD, SL(D) auxiliary contacts in the center contact arrangement example are indicated along with the product, and represent the numbers of the old version (A Series).

N125

Non-Reversing

SL(D)-N125

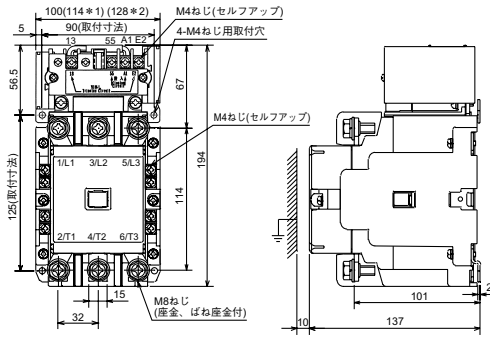

*1, *2寸法: サイドオン補助接点ユニット(UN-AX80)付... *1は1個, *2は2個(両側)付

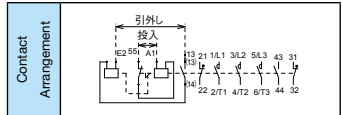
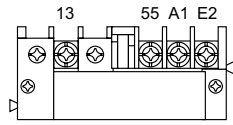
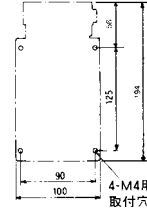

Model Name	Model Number	Model Name	Model Number
SL-N125	SLN05 □□	SLD-N125	SLN3541

Reversing

SL(D)-2xN125

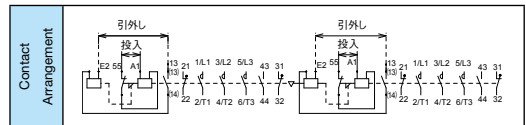
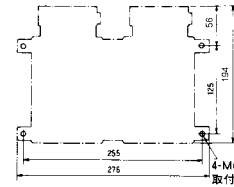
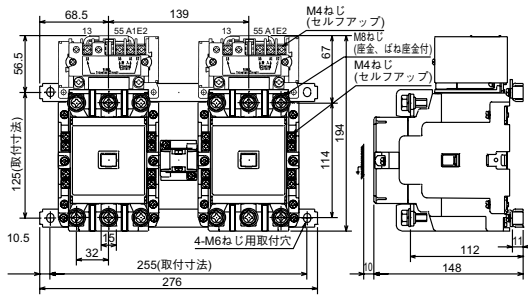

Model Name	Model Name
SL-2xN125	SLD-2xN125

7.0 kg

N150

Non-Reversing

SL(D)-N150

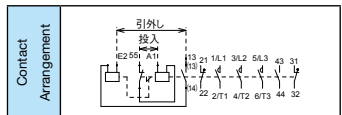
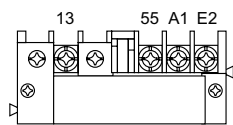
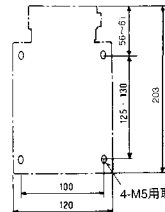
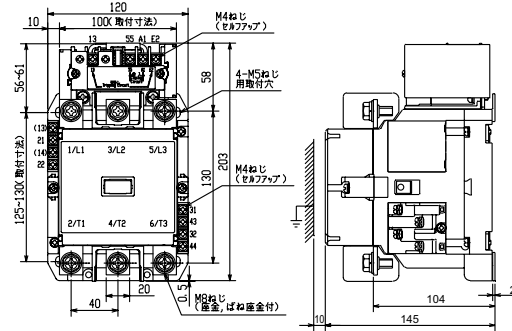

Model Name	Model Number
SL-N150	SLN06 □□
SLD-N150	SLN355

Reversing

SL(D)-2xN150

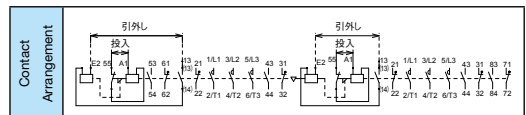
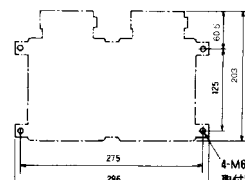
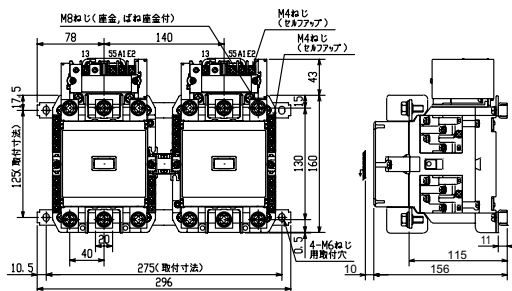

Model Name	Model Number
SL-2xN150	SLN1 □□□
SLD-2xN150	

8.0 kg

4

MS-T/N Series Magnetic Starters/Magnetic Contactors

Note 1. The terminal numbers in parentheses for the S, SD, SL(D) auxiliary contacts in the center contact arrangement example are indicated along with the product, and represent the numbers of the old version (A Series).

■ N600/N800

Non-Reversing

SL(D)-N600
SL(D)-N800

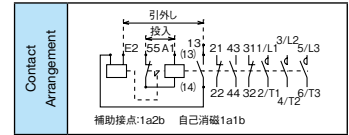
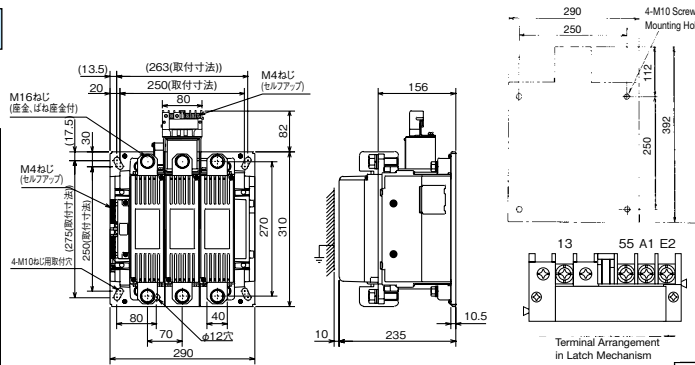

Model Name	Model Number	Model Name	Model Number
SL-N600	SNL0681	SLD-N600	
SL-N800		SLD-N800	

Reversing

SL(D)-2 × N600
SL(D)-2 × N800

60 kg

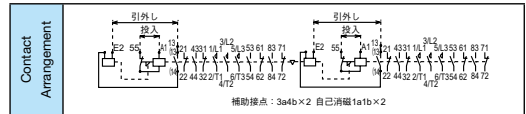
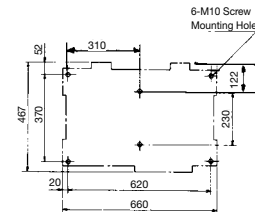
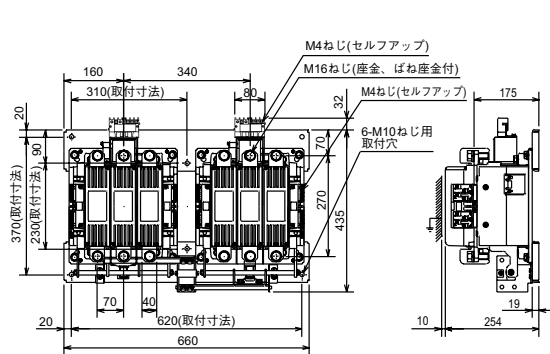

Model Name	Model Name
SL-2xN600	SLD-2xN600
SL-2xN800	SLD-2xN800

4.5 MSO/S-□DL Delay Open Magnetic Starters/Magnetic Contactors

Retains the closed state for 2^{+2}_{-1} seconds during a momentary power failure

- In cases of momentary power failures or momentary voltage drops due to lightning strikes on wiring etc., the discharge from a capacitor allows the closed state to be retained for 2^{+2}_{-1} seconds.
- No re-closing operations for magnetic contactors are required when power is restored, which makes continuous load operation possible.
- Suitable for temporary storage circuitry in illumination equipment or automatic control devices.

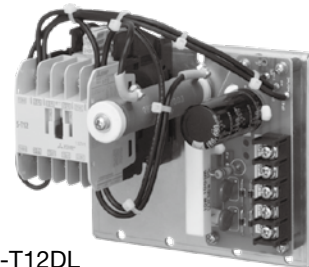

S-T12DL

● Ratings/Specifications (Standard Applicability)

Magnetic Contactors	Magnetic Starters (Note 8)	Rated Capacity [kW]				Rated Operating Current [A]				Conventional Free Air Thermal Current Ith [A]	Auxiliary Contact		Compatible Thermal Overload Relays			
		Three-Phase Squirrel-cage Motor (Category AC-3)				Three-Phase Squirrel-cage Motor (Category AC-3)					Resistive Load (Category AC-1)		Valid	Additional Unit Model Names x Pieces	Model Name	Heater Designation Range [A]
		220 to 240 V	380 to 440 V	500 V	690 V	220 to 240 V	380 to 440 V	500 V	690 V		200 to 240 V	380 to 440 V				
S-T12DL	MSO-T12DLKP	3.5 [2.7]	5.5 [4]	5.5 [5.5]	5.5	13 [13]	12 [9]	9 [9]	7	20	13	20	—	— Note 3	TH-T18KP	0.12 to 11
S-T21DL	MSO-T21DLKP	5.5 [4]	11 [7.5]	11 [7.5]	7.5	25 [20]	23 [20]	17 [17]	9	32	32	32	1a1b		TH-T25KP	0.24 to 22
S-T35DL	MSO-T35DLKP	11 [7.5]	18.5 [15]	18.5 [15]	15	40 [35]	40 [32]	32 [26]	17	60	60	60	1a1b		TH-T25KP	0.24 to 22
S-T50DL	MSO-T50DLKP	15 [11]	22 [22]	25 [22]	22	55 [50] [50] (Note 1)	50 [48]	38 [38]	26	80	80	80			TH-T50KP	29
S-T65DL	MSO-T65DLKP	18.5 [15]	30 [30]	37 [30]	30	65 [65]	65 [65]	60 [45]	38	100	100	100			TH-T25KP	0.24 to 22
S-T80DL	MSO-T80DLKP	22 [19]	45 [37]	45 [45]	45	85 [80]	85 [80]	75 [75]	52	120	120	120			TH-T50KP	29 to 42
S-T100DL	MSO-T100DLKP	30 [22]	55 [45]	55 [45]	55	105 [100]	105 [93]	85 [75]	65	150	150	150	1a1b		TH-T65KP	15 to 54
S-T100DL	MSO-T100DLKP	30 [22]	55 [45]	55 [45]	55	105 [100]	105 [93]	85 [75]	65	150	150	150			TH-T65KP (Note 8)	67
S-N150DL	MSO-N150DLKP	45 [37]	75 [75]	90 [90]	90	150 [150]	150 [150]	140 [140]	100	200	200	200	1a1b		TH-T100KP	15 to 54
S-N220DL	MSO-N220DLKP	75 [55]	132 [110]	132 [132]	132	250 [220]	250 [220]	200 [200]	150	260	260	260			TH-N120KP(TA)	42 to 125
S-N300DL	MSO-N300DLKP	90 [75]	160 [150]	160 [160]	200	300 [300]	300 [300]	250 [250]	220	350	350	350		TH-N220KPRH	82 to 180	
S-N400DL	MSO-N400DLKP	125 [110]	220 [200]	225 [200]	250	400 [400]	400 [400]	350 [350]	300	450	450	450		TH-N400KPRH	105 to 250	
S-N400DL	MSO-N400DLKP	125 [110]	220 [200]	225 [200]	250	400 [400]	400 [400]	350 [350]	300	450	450	450	—	—	105 to 330	

Note 1. The value in parentheses for the rated operating current is applicable in the case of magnetic contactors.

Note 2. The combining magnetic contactor is dedicated for use with T50 or less AC operated type (S type), or T65 to 100 and N125 or greater DC operated type (SD type), and cannot be replaced alone.

Note 3. Auxiliary contact units UN-AX150 can be installed on the left side for N150DL to N400DL types; however, T12DL to T100DL types cannot be used to mount additional auxiliary contact units.

Note 4. Magnetic starters can be manufactured to have 3-element (2E) thermal overload relays (MSO- □ DLKP) included.

Note 5. MSO-T12 to T100DL(KP)SR (with saturable reactors and thermal overload relays) cannot be manufactured.

Note 6. Instantaneous stop/restart relays (JA-DL2) are also available as related products. Refer to page 346.

Note 7. Cannot be used with live part protection covers. Furthermore, types with wiring streamlining terminals (BC) cannot be manufactured.

Note 8. Thermal overload relay dedicated for MSO-T80DL 67 A. S-T80DL and the standard TH-T100 67A cannot be combined for use as a magnetic starter.

Note 9. MSO-T□DL and MSO-N□DL types can also be manufactured.

● Properties/Performance/Operation Coil

Frame	Input [VA]		Operating Voltage [V]		Operating Time [ms]		Operation Coils		Making and Breaking Current Capacities	Switching Frequency	Switching Durability [x 10000]		Delay Time				
	Inrush	Normal	Close	Open	Operating Power ON →Main Contact ON	Operating Power OFF →Main Contact OFF	Designation	Rated Voltage			Mechanical	Electrical (Category AC-3)					
T12DL	70	13	85% or Less of Operation Coil Rated Voltage	10% or More of Operation Coil Rated Voltage	7 to 100		AC100V	100 to 110V 50/60 Hz	10 Times Class AC-3 Rated Operating Current	1200 Times/Hour	100	100	2^{+2}_{-1} Seconds (Fixed)				
T21DL	100	15			7 to 100						10 to 100						
T35DL	113	24			7 to 100												
T50DL	113	24			7 to 100												
T65DL	55	26			30 to 100						AC200V			200 to 220V 50/60 Hz	8 Times Class AC-3 Rated Operating Current	500	50
T80DL	55	26			30 to 100												
T100DL	66	27			30 to 100												
N150DL	76	55			30 to 100												
N220DL	100	66			30 to 100												
N300DL	140	85	30 to 100														
N400DL	140	85	30 to 100														

Note 1. The above indicates rough property indices for AC200V coils.

Note 2. The input is the average when applying 220 V at 60 Hz. Values for AC100V coils are approximately the same.

Note 3. The operating time is the value when applying 200 V at 60 Hz. Values for AC100V coils are approximately the same.

Note 4. Operation coils are only AC100V or AC200V.

Connecting

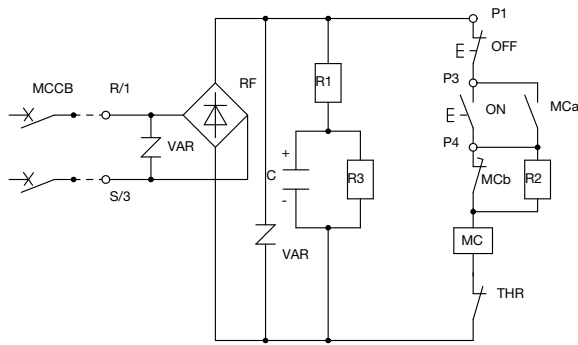

Deployment Connection Diagram

Note 1. The figure to the left is for MSO-□DL.

Note 2. The MCCB, ON and OFF buttons in the figure to the left are not provided.

Note 3. If connecting an external magnetic coil or indicator lamp, connect between the R/1 and S/3 terminals.

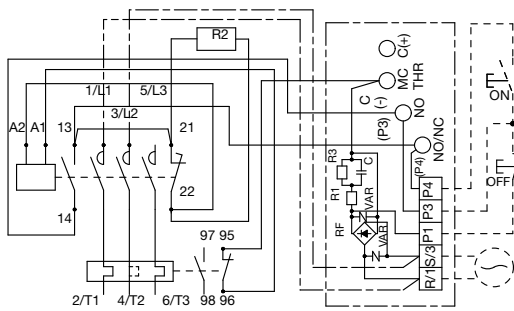

MSO-T12DL(KP) Actual Wiring Diagram

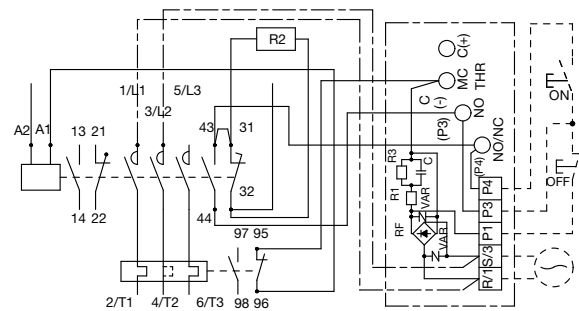

MSO-T21DL(KP) Actual Wiring Diagram

The connections shown with single-dashed lines between the L1-R/1 and L2-S/3 terminals are not wired if the control circuit voltage is AC100 V or if the main circuit and control circuit voltages differ.

Operation Description (Deployment Connection Diagram)

Power Supply Closing

Closing the power supply with **MCCB** causes **C** to charge via **RF** and **R1**.

Closing Magnetic Contactors

Pressing the **ON** button causes **MC** to energize via **MCb**, closing the contactor.

When **MC** has completed closing, **MCb** opens and, in the order of **MCa** → **R2** → **MC**, the current flows to retain the contactor.

Opening Magnetic Contactors

Pressing the **OFF** button cuts off current to **MC**, instantly opening the magnetic contactor.

When Power Supply Voltage Drops and Momentary Power Failures Occur

Charge accumulated in **C** discharges via **R1** → **R2** → **MC** circuits, opening **MC** after a predetermined time (after the delay time).

Handling (Deployment Connection Diagram)

- If ON and OFF for **MCCB** are repeated at short intervals (or when momentary power failures occur several times in quick succession) the following may occur
 - (1) The inrush current to **RF** and **R1** repeatedly flows, causing overloading.
 - (2) Sufficient charge is not provided to **C**, causing damage to components or insufficient retention time.
- Even when the power is OFF (**MCCB** is OFF), charge may still reside within **C**, so necessary precautions should be taken to avoid electric shocks.
- ON and OFF operations should be conducted using the push-button switch located as in the figure above. The magnetic contactor may flip-flop when the power is switched ON or OFF. Also, when switching the power to perform sequence checks etc., the operator should allow at least 5 seconds for the capacitor to charge.
- Uses an electrolytic capacitor so the delay time should be checked periodically.

● Outline Drawings

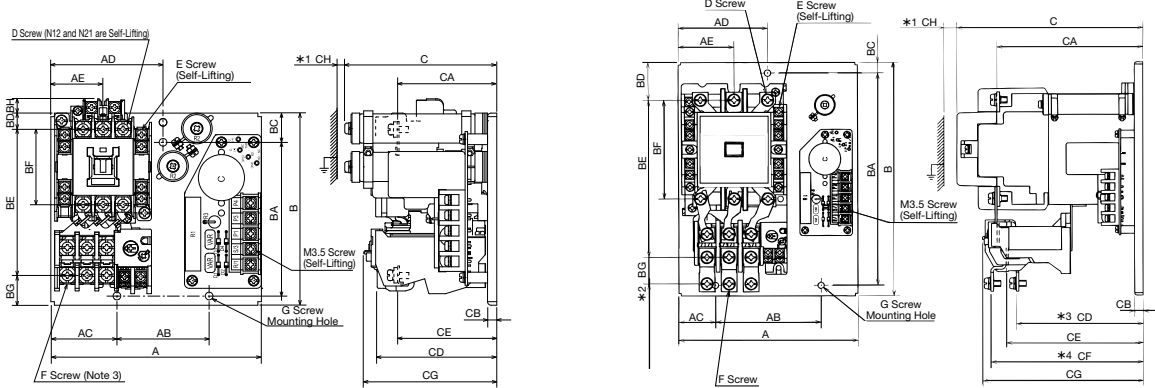

MSO/S-T12, T21, T35, T50DL
MSO/S-T65 to T100DL
MSO/S-N125 to N400DL

◆Caution Do not install wiring or other equipment in the vicinity of the resistor (refer to the figure above) as it reaches high temperatures (approx. 100°C temperature rise).

Variable Dimensions Table

Variable Dimensions	A	AB	AC	AD	AE	B	BA	BC	BD	BE	BF	BG	BH	C	CA	CB	CD	CE	CF	CG	CH	D	E	F	G
Frame																									
T12DL	132	40	49	69	29.8	110	100	5	11.2	83	41.6	—	12.5	113	65	6	—	43	—	85	5	M3.5	M3.5	—	3-M4
T21DL	137	60	43	73	34	125	100	19	10.5	94.5	49	—	11	113	65	6	—	65	—	88	5	M4	M3.5	—	3-M4
T35/T50DL	134	50	42	67	38.5	162	150	6	23	103	55	21.5	—	114	70.5	8	69.5	67	—	89	5	M5	M3.5	M5	3-M4
T65/T80DL	150	50	56	81	50	168	150	9	27	126	74	—	—	141	103.5	8	—	95.5	—	118	5	M6	M4	M6	3-M5
T100DL	170	100	35	85	53	220	200	10	35.5	148	93	20	—	165	127	8	109	118.5	133	141	10	M6	M4	M6	3-M6
N150DL	210	140	26	105	80	270	250	10	33	200	130	25	—	177.5	136.5	8	—	99.5	102	133.5	10	M8	M4	M8	3-M8
N220DL	230	140	20	90	90	290	250	12	31	246.5	158	—	—	208.5	156.5	8	—	103.5	—	214	10	M10	M4	—	3-M8
N300/N400DL	300	200	10	—	110	363.5	200	25	30	318.5	190	—	—	229	170	8	—	122.5	—	227	10	M12	M4	—	4-M8

Weight Table

	S-	MSO-
T12DL	0.73	0.84
T21DL	0.98	1.2
T35/T50DL	1.20	1.44
T65/T80DL	2.8	3.1
T100DL	3.9	4.4
N150DL	6.3	7.6
N220DL	9.1	11.6
N300/N400DL	15/15.5	17.5/18

- Note 1. *1: "CH" is the arc space.
 Note 2. Below indicates the case when using TH-T50/T100 and TH-N□TA thermal overload relays.
 *2: "BG" has extended terminal pitch, "F Screw" has a terminal screw on the load side
 *3: "CD" has load side 4/T2 terminal height
 *4: "CF" has load side 2/T1, 6/T3 terminal height
 Note 3. The F screw for MSO-T35/T50DL is M4 with heater designations of 22A or below.
 Note 4. The maximum outline drawings (A x B x C) of S-□DL and MSO-□DL are the same. However, S-N300/N400DL has a "B" dimension of 250.
 Note 5. The power connector protrudes from the product on the power supply side by approximately 15 mm.

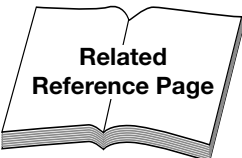
	Item	Reference Page	Remarks
	· Main Contact Rating	Page 39	—
	· Auxiliary Contact Rating	Page 41	—
	· How to Order	Page 133	Be sure to specify main circuit specifications and operation coil designation as both MSO-□DL and S-□DL may or may not require wiring from the main circuit.
	· Combining with Optional Units	Page 194	—

4.11 S(D)-T32, S-N□8 Main Circuit 3-Pole Magnetic Contactors

Dramatically reduces panel installation area required

- A space-saving type without auxiliary contacts equipped and just 3-pole main contacts.
- If auxiliary contacts are required, auxiliary contact units can be installed. (Reversing types have 2a2b x 2 installed)



S-T32

S-N48

● Ratings/Specifications (Standard Applicability)

Magnetic Contactors		Rated Capacity [kW]				Rated Operating Current [A]				Conventional Free Air Thermal Current [A]	Additional Auxiliary Contact Unit Model Name x Pieces (Note 2)	Terminal Screw Size (Standard Tightening Torque N·m)		Recommended Crimp Lug Size Compatible with Terminal			
		Three-Phase Squirrel-cage Motor (Category AC-3)				Three-Phase Squirrel-cage Motor (Category AC-3)						Resistive Load (Category AC-1)		Main Circuit	Control Circuit	Main Circuit	Control Circuit
Non-Reversing	Reversing	220 to 240 V	380 to 440 V	500 V	690 V	220 to 240 V	380 to 440 V	500 V	690 V	200 to 220 V	380 to 440 V	I _{th} [A]					
S-T32(BC) SD-T32(BC)	S-2 x T32(BC) SD-2 x T32(BC)	7.5	15	15	11	32	32	24	12	32	32	32	UT-AX2, 4 x 1 UT-AX11 x 2	M4 1.18 - 1.86 (1.47)	M3.5 0.94 - 1.51 (1.17)	1.25-4 to 5.5-4	1.25-3.5 to 2-3.5
S-N38(CX)	S-2 x N38(CX)	7.5	15	15		35	32	24		60	60	60	UN-AX2, 4 x 1 (Front Clip-on)	M5 2.06 - 3.33 (2.55)	M3.5 0.94 - 1.51 (1.17)	1.25-5 to 14-5	1.25-3.5 to 2-3.5
S-N48(CX)	S-2 x N48(CX)	11	15	15		50	35	24		80	80	80					

Note 1. The M4 main circuit terminal screw size for T32 types makes it unsuitable for applications exceeding 20 A in accordance with the Electrical Appliance and Material Safety Law.

Note 2. Reversing types already have 2 UT/UN-AX4 units installed so no more can be mounted. Furthermore, all side clip-on units (UT/UN-AX11) are not applicable.

Note 3. Types including thermal overload relays (MSO) are not manufactured.

Note 4. A "BC" in the model name indicates a wiring streamlining terminal, "CX" indicates a CAN terminal.

Note 5. Please note that SD-T32 type operation coil terminals have polarity. A1 (+), A2 (-)

● Properties/Performance

Model Name	Input [VA]		Power Consumption [W]	Coil Current [mA]	Operating Voltage [V]		Operating Time [ms]		Making Current Capacity [A] (Peak 0.5 ms)	Switching Frequency	Switching Durability [x 10000]	
	Momentary	Regular			Close	Open	Coil ON→ Main Contact ON	Coil OFF→ Main Contact OFF			Mechanical	Electrical (Category AC-3)
SD-T32	—	—	3.3 (2.2)	0.033	60 to 75	10 to 30	70 (95)	20	400	1800 Times/Hour	1000	200
S-T32	55	4.5	1.8	20	125 to 155	80 to 115	15 to 22	5 to 15	400			
S-N38	110	13	4.3	80	120 to 145	90 to 115	10 to 20	5 to 14	500	1200 Times/Hour	500	100
S-N48	110	13	4.3	80	120 to 145	90 to 115	10 to 20	5 to 14	670			

Note 1. The above table indicates rough property indices for DC100V coils for DC operated types and AC200V coils for AC operated types. The values in the parentheses for SD-T32 indicate rough property indices for DC12V or DC24V coils.

Note 2. The operating voltage is that at a 20°C cold state. (AC operated type values are for 60 Hz)

Note 3. The coil current is the average regular value with DC100V (DC operated type) or AC220 V at 60 Hz (AC operated type) applied.

Note 4. The operating time is the value with DC100V (DC operated type) or AC220 V at 60 Hz (AC operated type) applied.

Note 5. The coil input and power consumption are the average values.

Note 6. The electrical durability at the making current capacity lasts 100,000 operations.

	Item	Reference Page	Remarks
	· Main Contact Rating	Page 39	—
	· Operation Coil	Page 43	—
	· How to Order	Pages 131,133	—
	· Combining with Optional Units	Page 194	—

● MS-N Series

1. Standard (AC Operated) Magnetic Starters

■ MS-(2x)N Type (Enclosed Type)

Model Name	Motor Capacity	Main Circuit Voltage	Operation Coil Designation or Control Circuit Voltage/Frequency	(Note) Auxiliary Contact
MS-N125KP	30kW	200V	AC200V	
Refer to pages 74 and 75.	Select from page 48 or 139.	Do not apply AC voltage to the main circuit. (To distinguish it from the control circuit voltage)	Select the coil designation from page 43 or specify the control circuit voltage and frequency used.	Specify if using a special contact arrangement. Refer to page 41.

■ MSO-(2x)N Type (Open Type)

Model Name	Motor Capacity or Heater Designation (Knob Setpoint)	Main Circuit Voltage	Operation Coil Designation or Control Circuit Voltage/Frequency	(Note) Auxiliary Contact
MSO-N125KP	105A	200V	AC200V	
Refer to pages 74 and 75.	Select from page 48 or 139.	Do not apply AC voltage to the main circuit. (To distinguish it from the control circuit voltage)	Select the coil designation from page 43 or specify the control circuit voltage and frequency used.	Specify if using a special contact arrangement. Refer to page 41.

2. Standard (AC Operated) Magnetic Contactors

■ S-N Type, S-2xN Type

Model Name	Operation Coil Designation or Control Circuit Voltage and Frequency	(Note) Auxiliary Contact
S-N125	AC200V	
S-N125	AC110V 50Hz	
Refer to pages 74 and 75.	Select the coil designation from page 43 or specify the control circuit voltage and frequency used.	Specify if using a special contact arrangement. Refer to page 41.

3. DC Operated Magnetic Starters/Contactors

■ MSOD-N Type

Model Name	Motor Capacity or Heater Designation (Knob Setpoint)	Main Circuit Voltage	Operation Coil Designation	(Note) Auxiliary Contact
MSOD-N125KP	30kW	200V	DC100V	
Refer to page 91.	Select from page 48 or 139.	Do not apply AC voltage to the main circuit.	Select the coil designation from page 44.	Specify if using a special contact arrangement. Refer to page 41.

■ SD-N Type

Model Name	Operation Coil Designation	(Note) Auxiliary Contact
SD-N125	DC110V	
Refer to page 91. SD-2 x N50 is a reversing type.	Select the coil designation from page 44.	Specify if using a special contact arrangement. Refer to page 41.

4. Mechanically Latched Magnetic Starters/Contactors

■ MSOL-N Type

Model Name	Motor Capacity or Heater Designation (Knob Setpoint)	Main Circuit Voltage	Closing Coil	Tripping Coil
MSOL-N125KP	30kW	200V	MC-AC200V	MT-AC200V
MSOLD-N125KP	105A	200V	MC-DC100V	MT-DC200V
Specify "MSOLD" if using a DC operated closing coil. Refer to page 102.	Select from page 48 or 139.	Do not apply AC voltage to the main circuit. (To distinguish it from the control circuit voltage)	Select the coil designation from page 44.	

■ SL-N Type, SLD-N Type

Model Name	Closing Coil Designation	Tripping Coil Designation
SL-N125	MC-AC100V	MT-AC100V
SLD-N125	MC-DC100V	MT-DC100V
Refer to page 102. · The model name is SLD if using a DC operated closing coil.	Select the coil designation from page 44.	

■ SL-2xN Type, SLD-2xN Type

Specify using the SL-N or SL-D-N type listed above if the left and right closing coils or tripping coils have the same ratings. However, specify using the following if the left and right coils have different ratings.

Model Name	Closing Coil Designation (Left Side)	Tripping Coil Designation (Left Side)	Closing Coil Designation (Right Side)	Tripping Coil Designation (Right Side)
SLD-2xN125	MC1-DC100V	MT1-AC100V	MC2-AC100V	MT2-DC100V
Refer to page 102. · The model name is SLD if using a DC operated closing coil.	Select the coil designation from page 44.			

5. Capacitive Tripping Device

■ CTU-□□Type

Model Name	Operating Voltage Symbol
CTU-A	2
Refer to page 103. Combinable Mechanically Latched Magnetic Starters · Model names differ depending on contactor frame.	Operating Voltage is AC100V or AC200V 1: AC100V 2: AC200V

6. Delay Open Magnetic Starters/Contactors

MSO-N DLKP, S-N DL Type

Model Name	Main Circuit Specifications	Operation Coils
MSO-N150DLKP S-N400DL	▲ 125A ▲ 200V ▲ 200V	▲ AC200V ▲ AC200V
Specify from page 111.	Specify the rated voltages of the thermal overload relay heater designation and main circuit. Be sure to specify the rated voltage as there are strict criteria for the internal wiring of magnetic contactors.	The operation coil designation is available in AC100V and AC200V.

7. Magnetic Starters with Delay Trip Thermal Overload Relays

MSO-N KPSR Type

Model Name	Motor Capacity or Heater Designation (Knob Setpoint)	Main Circuit Voltage	Operation Coil Designation or Control Circuit Voltage/Frequency	(Note) Auxiliary Contact
MSO-N125KPSR	▲ 30kW	▲ 200V	▲ AC200V	
Specify from page 114.	Select from page 48 or 139.	Do not apply AC voltage to the main circuit.	Select the coil designation from page 43 or specify the control circuit voltage and frequency used.	Specify if using a special contact arrangement. Refer to page 41.

8. Main Circuit 3-Pole Magnetic Contactors

S-N Type, S-2xN Type

Model Name	Operation Coil Designation or Control Circuit Voltage and Frequency
S-N48	▲ AC200V
Specify from page 127	Select the coil designation from page 43 or specify the control circuit voltage and frequency used.