

2.1 Model List

Frame			T10	T12	T20	T21	T25	T32	T35	T50		
Applicable standard			JIS C8201-4-1, IEC60947-4-1, EN60947-4-1, GB14048.4									
Model Name	Magnetic Contactors (Without Thermal Overload Relay, Open Type)	Non-Reversing	S-T10	S-T12	S-T20	S-T21	S-T25	S-T32	S-T35	S-T50		
		Reversing	S-2 x T10	S-2 x T12	S-2 x T20	S-2 x T21	S-2 x T25	S-2 x T32	S-2 x T35	S-2 x T50		
	Magnetic Starters (With standard 2-element, With Thermal Overload Relay)	Enclosed Type	Non-Reversing	MS-T10	MS-T12	—	MS-T21	—	—	MS-T35	MS-T50	
			Reversing	—	—	—	MS-2 x T21	—	—	MS-2 x T35	MS-2 x T50	
		Open Type	Non-Reversing	MSO-T10	MSO-T12	MSO-T20	MSO-T21	MSO-T25	—	MSO-T35	MSO-T50	
			Reversing	MSO-2 x T10	MSO-2 x T12	MSO-2 x T20	MSO-2 x T21	MSO-2 x T25	—	MSO-2 x T35	MSO-2 x T50	
	Combined Thermal Overload Relays			TH-T18			TH-T25			TH-T25 / T50	TH-T25 / T50	
	Magnetic Starters With 3-element type Thermal Overload Relays	Enclosed Type	Non-Reversing	MS-T10KP	MS-T12KP	—	MS-T21KP	—	—	MS-T35KP	MS-T50KP	
			Reversing	—	—	—	MS-2 x T21KP	—	—	MS-2 x T35KP	MS-2 x T50KP	
		Open Type	Non-Reversing	MSO-T10KP	MSO-T12KP	MSO-T20KP	MSO-T21KP	MSO-T25KP	—	MSO-T35KP	MSO-T50KP	
Reversing			MSO-2 x T10KP	MSO-2 x T12KP	MSO-2 x T20KP	MSO-2 x T21KP	MSO-2 x T25KP	—	MSO-2 x T35KP	MSO-2 x T50KP		
Combined Thermal Overload Relays			TH-T18KP			TH-T25KP			TH-T25 / T50KP	TH-T25 / T50KP		
Rated Insulation Voltage [V]			690									
Rated Impulse Withstand Voltage [kV]			6									
Rated Frequency [Hz]			50/60									
Pollution Degree			3									
Main contact rating	Rated operational current / power Category AC-3 (Note 1) (Three-phase squirrel-cage motor load standard responsibility) (Note 2) [kW/A]	AC220 to 240V	2.5/11 [2.2/11]	3.5/13 [2.7/13]	4.5/18 [3.7/18]	5.5/25 [4/20]	7.5/30 [5.5/28]	7.5/32 [7.5/32]	11/40 [7.5/35]	15/55 [11/50]		
		AC380 to 440V	4/9 [2.7/7]	5.5/12 [4/9]	7.5/18 [7.5/18]	11/23 [7.5/20]	15/30 [11/25]	15/32 [15/32]	18.5/40 [15/32]	22/50 [22/48]		
		AC500V	4/7 [2.7/6]	5.5/9 [5.5/9]	7.5/17 [7.5/17]	11/17 [7.5/17]	15/24 [11/20]	15/24 [11/20]	18.5/32 [15/26]	25/38 [22/38]		
		AC690V	4/5	5.5/7	7.5/9	7.5/9	11/12	11/12	15/17	22/26		
	Rated operational current / power Category AC-4 (Three-phase squirrel-cage motor load inching responsibility) [kW/A]	AC220 to 240V	1.5/8	2.2/11	3.7/18	4.5/20	5.5/26	5.5/26	7.5/35			
		AC380 to 440V	2.2/6	4/9	5.5/13	7.5/17	11/24	11/24	15/32			
		AC500V	2.7/6	5.5/9	5.5/10	7.5/12	7.5/13	11/17	15/24			
	Rated operational current / power Category AC-1 (Resistance, heater load)	AC100 to 240V	20			32			60	80		
		AC380 to 440V	11	13	13	32	32	60	80			
		AC500 to 550V	8	11	13	32	32	60	80			
Conventional Free Air Thermal Current I _{th} [A]			20			32			60	80		
Auxiliary contact rating	Contact Arrangement	Standard Accessory (Note 7)	Non-Reversing	1a	1a1b	2a2b	—	2a2b	2a2b			
		Reversing (Note 8, Note 9)	1a x 2 + 2b	1a1b x 2 + 2b	2a2b x 2	2a2b x 2	2a2b x 2	2a2b x 2				
	Max. number of additional options (Note 11)	Non-Reversing	1 for UT-AX2/4, 2 for UT-AX11									
		Reversing (Note 8, Note 9)	2 for any UT-AX2/4/11					—	2 for any UT-AX2/4/11			
	Rated Operating Current (Category AC-15: Alternating current coil load) [A]	AC120V	6	6	6	6	6	6	6			
Rated Operational Current (Category DC-13 : Direct current coil load)	DC24V	3	3	3	3	3	3	3				
	DC110V	0.6										
Conventional Free Air Thermal Current I _{th} [A]			10	10	10	10	10	10	10			
Performance	Mechanical Durability [x 10000]		1000									
	Electrical Durability (Note 5) [Ten thousand times]	Category AC-3	200 (Note 5, 6)									
		Category AC-4	3 (Note 5)									
		Category AC-1	50									
Switching Frequency [Times/Hour]	Category AC-3	1800								1200		
	Category AC-4	300										
	Category AC-1	1200										
Characteristic	Coil consumption (Note7) [VA]	Sealed	7			7		4.5	10			
		Inrush	45			75		55	110			
Power Consumption (Note 7) [W]			2.2			2.4	2.4	1.8	3.8	3.8		
Outside Dimensions	Magnetic Contactors (without Thermal Overload Relays) (Width x Height x Depth) [mm]	Non-Reversing	36 x 75 x 78	44 x 75 x 78			63 x 81 x 81		43 x 81 x 81		75 x 89 x 91	
		Reversing	82 x 85 x 78	98 x 85 x 78			136 x 81 x 81		96 x 81 x 111		160 x 114 x 97	
	Open Type Magnetic Starters (Width x Height x Depth) [mm]	Non-Reversing	46 x 115 x 79					63 x 128 x 82		—		75 x 157.5 x 91
		Reversing	90.5 x 125 x 79	98.5 x 125 x 79			136 x 138 x 82		—		160 x 179 x 97	
Enclosed Magnetic Starters (Width x Height x Depth) [mm]	Non-Reversing	76 x 165 x 97.5			—	104 x 176 x 110		—		135 x 231 x 126		
	Reversing	—			—	220 x 192 x 115		—		300 x 247 x 130		
IEC 35mm rail mounting			Possible (excluding Enclosed Magnetic Starters)									
Installable Optional Unit Model Names (Note 10)	Additional Auxiliary Contact Units	(Contact Arrangement 1a1b)	UT-AX2/AX11									
		(Contact Arrangement 2a2b)	UT-AX4									
		With Low-Level Signal Contact	—									
	Coil Surge Absorber Units (Note 4)	(Varistor) (Note 4)	UT-SA21									
		(Varistor + Display LED)	UT-SA22									
		(CR)	UT-SA23									
		(Varistor + CR)	UT-SA25									
	DC-AC Interface	Triac Output	UT-SY21									
		Contact Output	UT-SY22									
	Live Part Protection Cover	For Magnetic Starters	Non-Reversing	—								
Reversing			—									
For Magnetic Contactors		Non-Reversing	—									
		Reversing	—									
Terminal Cover	For Magnetic Starters (Non-Reversing)	(Standard Equipment)										
	For Magnetic Contactors (Non-Reversing)	(Standard Equipment)										
Mechanical Interlock Units			UT-ML20 (Note 11)			UN-ML21						

Note 1. The figure in the square brackets indicates the rated current shown on the rating plate of the product at which the category AC-3 opening/closing durability. Note 2. The value between parentheses for the rated operating current is for the magnetic starter (with thermal overload relay). Note 3. AC operated types T10 to T50, DC operated types T12 to T50 can be manufactured with coil surge absorber (□-□SA type). The UT-SA21 type can be mounted. Note 4. T65 to N800 types have an integrated coil surge absorber rendering a coil surge absorber unit for prevention of coil switching surges unnecessary. Note 5. 1 million times for T20 class AC-3 380 V or more types for the rating in parentheses and 15,000 times for class AC-4 types. 15 thousand times for T35 to N800 class AC-4 380 V or more types. Note 6. Values are for the ratings in square brackets. The electrical durability for the current values not in parentheses varies inversely with the rough square of the current. Note 7. Mechanically latched types and delay open types have differing auxiliary contact arrangements. Refer to page 102 for details about mechanically latched types, or page 111 for delay open types.

T65	T80	T100	N125	N150	N180	N220	N300	N400	N600	N800
JIS C8201-4-1, IEC60947-4-1, EN60947-4-1, GB14048.4										
S-T65	S-T80	S-T100	S-N125	S-N150	S-N180	S-N220	S-N300	S-N400	S-N600	S-N800
S-2 x T65	S-2 x T80	S-2 x T100	S-2 x N125	S-2 x N150	S-2 x N180	S-2 x N220	S-2 x N300	S-2 x N400	S-2 x N600	S-2 x N800
MS-T65	MS-T80	MS-T100	MS-N125	MS-N150	MS-N180	MS-N220	MS-N300	MS-N400	—	—
MS-2 x T65	MS-2 x T80	MS-2 x T100	MS-2 x N125	MS-2 x N150	MS-2 x N180	MS-2 x N220	MS-2 x N300	MS-2 x N400	—	—
MSO-T65	MSO-T80	MSO-T100	MSO-N125	MSO-N150	MSO-N180	MSO-N220	MSO-N300	MSO-N400	—	—
MSO-2 x T65	MSO-2 x T80	MSO-2 x T100	MSO-2 x N125	MSO-2 x N150	MSO-2 x N180	MSO-2 x N220	MSO-2 x N300	MSO-2 x N400	—	—
TH-T65	TH-T65 / T100	TH-T65 / T100	TH-N120(TA)	TH-N120(TA)	TH-N220RH	TH-N220RH	TH-N400RH	TH-N400RH	TH-N600(+CT)	TH-N600(+CT)
MS-T65KP	MS-T80KP	MS-T100KP	MS-N125KP	MS-N150KP	MS-N180KP	MS-N220KP	MS-N300KP	MS-N400KP	—	—
MS-2 x T65KP	MS-2 x T80KP	MS-2 x T100KP	MS-2 x N125KP	MS-2 x N150KP	MS-2 x N180KP	MS-2 x N220KP	MS-2 x N300KP	MS-2 x N400KP	—	—
MSO-T65KP	MSO-T80KP	MSO-T100KP	MSO-N125KP	MSO-N150KP	MSO-N180KP	MSO-N220KP	MSO-N300KP	MSO-N400KP	—	—
MSO-2 x T65KP	MSO-2 x T80KP	MSO-2 x T100KP	MSO-2 x N125KP	MSO-2 x N150KP	MSO-2 x N180KP	MSO-2 x N220KP	MSO-2 x N300KP	MSO-2 x N400KP	—	—
TH-T65KP	TH-T65 / T100KP	TH-T65 / T100KP	TH-N120(TA)KP	TH-N120(TA)KP	TH-N220RHKP	TH-N220RHKP	TH-N400RHKP	TH-N400RHKP	TH-N600KP(+CT)	TH-N600KP(+CT)
690					690 (1000)					
6					6 (8)					
50/60										
3										
18.5/65 [15/65]	22/85 [19/80]	30/105 [22/100]	37/125 [30/125]	45/150 [37/150]	55/180 [45/180]	75/250 [55/220]	90/300 [75/300]	125/400 [110/400]	190/630 [160/630]	220/800 [200/800]
30/65 [30/65]	45/85 [37/80]	55/105 [45/93]	60/120 [60/120]	75/150 [75/150]	90/180 [90/180]	132/250 [110/220]	160/300 [150/300]	220/400 [200/400]	330/630 [300/630]	440/800 [400/800]
37/60 [30/45]	45/75 [45/75]	55/85 [45/75]	60/90 [60/90]	90/140 [90/140]	110/180 [110/180]	132/200 [132/200]	160/250 [160/250]	225/350 [200/350]	330/500 [300/500]	500/720 [400/720]
30/38	45/52	55/65	60/70	90/100	110/120	132/150	200/220	250/300	330/420	500/630
11/50	15/65	19/80	22/93	30/125	37/150	45/180	55/220	75/300	110/400	160/630
22/47	30/62	37/75	45/90	55/110	75/150	90/180	110/220	150/300	200/400	300/630
22/38	30/45	37/55	45/65	55/80	75/140	90/140	110/200	150/250	200/350	300/500
100	120	150	150	200	260	260	350	450	660	800
100	120	150	150	200	260	260	350	450	660	800
100	120	150	150	200	260	260	350	450	660	800
100	120	150	150	200	260	260	350	450	660	800
2a2b	2a2b	2a2b	2a2b	2a2b	2a2b	2a2b	2a2b	2a2b	2a2b	2a2b
2a2b x 2	2a2b x 2	2a2b x 2	2a2b x 2	3a3b x 2	3a3b x 2	3a3b x 2	3a3b x 2	3a3b x 2	4a4b x 2	4a4b x 1
1 for UT-AX2/4, 2 for UT-AX11		2 for UN-AX80			2 for UN-AX150				1 for UN-AX600	
2 for any UT-AX2/4/11		2 for UN-AX80			—	—	—	—	—	—
6	6	6	6	6	6	6	6	6	6	6
3	3	3	3	3	3	3	3	3	3	3
3		3			3				3	
0.6										
10	10	10	10	10	10	10	10	10	10	10
500										
200	100 (Note 6)							50 (Note 6)		
3 (Note 5)										
50										
1200										
300										
1200		600								
20	23	24	24	40	40	50	50	90	90	
115	210	270	270	440	440	440	440	790	790	
2.2	2.2	2.8	2.9	2.9	4.2	4.2	6.1	6.1	17	
88 x 106 x 106	88 x 106 x 106	100 x 124 x 127	100 x 150 x 137	120 x 160 x 145	138 x 204 x 175	138 x 204 x 175	163 x 243 x 195	163 x 243 x 195	290 x 310 x 235	290 x 310 x 235
216 x 115 x 112	216 x 115 x 112	270 x 140 x 137	276 x 150 x 148	296 x 160 x 156	370 x 215 x 189	370 x 215 x 189	395 x 250 x 209	395 x 250 x 209	660 x 435 x 254	660 x 435 x 254
90 x 158 x 106	90 x 174.5 x 106	100 x 196 x 127	112 x 239 x 137	120 x 250 x 145	144 x 282 x 180.5	144 x 282 x 180.5	163 x 360 x 195	163 x 360 x 195	—	—
216 x 169 x 112	216 x 185.5 x 112	270 x 213 x 137	276 x 251 x 148	296 x 276 x 156	370 x 304 x 194.5	370 x 304 x 194.5	395 x 392 x 209	395 x 392 x 209	—	—
160 x 282 x 145	190 x 317 x 163	230 x 396 x 190	—	270 x 496 x 209	—	—	—	—	—	—
320 x 282 x 140	410 x 347 x 154	440 x 436 x 170	—	520 x 536 x 209	—	—	600 x 616 x 230	—	—	—
Possible (excluding Enclosed Magnetic Starters)										
UN-AX2/AX11		UN-AX80			UN-AX150				UN-AX600	
UN-AX4		—			—				—	
UN-LL22		—			—				—	
—		—			—				—	
—		—			—				—	
—		—			—				—	
UN-SY31		—			—				—	
UN-SY32		—			—				—	
UN-CZ500 + UN-CZ501		UN-CZ800+ UN-CZ801	UN-CZ1250+ UN-CZ1251	UN-CZ1500+ UN-CZ1501	UN-CZ2200 + UN-CZ2201		UN-CZ3000 + UN-CZ3001		—	—
UN-CZ504		UN-CZ804	UN-CZ1254	UN-CZ1504	UN-CZ2204		UN-CZ3004		—	—
UN-CZ500 x 2		UN-CZ800 x 2	UN-CZ1250 x 2	UN-CZ1500 x 2	UN-CZ2200 x 2		UN-CZ3000 x 2		—	—
UN-CZ502		UN-CZ802	UN-CZ1252	UN-CZ1502	UN-CZ2202		UN-CZ3002		—	—
UT-CW800 + UT-CW655		—			—				—	
UT-CW800		—			—				—	
UN-ML21		UN-ML80		UN-ML150	UN-ML220					

Note 8. The +2b on the auxiliary contact arrangement of reversible T10 to T20 types indicates the break contact of the integrated UT-ML20 interlock unit. There is no need to specify when ordering.

Note 9. Auxiliary contact arrangements for reversible types are displayed by twos, in a contact arrangement combined with two magnetic contactors. For standard contact arrangements there is no need to specify whe ordering; however, please specify a matching contact arrangement for 2 units if for a special configuration. <Example> For 1b x 2 + 2b: 2B

Note 10. Because there are products that cannot be mounted, please refer to combination details on page 192 when applying optional products.

Note 11. Not applicable to AC operated types produced before March, 2019.

2.2 Manufacturing Range List

● Non-Reversible Type

Frame		T10	T12	T20	T21	T25	T32	T35	T50	T65	T80	T100	N125	N150	N180	N220	N300	N400	N600	N800					
Category AC-3	220V	2.5	3.5	4.5	5.5	7.5	7.5	11	15	18.5	22	30	37	45	55	75	90	125	190	220					
	Rated Capacity [kW]	440V	4	5.5	7.5	11	15	15	18.5	22	30	45	55	60	75	90	132	160	220	330	440				
Auxiliary Contact (Note 6)	Standard	1a	1a1b	1a1b	←2a2b→		←2a2b→																		
	Special	1b	2a (Note 8)	2a (Note 8)	—	—	—	—	—	—	—	—	—	—	—	—	—	—	—	—	—				
Model Name																									
Magnetic Starters	Enclosed	Standard Specifications	MS-□	○	○	—	○	—	—	○	○	○	○	○	○	○	○	○	○	○	○	—	—		
		With Push-Button	MS-□PM	○	○	—	○	—	—	○	○	○	○	○	—	—	—	—	—	—	—	—	—	—	
		3-Element (2E) Thermal	MS-□KP	○	○	—	○	—	—	○	○	○	○	○	○	○	○	○	○	○	○	○	○	—	—
		Open Time Quick Motion Type	MS-□QM	—	—	—	—	—	—	—	○	○	○	○	○	○	○	○	○	○	○	○	○	—	—
	Open Type	Standard Specifications	MSO-□	○	○	○	○	○	—	○	○	○	○	○	○	○	○	○	○	○	○	○	—	—	
			MSOD-□	—	○	○	○	—	—	○	○	○	○	○	○	○	○	—	○	○	○	○	○	—	—
		3-Element (2E) Thermal	MSO-□KP	○	○	○	○	○	—	○	○	○	○	○	○	○	○	○	○	○	○	○	○	—	—
			MSOD-□KP	—	○	○	○	—	—	○	○	○	○	○	○	○	○	—	○	○	○	○	○	—	—
		With Saturable Reactor	MSO-□SR	○	○	○	○	○	—	○	○	○	○	○	○	○	○	○	○	○	○	○	○	—	—
			MSOD-□SR	—	○	○	○	—	—	○	○	○	○	○	○	○	○	—	○	○	○	○	○	—	—
		With 3-Element (2E) Thermal Saturable Reactor	MSO-□KPSR	—	—	—	○	○	—	○	○	○	○	○	○	○	○	○	○	○	○	○	○	—	—
			MSOD-□KPSR	—	—	—	○	—	—	○	○	○	○	○	○	○	—	○	○	○	○	○	○	—	—
		2-Element Quick-acting Characteristics Thermal	MSO-□FS	—	—	—	○	○	—	○	○	○	○	○	—	—	—	—	—	—	—	—	—	—	—
			MSOD-□FS	—	—	—	○	—	—	○	○	○	○	○	—	—	—	—	—	—	—	—	—	—	—
		3-Element (2E) Quick-acting Characteristics Thermal	MSO-□FSKP	○	○	○	○	○	—	○	○	○	○	○	—	—	—	—	—	—	—	—	—	—	—
			MSOD-□FSKP	—	○	○	○	—	—	○	○	○	○	○	—	—	—	—	—	—	—	—	—	—	—
		Open Time Quick Motion Type	MSO-□QM	—	—	—	—	—	—	—	—	○	○	○	○	○	○	○	○	○	○	○	○	—	—
			MSOD-□QM	—	—	—	—	—	—	—	—	○	○	○	○	○	○	○	○	○	○	○	○	—	—
		Surge Absorber Mounted Type	MSO-□SA	○	○	○	○	○	—	○	○	—	—	—	—	—	—	—	—	—	—	—	—	—	—
			MSOD-□SA	—	○	○	○	—	—	○	○	—	—	—	—	—	—	—	—	—	—	—	—	—	—
	Wiring Streamlining Terminal	MSO-□BC	○	○	○	○	○	—	○	○	—	—	—	—	—	—	—	—	—	—	—	—	—	—	
		MSOD-□BC	—	○	○	○	—	—	○	○	—	—	—	—	—	—	—	—	—	—	—	—	—	—	
	Anticorrosion Treatment	MSO-□YS	○	○	○	○	○	—	○	○	○	○	○	○	○	○	○	○	○	○	○	○	—	—	
		MSOD-□YS	—	○	○	○	—	—	○	○	○	○	○	○	○	—	○	○	○	○	○	○	—	—	
	Delay Open Type	MSO-□DL	—	○	—	○	—	—	○	○	○	○	○	—	○	—	○	○	○	○	○	○	—	—	
		MSOD-□DL	—	○	—	○	—	—	○	○	○	○	○	—	○	—	○	○	○	○	○	○	—	—	
	Mechanically Latched Type	MSOL-□	—	—	—	○	—	—	○	○	○	○	○	○	○	—	○	○	○	○	○	○	—	—	
		MSOLD-□	—	—	—	○	—	—	○	○	○	○	○	○	○	—	○	○	○	○	○	○	—	—	
With Terminal Cover	MSO-□CW	—	—	—	—	—	—	—	—	○	○	○	○	○	○	○	○	○	○	○	○	○	○		
	MSOD-□CW	—	—	—	—	—	—	—	—	○	○	○	○	○	○	○	○	○	○	○	○	○	○		
Magnetic Contactors	Open Type	Standard Specifications	S-□	○	○	○	○	○	○	○	○	○	○	○	○	○	○	○	○	○	○	○	○	○	
			SD-□	—	○	○	○	—	○	○	○	○	○	○	○	○	○	—	○	○	○	○	○	○	
		Surge Absorber Mounted Type	S-□SA(Note3)	○	○	○	○	○	○	○	○	—	—	—	—	—	—	—	—	—	—	—	—	—	—
			SD-□SA	—	○	○	○	—	○	○	○	—	—	—	—	—	—	—	—	—	—	—	—	—	—
		Anticorrosion Treatment	S-□YS	—	—	—	—	—	—	○	○	○	○	○	○	○	○	○	○	○	○	○	○	○	○
			S-□QM	—	—	—	—	—	—	—	—	○	○	○	○	○	○	○	○	○	○	○	○	—	—
		Wiring Streamlining Terminal	S-□BC	○	○	○	○	○	○	○	○	—	—	—	—	—	—	—	—	—	—	—	—	—	—
			SD-□BC	—	○	○	○	—	○	○	○	—	—	—	—	—	—	—	—	—	—	—	—	—	—
		With Spring Clamp Terminals	S-□SQ	—	○	○	—	—	—	—	—	—	—	—	—	—	—	—	—	—	—	—	—	—	—
			SD-□SQ	—	○	○	—	—	—	—	—	—	—	—	—	—	—	—	—	—	—	—	—	—	—
		With Terminal Cover	S-□CW	—	—	—	—	—	—	—	—	○	○	○	○	○	○	○	○	○	○	○	○	○	○
			SD-□CW	—	—	—	—	—	—	—	—	○	○	○	○	○	○	○	○	○	○	○	○	○	○
Delay Open Type	S-□DL	—	○	—	○	—	—	○	○	○	○	○	—	○	—	○	○	○	○	○	○	—	—		
	SD-□DL	—	○	—	○	—	—	○	○	○	○	○	—	○	—	○	○	○	○	○	○	—	—		
Mechanically Latched Type	SL-□	—	—	—	○	—	—	○	○	○	○	○	○	○	—	○	○	○	○	○	○	○	○		
	SLD-□	—	—	—	○	—	—	○	○	○	○	○	○	○	—	○	○	○	○	○	○	○	○		

● Reversible Type

Frame		2 x T10	2 x T12	2 x T20	2 x T21	2 x T25	2 x T32	2 x T35	2 x T50	2 x T65	2 x T80	2 x T100	2 x N125	2 x N150	2 x N180	2 x N220	2 x N300	2 x N400	2 x N600	2 x N800		
Category AC-3	220V	2.5	3.5	4.5	5.5	7.5	7.5	11	15	18.5	22	30	37	45	55	75	90	125	190	220		
	Rated Capacity [kW]	440V	4	5.5	7.5	11	15	15	18.5	22	30	45	55	60	75	90	132	160	220	330	440	
Auxiliary Contact (Note 4 to Note 6)	Standard	(1a x 2) + 2b	(1a1b x 2) + 2b	2a2b x 2										3a3b x 2					4a4b x 2			
	Special	(1b x 2) + 2b	(2a x 2) + 2b	-	-	-	-	-	-	-	-	-	-	-	-	-	-	-	-	-	-	
Model	Standard Specifications	MS-□	○	○	○	○	○	○	○	○	○	○	○	○	○	○	○	○	○	○	○	
Magnetic Starters	3-Element (2E) Thermal	MS-□KP	○	○	○	○	○	○	○	○	○	○	○	○	○	○	○	○	○	○	○	
	Standard Specifications	MSO-□	◎	◎	◎	◎	◎	◎	◎	◎	◎	◎	◎	◎	◎	◎	◎	◎	◎	◎	◎	
	3-Element (2E) Thermal	MSO-□KP	○	○	○	○	○	○	○	○	○	○	○	○	○	○	○	○	○	○	○	○
		MSOD-□KP	○	○	○	○	○	○	○	○	○	○	○	○	○	○	○	○	○	○	○	○
	With Saturable Reactor	MSO-□SR	○	○	○	○	○	○	○	○	○	○	○	○	○	○	○	○	○	○	○	○
		MSOD-□SR	○	○	○	○	○	○	○	○	○	○	○	○	○	○	○	○	○	○	○	○
	With 3-Element (2E) Thermal Saturable Reactor	MSO-□KPSR	○	○	○	○	○	○	○	○	○	○	○	○	○	○	○	○	○	○	○	○
		MSOD-□KPSR	○	○	○	○	○	○	○	○	○	○	○	○	○	○	○	○	○	○	○	○
	2-Element Quick-acting Characteristics Thermal	MSO-□FS	○	○	○	○	○	○	○	○	○	○	○	○	○	○	○	○	○	○	○	○
		MSOD-□FS	○	○	○	○	○	○	○	○	○	○	○	○	○	○	○	○	○	○	○	○
	3-Element (2E) Quick-acting Characteristics Thermal	MSO-□FSKP	○	○	○	○	○	○	○	○	○	○	○	○	○	○	○	○	○	○	○	○
		MSOD-□FSKP	○	○	○	○	○	○	○	○	○	○	○	○	○	○	○	○	○	○	○	○
	Surge Absorber Mounted Type	MSO-□SA	○	○	○	○	○	○	○	○	○	○	○	○	○	○	○	○	○	○	○	○
		MSOD-□SA	○	○	○	○	○	○	○	○	○	○	○	○	○	○	○	○	○	○	○	○
	Wiring Streamlining Terminal	MSO-□BC	○	○	○	○	○	○	○	○	○	○	○	○	○	○	○	○	○	○	○	○
		MSOD-□BC	○	○	○	○	○	○	○	○	○	○	○	○	○	○	○	○	○	○	○	○
	With Terminal Cover	MSO-□CW	○	○	○	○	○	○	○	○	○	○	○	○	○	○	○	○	○	○	○	○
		MSOD-□CW	○	○	○	○	○	○	○	○	○	○	○	○	○	○	○	○	○	○	○	○
	Anticorrosion Treatment	MSO-□YS	○	○	○	○	○	○	○	○	○	○	○	○	○	○	○	○	○	○	○	○
		MSOD-□YS	○	○	○	○	○	○	○	○	○	○	○	○	○	○	○	○	○	○	○	○
Mechanically Latched Type	MSOL-□	○	○	○	○	○	○	○	○	○	○	○	○	○	○	○	○	○	○	○	○	
	MSOLD-□	○	○	○	○	○	○	○	○	○	○	○	○	○	○	○	○	○	○	○	○	
Magnetic Contactors	Standard Specifications	S-□	◎	◎	◎	◎	◎	◎	◎	◎	◎	◎	◎	◎	◎	◎	◎	◎	◎	◎	◎	
	Surge Absorber Mounted Type	SD-□	○	○	○	○	○	○	○	○	○	○	○	○	○	○	○	○	○	○	○	○
		S-□SA(Note 3)	○	○	○	○	○	○	○	○	○	○	○	○	○	○	○	○	○	○	○	○
	Anticorrosion Treatment	SD-□SA	○	○	○	○	○	○	○	○	○	○	○	○	○	○	○	○	○	○	○	○
		S-□YS	○	○	○	○	○	○	○	○	○	○	○	○	○	○	○	○	○	○	○	○
	Wiring Streamlining Terminal	S-□BC	○	○	○	○	○	○	○	○	○	○	○	○	○	○	○	○	○	○	○	○
		SD-□BC	○	○	○	○	○	○	○	○	○	○	○	○	○	○	○	○	○	○	○	○
	With Terminal Cover	S-□CW	○	○	○	○	○	○	○	○	○	○	○	○	○	○	○	○	○	○	○	○
		SD-□CW	○	○	○	○	○	○	○	○	○	○	○	○	○	○	○	○	○	○	○	○
	Mechanically Latched Type	SL-□	○	○	○	○	○	○	○	○	○	○	○	○	○	○	○	○	○	○	○	○
		SLD-□	○	○	○	○	○	○	○	○	○	○	○	○	○	○	○	○	○	○	○	○
	Class 2 Heat Resistance	S-□FN	○	○	○	○	○	○	○	○	○	○	○	○	○	○	○	○	○	○	○	○
	With Reversing Connecting Conductor (Both Power and Load Sides)	S-□SD	○	○	○	○	○	○	○	○	○	○	○	○	○	○	○	○	○	○	○	○
		SD-□SD	○	○	○	○	○	○	○	○	○	○	○	○	○	○	○	○	○	○	○	○
	With Power Side 3-Pole In-Phase Crossover Conductor	S-□SG	○	○	○	○	○	○	○	○	○	○	○	○	○	○	○	○	○	○	○	○
		SD-□SG	○	○	○	○	○	○	○	○	○	○	○	○	○	○	○	○	○	○	○	○
	With Load Side 3-Pole In-Phase Crossover Conductor	S-□SX	○	○	○	○	○	○	○	○	○	○	○	○	○	○	○	○	○	○	○	○
		SD-□SX	○	○	○	○	○	○	○	○	○	○	○	○	○	○	○	○	○	○	○	○
	With Load Side 3-Pole Reverse-Phase Switching Crossover Conductor	S-□SF	○	○	○	○	○	○	○	○	○	○	○	○	○	○	○	○	○	○	○	○
		SD-□SF	○	○	○	○	○	○	○	○	○	○	○	○	○	○	○	○	○	○	○	○

- Note 1. ◎ : Permanently in stock, depending on operation coil voltage and heater designation. ○ : Made to order.
- : Outside production range
- Note 2. The value between parentheses for the class AC-3 rated capacity applies to an enclosed magnetic starter.
- Note 3. T65 to N800 types have an AC control coil integrated surge absorber, rendering a coil surge absorber unit for prevention of coil switching surges unnecessary.
- Note 4. The +2b on the auxiliary contact arrangement of reversible T10 to T20 types indicates the break contact of the integrated UT-ML20 interlock unit. There is no need to specify when ordering.
- Note 5. Auxiliary contact arrangements for reversible types are displayed by twos, in a contact arrangement combining two magnetic contactors. For standard contact arrangements there is no need to specify when ordering; however, please specify a matching contact arrangement for 2 units if for a special configuration.
<Example> For 1b x 2 + 2b: 2B
- Note 6. Mechanically latched types and delay open types have differing auxiliary contact arrangements. Refer to page 102 for details about mechanically latched types, or page 111 for delay open types.
- Note 7. MSO(D)-(2x)T80CW(KP) heater designation 67A is not manufactured.
- Note 8. S-T12/T20 auxiliary contact 2b can be manufactured.

4.1 MS/MSO/S-□ Standard (AC Operated) Magnetic Starters/Magnetic Contactors

A high quality product that supports the various needs of our customers on a global scale.

- Usable in general applications such as motor starting, stopping, and burnout protection.
- Adopts twin contacts for the auxiliary contacts across all series for high reliability.
- Our standard products comply with the domestic standards as well as various overseas standards and are certified as meeting all standards. (Refer to page 266 for details.)

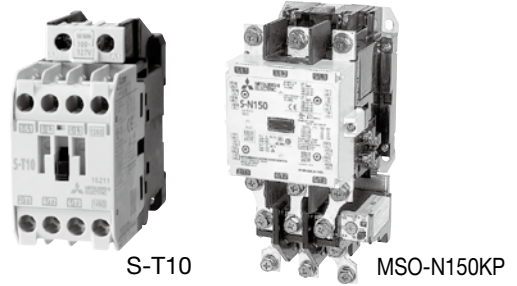

● Ratings/Specifications (Standard Applicability)

Magnetic Contactors	Magnetic Starters (Note 12)	Rated Capacity [kW]				Rated Operating Current [A]				Conventional Free Air Thermal Current [A]	Auxiliary Contact		Compatible Thermal Overload Relays			
		Three-Phase Squirrel-cage Motor (Category AC-3)				Three-Phase Squirrel-cage Motor (Category AC-3)					Resistive Load (Category AC-1)		Standard (Special)	Additional Unit Model Names x Pieces	Model Name	Heater Designation Range [A]
		AC220 to 240 V	AC380 to 440 V	AC500 V	AC690 V	AC220 to 240 V	AC380 to 440 V	AC500 V	AC690 V		AC100 to 240 V	AC380 to 440 V				
S-T10(BC)	MSO-T10(BC)KP	2.5[2.2]	4[2.7]	4[2.7]	4	11[11]	9[7]	7[6]	5	20	11	20	1a(1b)		0.12 to 9	
S-T12(BC)	MSO-T12(BC)KP	3.5[2.7]	5.5[4]	5.5[5.5]	5.5	13[13]	12[9]	9[9]	7	20	13	20	1a1b (2a, 2b)	TH-T18(BC)KP	0.12 to 11 0.12 to 15	
S-T20(BC)	MSO-T20(BC)KP	4.5[3.7]	7.5[7.5]	7.5[7.5]	7.5	18[18]	18[18]	17[17]	9	20	18	20	2a2b		0.24 to 22	
S-T21(BC)	MSO-T21(BC)KP	5.5[4] (Note 3)	11[7.5]	11[7.5]	7.5	25[20]	23[20]	17[17]	9	32	32	32	2a2b		0.24 to 22	
S-T25(BC)	MSO-T25(BC)KP	7.5 [5.5]	15[11]	15[11]	11	30[26] (Note 1)	30[26] (Note 1)	24[20]	12	32	32	32	2a2b	UT-AX2, 4(BC) x 1 or UT-AX11(BC) x 2	TH-T25(BC)KP	0.24 to 22
S-T32(BC)	—	7.5 [7.5]	15[15]	15[11]	11	32[32]	32[32]	24[20]	12	32	32	32	—	—	—	
S-T35(BC)	MSO-T35(BC)KP	11[7.5]	18.5[15]	18.5[15]	15	40[35]	40[32]	32[26]	17	60	60	60		TH-T25(BC)KP	0.24 to 22	
S-T50(BC)	MSO-T50(BC)KP	15[11]	22[22]	25[22]	22	55[50] (Note 1)	50[48]	38[38]	26	80	80	80		TH-T50(BC)KP	29	
S-T65(CW)	MSO-T65(CW)KP	18.5[15]	30[30]	37[30]	30	65[65]	65[65]	60[45]	38	100	100	100		TH-T25(BC)KP	0.24 to 22	
S-T80(CW)	MSO-T80(CW)KP (Note 10)	22[19]	45[37]	45[45]	45	85[80]	85[80]	75[75]	52	120	120	120		TH-T50(BC)KP	29 to 42	
S-T100	MSO-T100KP	30[22]	55[45]	55[45]	55	105[100]	105[93]	85[75]	65	150	150	150	2a2b	UN-AX2, 4 x 1 or UN-AX11 x 2	TH-T65KP	15 to 54
S-N125	MSO-N125KP	37[30]	60[60]	60[60]	60	125[125]	120[120]	90[90]	70	150	150	150		TH-T100KP (Note 4)	67	
S-N150	MSO-N150KP	45[37]	75[75]	90[90]	90	150[150]	150[150]	140[140]	100	200	200	200		TH-T65KP	15 to 54	
S-N180	MSO-N180KP	55[45]	90[90]	110[110]	110	180[180]	180[180]	180[180]	120	260	260	260		TH-T100KP	67, 82	
S-N220	MSO-N220KP	75[55]	132[110]	132[132]	132	250[220]	250[220]	200[200]	150	260	260	260		TH-N120KP (TA)	42 to 105	
S-N300	MSO-N300KP	90[75]	160[150]	160[160]	200	300[300]	300[300]	250[250]	220	350	350	350		TH-N220KPRH	82 to 150	
S-N400	MSO-N400KP	125[110]	220[200]	225[200]	250	400[400]	400[400]	350[350]	300	450	450	450		TH-N400KPRH	105 to 250 105 to 330	
S-N600	—	190[160]	330[300]	330[300]	330	630[630]	630[630]	500[500]	420	660	660	660		TH-N600KP	250 to 500	
S-N800	—	220[200]	440[400]	500[400]	500	800[800]	800[800]	720[720]	630	800	800	800		TH-N600KP (Note 5)	250 to 660	

- Note 1. The value in parentheses for the rated operating current is applicable in the case of magnetic contactors.
- Note 2. Enclosed type magnetic starters are of MS-□ type. T20, T25, T32 and N600, N800 types are outside production range. It should be noted that auxiliary contact units cannot be additionally installed to enclosed types. MS-T□DP is for single-phase motors. Refer to page 267 article 10.3 for details about production range or applicable capacities.
- Note 3. MS-T21 type with 200 to 220 V ratings are 3.7 kW, in accordance with the Electrical Appliance and Material Safety Law.
- Note 4. Enclosed type heater designation 67A uses a thermal overload relay dedicated for enclosed types.
- Note 5. Please use TH-N600 in combination with a separately sold current transformer (Mitsubishi CW-□).
- Note 6. Refer to page 51 for information regarding application to resistive loads and capacitive loads.
- Note 7. The main contact minimum operating voltage and current differ depending on the allowable fault rate. Refer to page 42 for details.
- Note 8. "BC" in the model name refers to "wiring streamlining terminal".
- Note 9. T65 to T100 and N125 to N800 are AC operated, DC energizing types, which may become unusable or undergo property alteration depending on the control circuit conditions. Carefully read page 71 before use.
- Note 10. MSO-T80CW heater designation 67A is not manufactured.
- Note 11. MSO-T□ and MSO-N□ types can also be manufactured.
- Note 12. S-T12 and S-T20 with spring clamp terminals (SQ) can also be manufactured.

Item	Reference Page	Remarks
· Main Contact Rating	Page 39	—
· Auxiliary Contact Rating	Page 41	—
· Operation Coil	Page 43	—
· Properties	Page 45	—
· Performance	Page 46	—
· Outline Drawings/Contact Arrangements	Page 77	—
· How to Order	Page 130	—
· Combining with Optional Units	Page 194	—

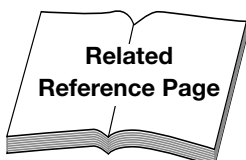

4.2 MS/MSO/S-2x□ Reversible Magnetic Starters/ Magnetic Contactors

Ideal for forward/reverse operation of AC motors

- Ideal for forward rotation, reverse rotation, or plugging, as well as for the switching of normal and emergency power supplies.
- A highly reliable mechanical interlock is equipped as standard.



MSO-2xT21KP

● Ratings/Specifications (Standard Applicability)

Magnetic Contactors	Magnetic Starters (Note 12)	Rated Capacity [kW]				Rated Operating Current [A]						Conventional Free Air Thermal Current Ith [A]	Auxiliary Contact		Compatible Thermal Overload Relays	
		Three-Phase Squirrel-cage Motor (Category AC-3)				Three-Phase Squirrel-cage Motor (Category AC-3)				Resistive Load (Category AC-1)			Standard (Special)	Additional Unit Model Names x Pieces	Model Name	Heater Designation Range [A]
		AC220 to 240 V	AC380 to 440 V	AC500 V	AC690 V	AC220 to 240 V	AC380 to 440 V	AC500 V	AC690 V	AC100 to 240 V	AC380 to 440 V					
S-2xT10(BC)	MSO-2xT10(BC)KP	2.5[2.2]	4[2.7]	4[2.7]	4	11[11]	9[7]	7[6]	5	20	11	20	1a x 2 + 2b (1b x 2 + 2b)			0.12 to 9
S-2xT12(BC)	MSO-2xT12(BC)KP	3.5[2.7]	5.5[4]	5.5[5.5]	5.5	13[13]	12[9]	9[9]	7	20	13	20	1a1b x 2 + 2b (2a x 2 + 2b)		TH-T18(BC)KP	0.12 to 11
S-2xT20(BC)	MSO-2xT20(BC)KP	4.5[3.7]	7.5[7.5]	7.5[7.5]	7.5	18[18]	18[18]	17[17]	9	20	18	20	1a1b x 2 + 2b (2a x 2 + 2b)	UT-AX2, 4(BC) x 2 or UT-AX11(BC) x 2		0.12 to 15
S-2xT21(BC)	MSO-2xT21(BC)KP	5.5[4] (Note 3)	11[7.5]	11[7.5]	7.5	25[20]	23[20]	17[17]	9	32	32	32			TH-T25(BC)KP	0.24 to 22
S-2xT25(BC)	MSO-2xT25(BC)KP	7.5[5.5]	15[11]	15[11]	11	30[26][26] (Note 1)	30[26][25] (Note 1)	24[20]	12	32	32	32				0.24 to 22
S-2xT32(BC)	—	7.5[7.5]	15[15]	15[11]	11	32[32]	32[32]	24[20]	12	32	32	32		—	—	—
S-2xT35(BC)	MSO-2xT35(BC)KP	11[7.5]	18.5[15]	18.5[15]	15	40[35]	40[32]	32[26]	17	60	60	60			TH-T25(BC)KP	0.24 to 22
S-2xT50(BC)	MSO-2xT50(BC)KP	15[11]	22[22]	25[22]	22	55[50][50] (Note 1)	50[48]	38[38]	26	80	80	80	2a2b x 2	UT-AX2, 4(BC) x 2 or UT-AX11(BC) x 2	TH-T50(BC)KP	0.24 to 22
S-2xT65(CW)	MSO-2xT65(CW)KP	18.5[15]	30[30]	37[30]	30	65[65]	65[65]	60[45]	38	100	100	100			TH-T50(BC)KP	29 to 42
S-2xT80(CW)	MSO-2xT80(CW)KP (Note 11)	22[19]	45[37]	45[45]	45	85[80]	85[80]	75[75]	52	120	120	120		UN-AX2, 4 x 2 or UN-AX11 x 2	TH-T65KP	15 to 54
S-2xT100	MSO-2xT100KP	30[22]	55[45]	55[45]	55	105[100]	105[93]	85[75]	65	150	150	150			TH-T100KP	67
S-2xN125	MSO-2xN125KP	37[30]	60[60]	60[60]	60	125[125]	120[120]	90[90]	70	150	150	150			TH-T65KP	15 to 54
S-2xN150	MSO-2xN150KP	45[37]	75[75]	90[90]	90	150[150]	150[150]	140[140]	100	200	200	200			TH-T100KP	67, 82
S-2xN180	MSO-2xN180KP	55[45]	90[90]	110[110]	110	180[180]	180[180]	180[180]	120	260	260	260			TH-T100KP	67, 82
S-2xN220	MSO-2xN220KP	75[55]	132[110]	132[132]	132	250[220]	250[220]	200[200]	150	260	260	260	3a3b x 2	—	TH-N120KP	42 to 105
S-2xN300	MSO-2xN300KP	90[75]	160[150]	160[160]	200	300[300]	300[300]	250[250]	220	350	350	350			(TA)	42 to 125
S-2xN400	MSO-2xN400KP	125[110]	220[200]	225[200]	250	400[400]	400[400]	350[350]	300	450	450	450			TH-N220KPRH	82 to 180
S-2xN600	—	190[160]	330[300]	330[300]	330	630[630]	630[630]	500[500]	420	660	660	660			TH-N400KPRH	105 to 250
S-2xN800	—	220[200]	440[400]	500[400]	500	800[800]	800[800]	720[720]	630	800	800	800	4a4b x 2	—	TH-N600KP	250 to 500
															(Note 5)	250 to 660

Note 1. The value in parentheses for the rated operating current is applicable in the case of magnetic contactors.

Note 2. Enclosed type magnetic starters are of MS-2x□ type. T10, T12, T20, T25, T32 and N600, N800 types are outside production range. It should be noted that auxiliary contact units cannot be additionally installed to enclosed types.

Note 3. MS-2 x T21 types with 200 to 220 V ratings are 3.7 kW, in accordance with the Electrical Appliance and Material Safety Law.

Note 4. Enclosed type heater designation 67A uses a thermal overload relay dedicated for enclosed types.

Note 5. Please use TH-N600 in combination with a separately sold current transformer (Mitsubishi CW-□).

Note 6. Refer to page 51 for information regarding application to resistive loads and capacitive loads.

Note 7. The main contact minimum operating voltage and current differ depending on the allowable fault rate. Refer to page 42 for details.

Note 8. The +2b on the auxiliary contact arrangement of reversible T10, T12 and T20 types indicates the break contact of the integrated UT-ML20 interlock unit. There is no need to specify when ordering.

Note 9. Auxiliary contact arrangements are displayed by twos, in a contact arrangement combined with two magnetic contactors. For standard contact arrangements there is no need to specify when ordering; however, please specify a matching contact arrangement for 2 units if for a special configuration. <Example> 1b x 2 + 2b: 2B, 2a x 2 + 2b: 4A

Note 10. "BC" in the model name refers to "wiring streamlining terminal".

Note 11. MSO-2xT80CW heater designation 67A is not manufactured.

Note 12. MSO-2xT□ and MSO-2xN□ types can also be manufactured.

● Connecting Conductor Included

Standard reversible magnetic contactors do not have a connecting conductor installed on the main circuit; however, products with connecting conductors (3-pole) on the main circuit can be manufactured. The 4 types below are available. (For information on whether an additional thermal overload relay can be connected, refer to page 216.)

- (1) Mountable on Both Power/Load Side ... For Reversing Operation : S-2xT□SD, S-2xN□SD
- (2) Mountable Only on Power Side (3-Pole In-Phase) ... For 2 Load Circuits : S-2xT□SG, S-2xN□SG
- (3) Mountable Only on Load Side (3-Pole In-Phase) ... For 2 Power Systems : S-2xT□SX, S-2xN□SX
- (4) Mountable Only on Load Side (Reverse Phase Switchable) : S-2xT□SF, S-2xN□SF

Note 1. If a connecting conductor is required, refer to page 216 to order a main circuit conductor kit.

● Connecting Conductor Wiring Diagram

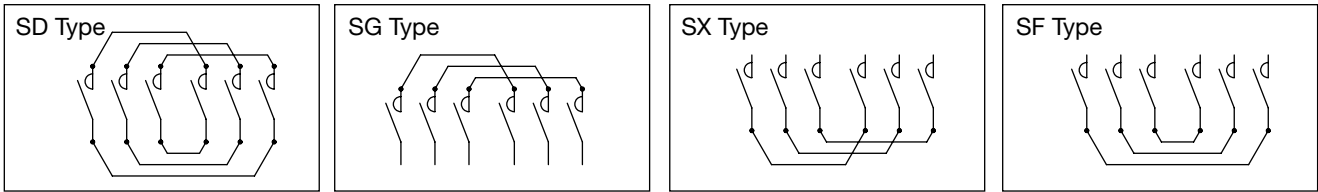

● Structure/Operation

● Structure

- (1) MSO-2 × T□, S-2 × T□ and MSO-2 × N□ types have the same mounting pitch as S-2 × N□ types.
- (2) Reversible MSO/S-2xT10 to T25 types can be mounted to IEC 35 mm rails as-is, while T35 to T80 types can be mounted by removing the mounting plate.

● Operation

(1) Open State (Fig. 1, 2(a), 3(a))

When both the left and right contactors are in the OFF state, the lever tip is retained in the open state via the return spring.

(2) Closed State (Fig. 2(b) and Fig. 3(b))

When the contactor of one side is energized (closed), the cross bar causes the lever pin (or lever system) to be pushed downward, rotating the interlock lever so that the lever tips cross each other.

When this happens, even if an energizing operation is attempted on the other contactor, as the lever tips are crossed over the operation will be prevented.

(3) Opening

When the energizing current to a contact on one side is halted, the cross bar returns to its original state via the contactor tripping spring. This action of the cross bar raises the interlock lever with the help of the return spring, returning the interlock lever to its correct position.

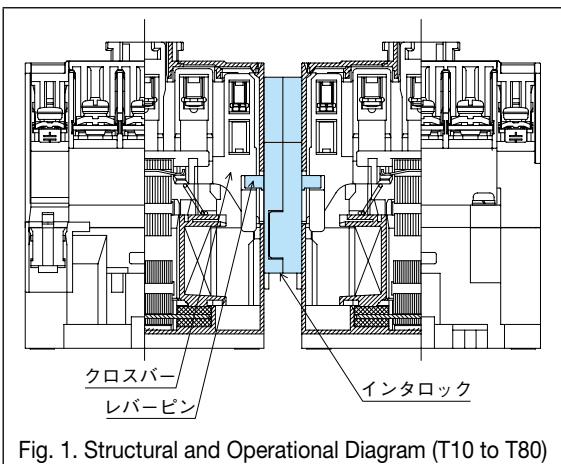

Fig. 1. Structural and Operational Diagram (T10 to T80)

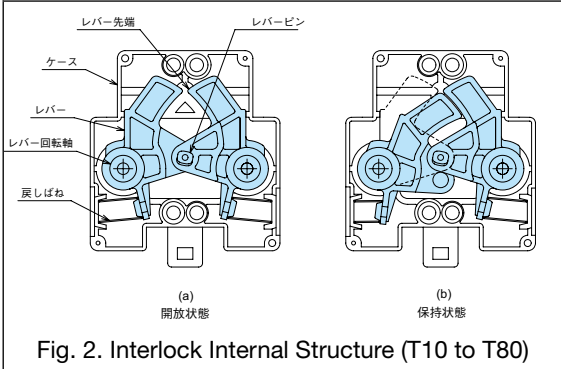
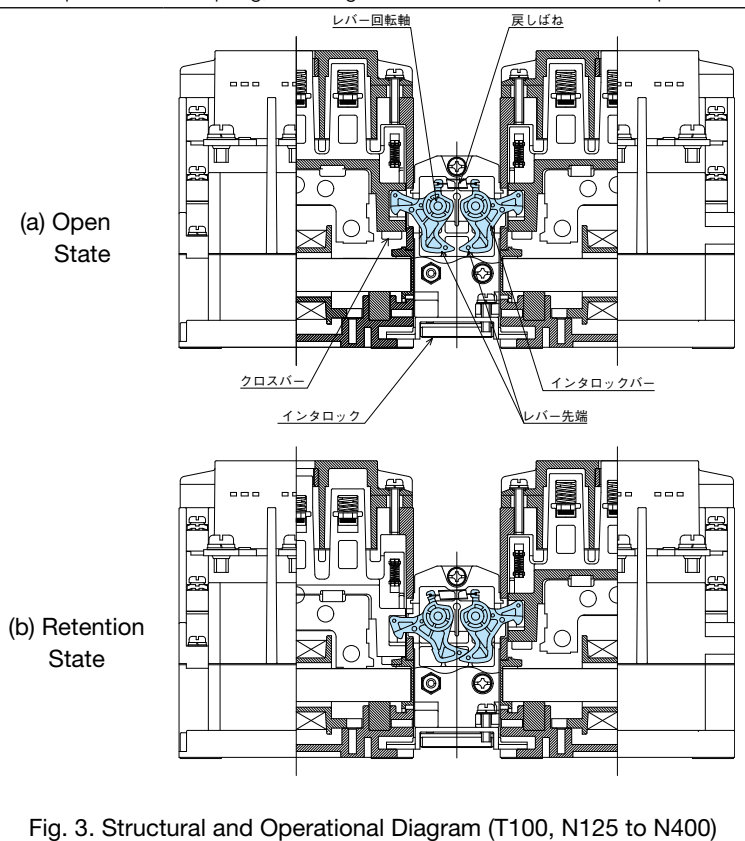

Fig. 2. Interlock Internal Structure (T10 to T80)



(a) Open State

(b) Retention State

Fig. 3. Structural and Operational Diagram (T100, N125 to N400)

● Handling

- (1) Be sure to release the electrical interlock via the break contact of the left and right magnetic contactors.
- (2) The electrical interlock uses the break contact on the inner side (the mechanical interlock side).
- (3) Horizontal mounting of the product is not available.

	Item	Reference Page	Remarks
	・ Main Contact Rating	Page 39	—
	・ Auxiliary Contact Rating	Page 41	—
	・ Operation Coil	Page 43	—
	・ Properties	Page 45	—
	・ Performance	Page 46	—
	・ Outline Drawings/Contact Arrangements	Page 77	—
	・ How to Order	Page 130	—
	・ Combining with Optional Units	Page 194	—

● Outline Drawings/Contact Arrangements (AC Operated Magnetic Starters/Magnetic Contactors)
 ■ T10 (The diagrams show models without "BC".)

Non-Reversing
MSO-T10(BC)KP

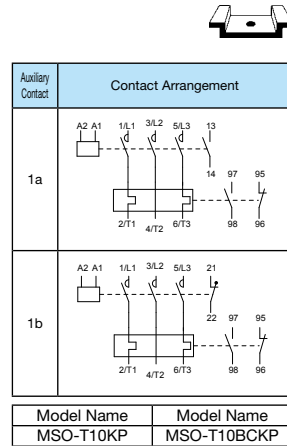
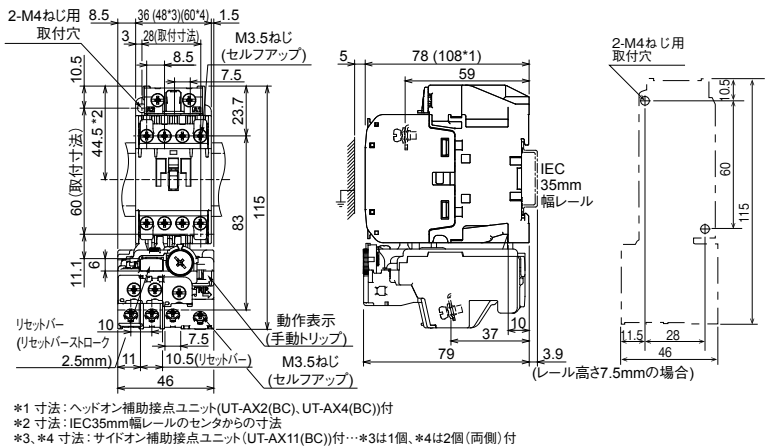

Reversing
MSO-2 x T10(BC)KP

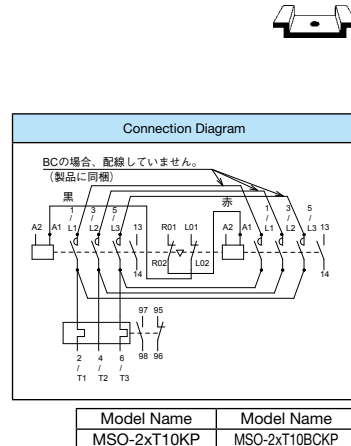
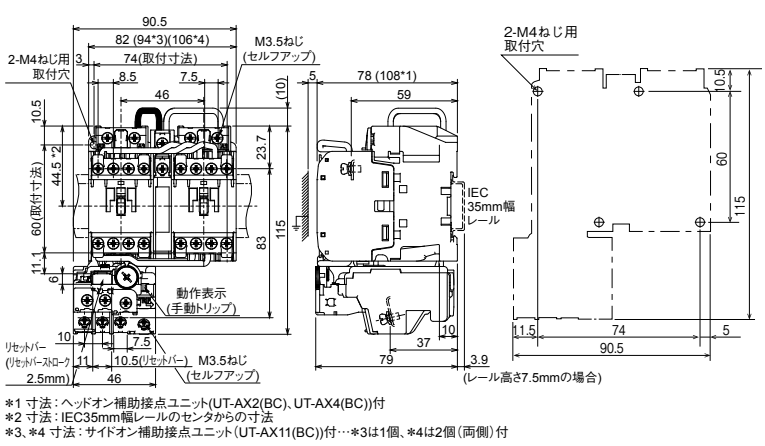

Non-Reversing
S-T10(BC)

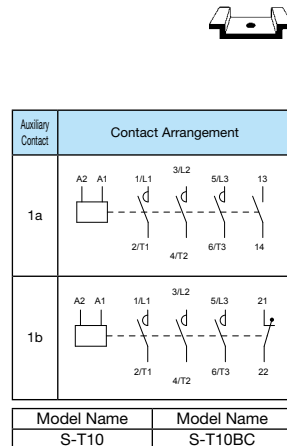
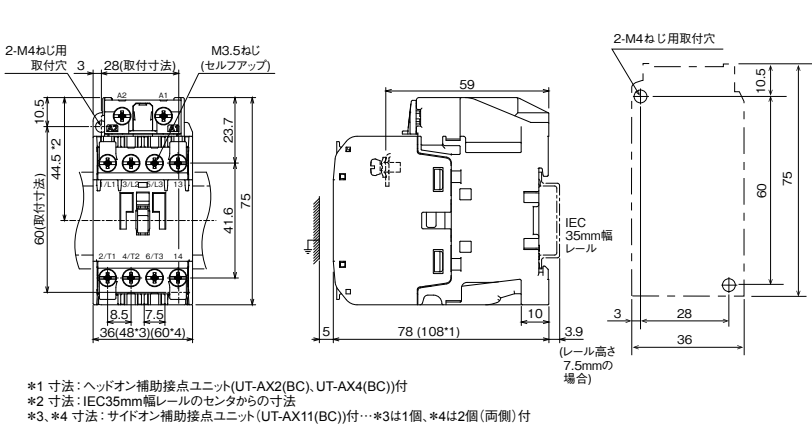
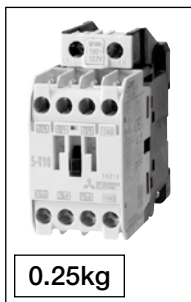

Reversing
S-2 x T10(BC)

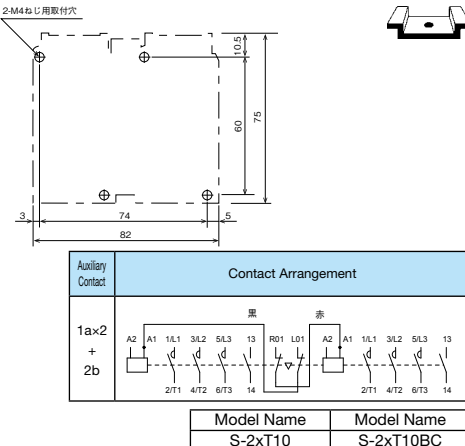
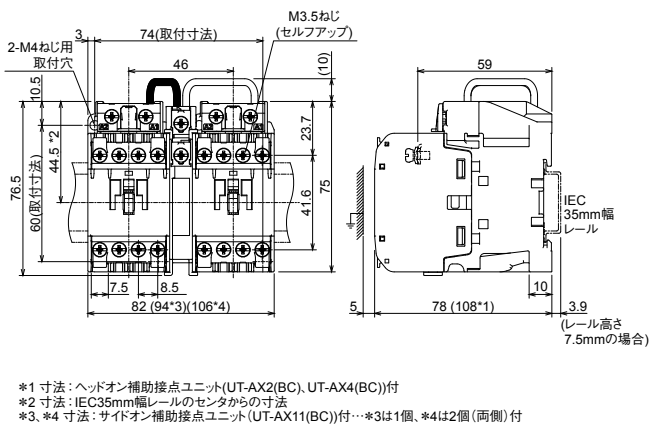
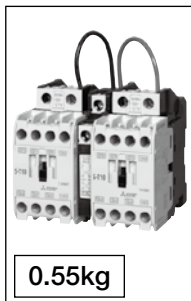

4 MS-T/N Series Magnetic Starters/Magnetic Contactors

T12/T20 (The diagrams show models without "BC".)

Non-Reversing

MSO-T12(BC)KP
MSO-T20(BC)KP

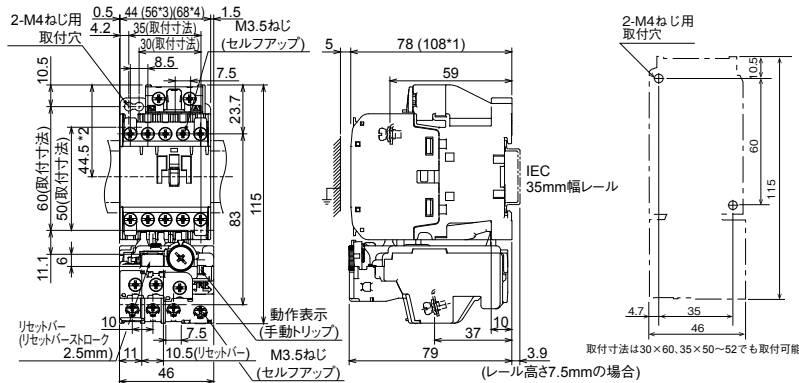

*1 寸法: ヘッドオン補助接点ユニット(UT-AX2(BC), UT-AX4(BC))付
*2 寸法: IEC35mm幅レールのセンターからの寸法
*3, *4 寸法: サイドオン補助接点ユニット(UT-AX11(BC))付... *3は1個, *4は2個(両側)付

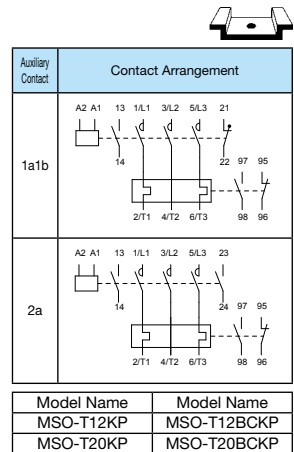

Reversing

MSO-2xT12(BC)KP
MSO-2xT20(BC)KP

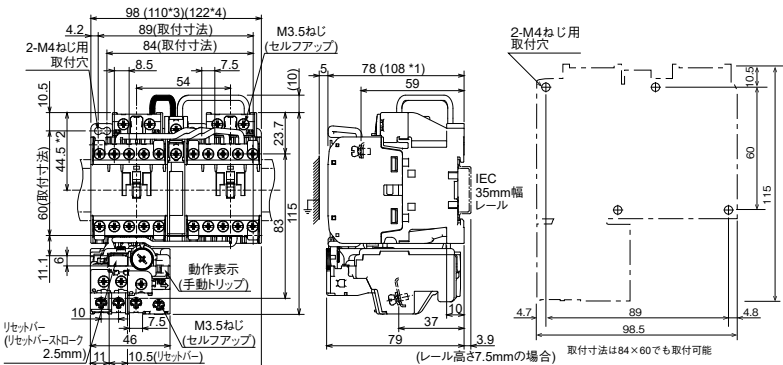
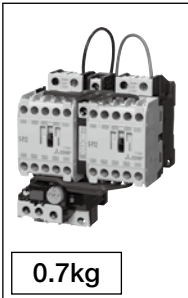

*1 寸法: ヘッドオン補助接点ユニット(UT-AX2(BC), UT-AX4(BC))付
*2 寸法: IEC35mm幅レールのセンターからの寸法
*3, *4 寸法: サイドオン補助接点ユニット(UT-AX11(BC))付... *3は1個, *4は2個(両側)付

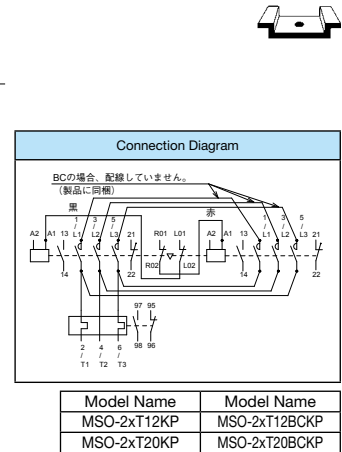

Non-Reversing

S-T12(BC)
S-T20(BC)

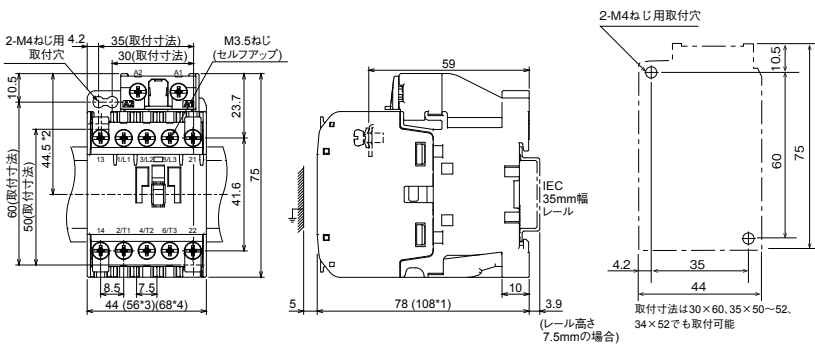
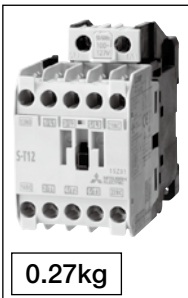

*1 寸法: ヘッドオン補助接点ユニット(UT-AX2(BC), UT-AX4(BC))付
*2 寸法: IEC35mm幅レールのセンターからの寸法
*3, *4 寸法: サイドオン補助接点ユニット(UT-AX11(BC))付... *3は1個, *4は2個(両側)付

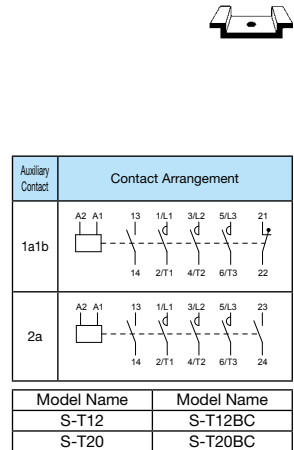

Reversing

S-2xT12(BC)
S-2xT20(BC)

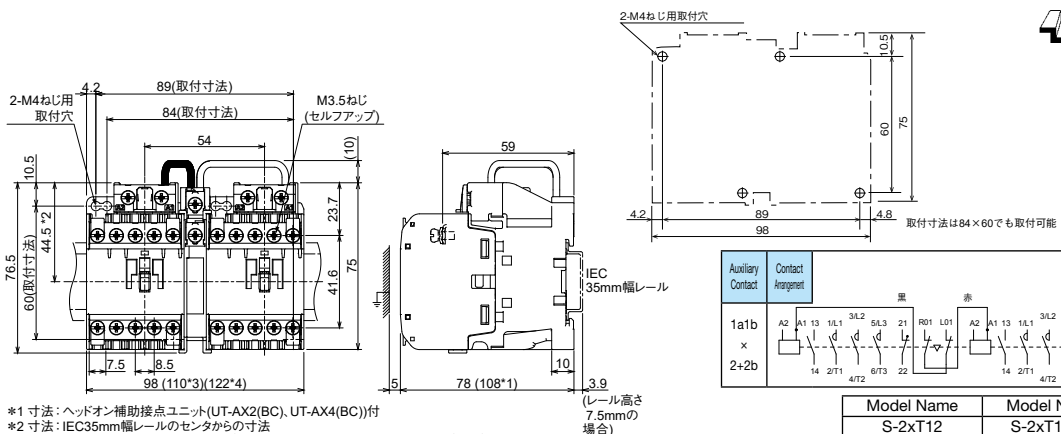
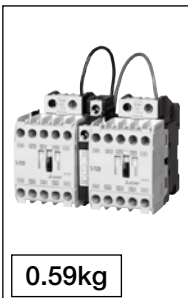

*1 寸法: ヘッドオン補助接点ユニット(UT-AX2(BC), UT-AX4(BC))付
*2 寸法: IEC35mm幅レールのセンターからの寸法
*3, *4 寸法: サイドオン補助接点ユニット(UT-AX11(BC))付... *3は1個, *4は2個(両側)付

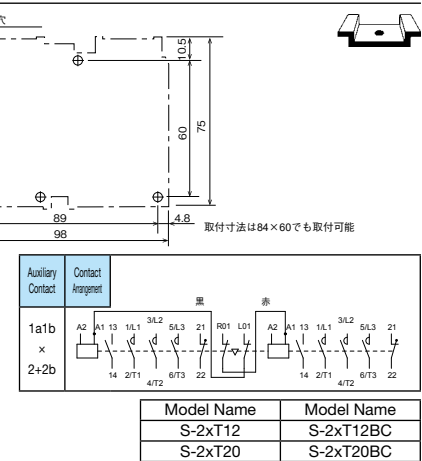

T21/T25 (The diagrams show models without "BC".)

Non-Reversing

MSO-T21(BC)KP
MSO-T25(BC)KP



0.58 kg

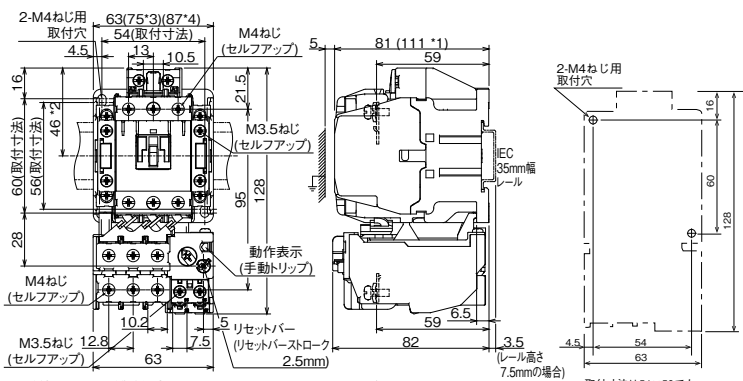

- *1 寸法: ヘッドオン補助接点ユニット(UT-AX2(BC), UT-AX4(BC))付
- *2 寸法: IEC35mm幅レールのセンタからの寸法
- *3, *4 寸法: サイドオン補助接点ユニット(UT-AX11(BC))付... *3は1個, *4は2個(両側)付

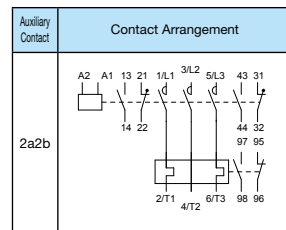

Model Name	Model Name
MSO-T21KP	MSO-T21BCKP
MSO-T25KP	MSO-T25BCKP

Reversing

MSO-2xT21(BC)KP
MSO-2xT25(BC)KP

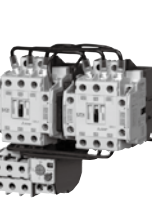

1.03 kg

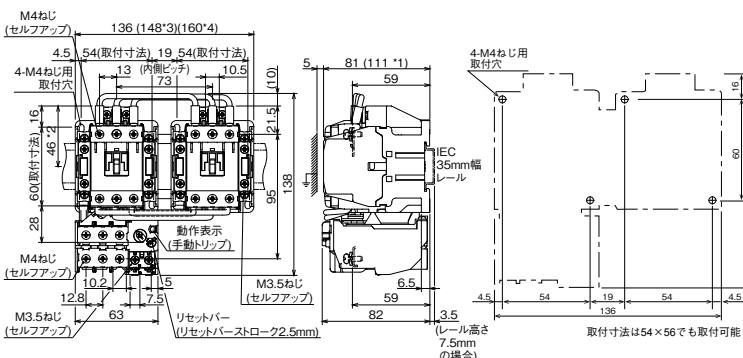

- *1 寸法: ヘッドオン補助接点ユニット(UT-AX2(BC), UT-AX4(BC))付
- *2 寸法: IEC35mm幅レールのセンタからの寸法
- *3, *4 寸法: サイドオン補助接点ユニット(UT-AX11(BC))付... *3は1個, *4は2個(両側)付

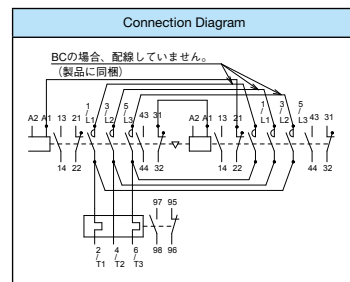

Model Name	Model Name
MSO-2xT21KP	MSO-2xT21BCKP
MSO-2xT25KP	MSO-2xT25BCKP

Non-Reversing

S-T21(BC)
S-T25(BC)



0.41 kg

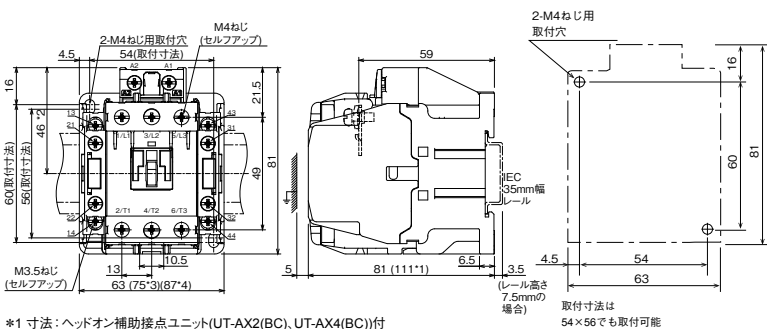

- *1 寸法: ヘッドオン補助接点ユニット(UT-AX2(BC), UT-AX4(BC))付
- *2 寸法: IEC35mm幅レールのセンタからの寸法
- *3, *4 寸法: サイドオン補助接点ユニット(UT-AX11(BC))付... *3は1個, *4は2個(両側)付

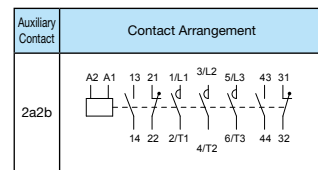

Model Name	Model Name
S-T21	S-T21BC
S-T25	S-T25BC

Reversing

S-2 x T21(BC)
S-2 x T25(BC)



0.86 kg

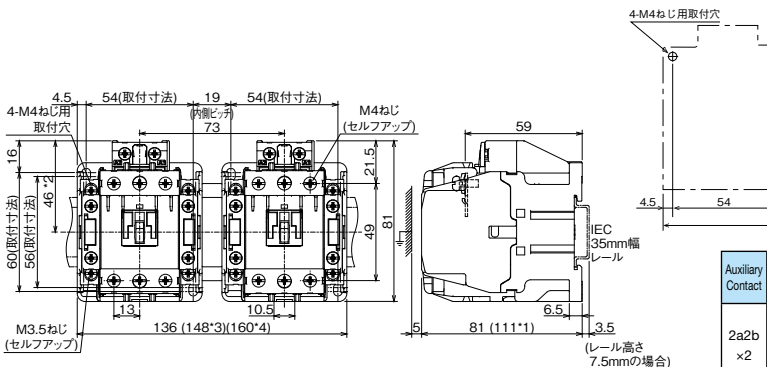

- *1 寸法: ヘッドオン補助接点ユニット(UT-AX2(BC), UT-AX4(BC))付
- *2 寸法: IEC35mm幅レールのセンタからの寸法
- *3, *4 寸法: サイドオン補助接点ユニット(UT-AX11(BC))付... *3は1個, *4は2個(両側)付

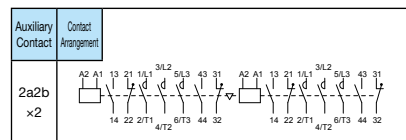

Model Name	Model Name
S-2xT21	S-2xT21BC
S-2xT25	S-2xT25BC

■ T32 (The diagrams show models without "BC".)

Non-Reversing

S-T32(BC)

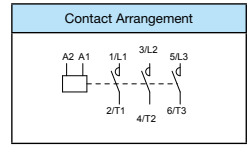
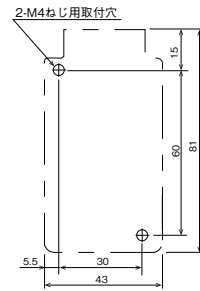
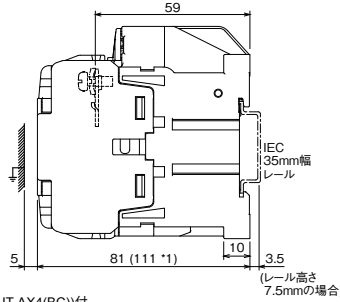
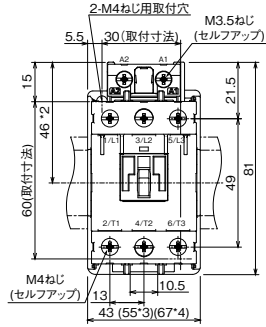

Model Name
S-T32
S-T32BC

*1 寸法:ヘッドオン補助接点ユニット(UT-AX2(BC), UT-AX4(BC))付
 *2 寸法:IEC35mm幅レールのセンタからの寸法
 *3, *4 寸法:サイドオン補助接点ユニット(UT-AX11(BC))付...*3は1個、*4は2個(両側)付

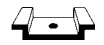

Reversing

S-2 x T32(BC)

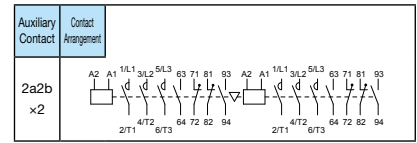
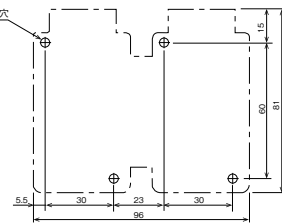
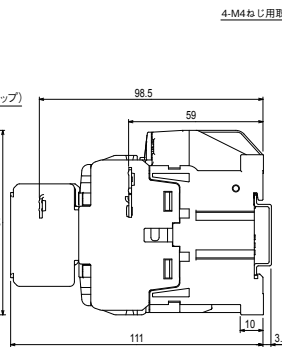
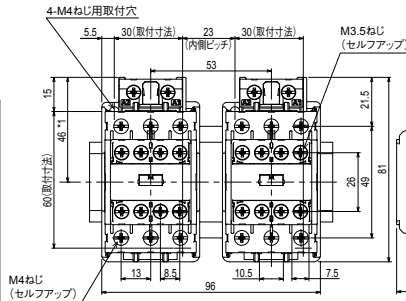

Model Name
S-2xT32
S-2xT32BC

*1 寸法:IEC35mm幅レールのセンタからの寸法

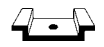

T65/T80 (The diagrams show models without "CW".)

Non-Reversing

MSO-T65(CW)KP
MSO-T80(CW)KP



1.1 kg

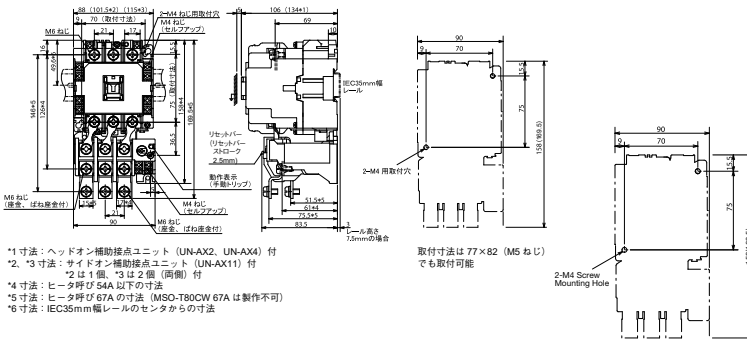

取付寸法は 77×82 (M5 ねじ) でも取付可能

Mounting Dimensions Also Allow For 77 x 82 (M5 Screw) Mounting

Contact Arrangement

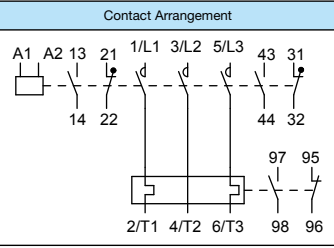

Model Name	
MSO-T65KP	MSO-T80KP



Reversing

MSO-2 x T65(CW)KP
MSO-2 x T80(CW)KP

2.2 kg

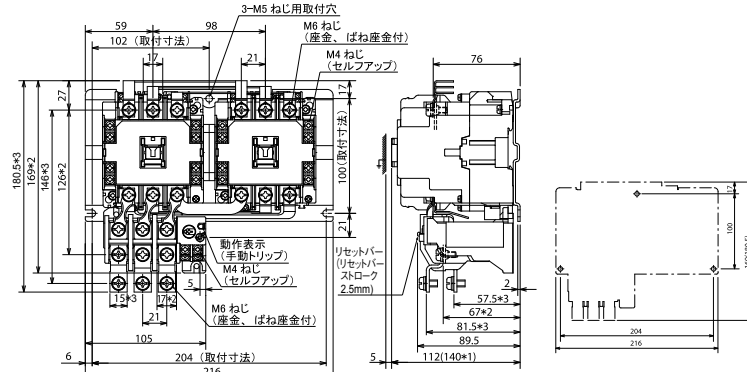

取付寸法は 77×82 (M5 ねじ) でも取付可能

Connection Diagram

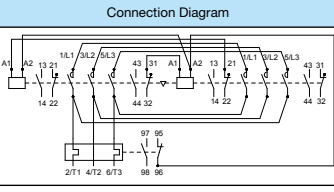

Model Name	
MSO-2xT65KP	MSO-2xT80KP



Non-Reversing

S-T65(CW)
S-T80(CW)



0.75 kg

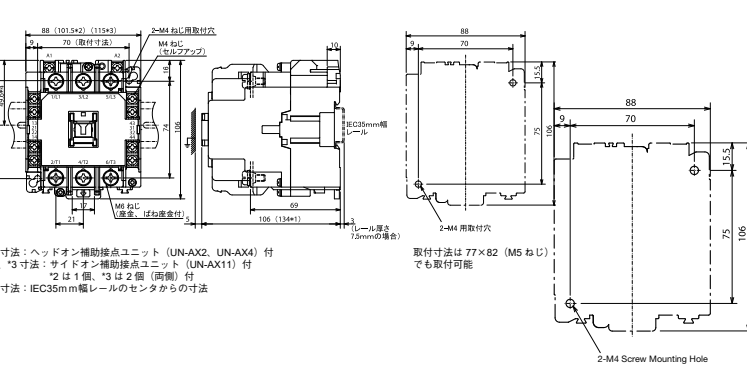

取付寸法は 77×82 (M5 ねじ) でも取付可能

Mounting Dimensions Also Allow For 77 x 82 (M5 Screw) Mounting

Contact Arrangement

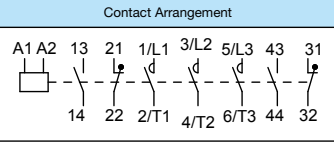

Model Name	
S-T65	S-T80



Reversing

S-2 x T65(CW)
S-2 x T80(CW)

1.9 kg

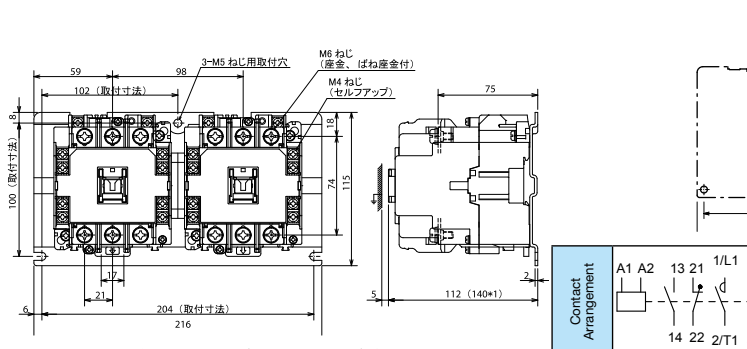

取付寸法は 77×82 (M5 ねじ) でも取付可能

Contact Arrangement

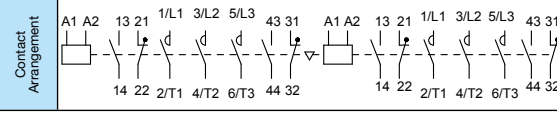

Model Name	
S-2xT65	S-2xT80



● Non-Reversing Magnetic Starter (Enclosed)

Enclosure (Case): Steel
Paint Color: Munsell 5Y7/1
Protective Structure: IP20

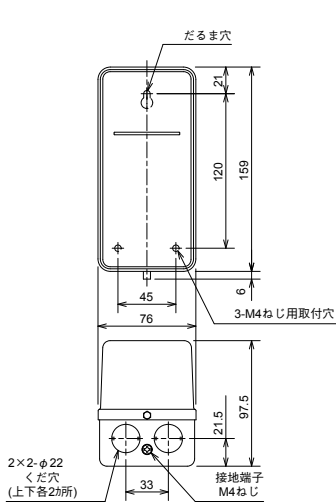

Fig 4. MS-T10KP (0.74 kg)
MS-T12KP (0.76 kg)

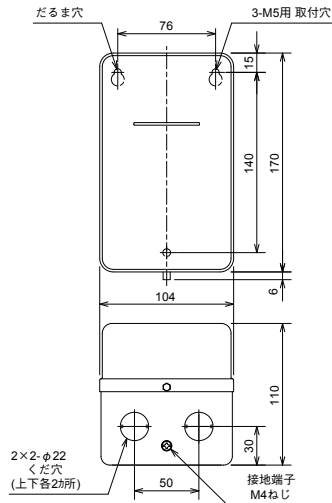

Fig 5. MS-T21KP (1.12 kg)

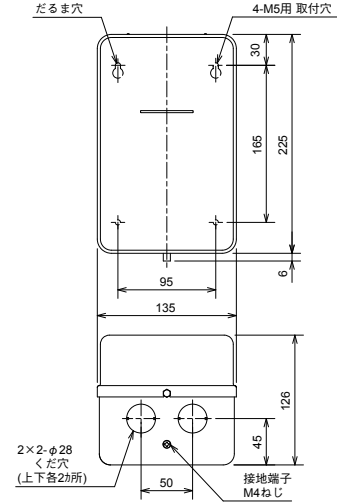

Fig 6. MS-T35KP/T50KP (1.9 kg)

Note 1. Leave 100 mm space at the bottom of the enclosure when mounting MS-T10KP to T50KP types.
Note 2. 3 rubber bushings are included for MS-T10KP to T50KP types.
Note 3. MS-T □ and MS-N □ types can also be manufactured.

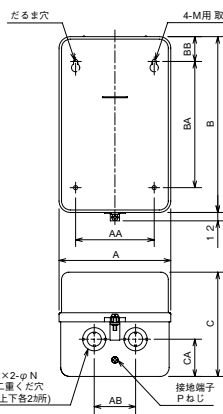

Fig 7. MS-T65KP to T100KP
MS-N125KP to N220KP

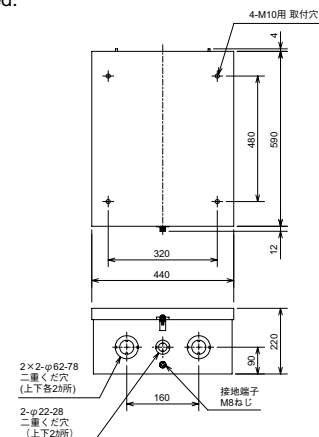
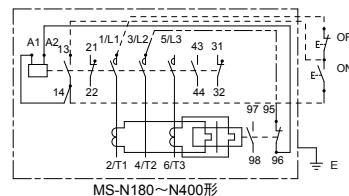
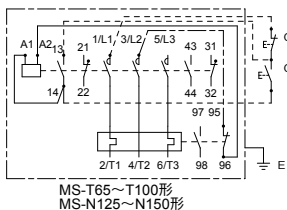
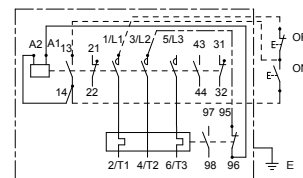
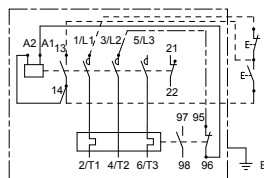
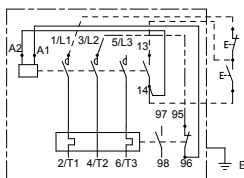

Fig 8. MS-N300KP/N400KP (27.5 kg/28 kg)

Model	Dimensions											Weight [kg]
	A	AA	AB	B	BA	BB	C	CA	M	N	P	
MS-T65KP/T80KP	160	120	80	270	220	25	145	45	M5	22 to 35	M4	2.9
MS-T100KP	190	150	100	305	260	25	163	67	M6	22 to 35	M4	4.0
MS-N125KP	230	170	90	384	330	29	190	80	M8	44 to 50	M6	8.0
MS-N150KP/N180KP/N220KP	270	200	120	484	400	44	209	85	M8	44 to 50	M6	12.8/16.2/16.2



Note 1) The figure above shows the same power supply for both the main circuit and control circuit.

The solid lines show completed wiring while the broken lines and double-dashed lines are still in need of wiring. (For the double-dashed lines, use the power supply attached to the unit)

Note 2) If the power supplies for the main circuit and control circuit differ, power wiring between the 1/L1-OFF button broken lines and the 3/L2-TH95 double-dashed lines is unnecessary, but the OFF button and TH95 terminal should be wired from the separate control circuit power supply.

Model Name	Model Name	Model Name	Model Name
MS-T10KP	MS-T65KP	MS-N125KP	MS-N400KP
MS-T12KP	MS-T80KP	MS-N150KP	
MS-T21KP	MS-T100KP	MS-N180KP	
MS-T35KP		MS-N220KP	
MS-T50KP		MS-N300KP	

● Reversing Magnetic Starters (Enclosed Type)

Enclosure (Case): Steel
 Paint Color: Munsell 5Y7/1
 Protective Structure: IP20

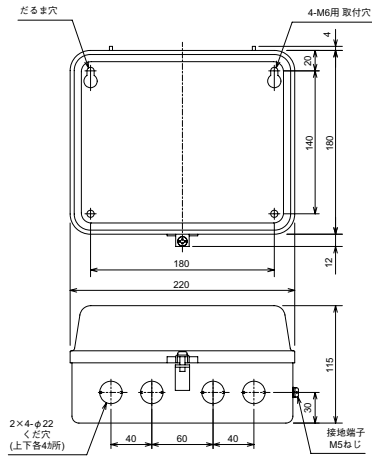

Fig. 9. MS-2xT21KP (2.0 kg)

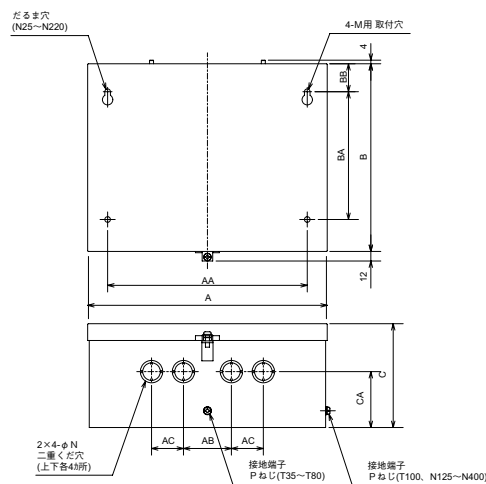
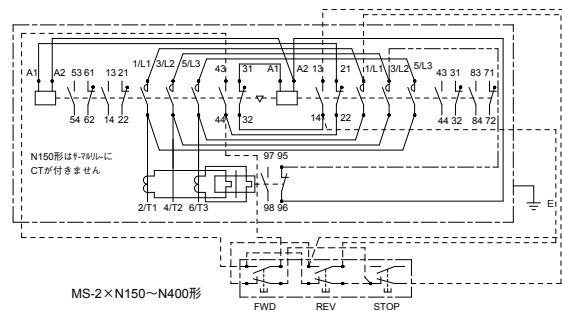
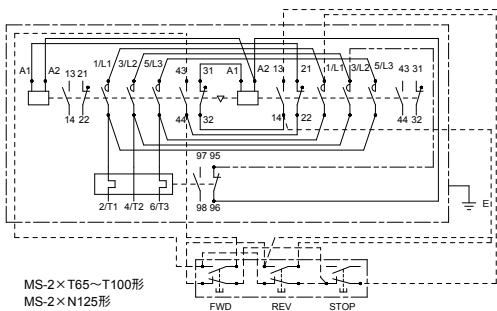
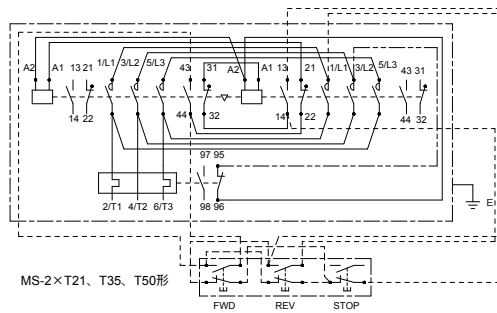

Fig. 10. MS-2xT35KP to T100KP, MS-2xN125KP to N400KP

Note 1. 3 rubber bushings are included for MS-2xT21 to T50.
 Note 2. MS-2xT □ and MS-2xN □ types can also be manufactured.

Model	Dimensions											Weight [kg]		
	A	AA	AB	AC	B	BA	BB	C	CA	M	N		O	P
MS-2xT35KP T50KP	300	250	60	40	235	160	35	130	70	M6	22 to 28	4	M5	4.7
MS-2xT65KP/T80KP	320	270	100	60	270	240	15	140	70	M6	22 to 35	4	M6	6.6
MS-2xT100KP	410	350	140	60	330	270	35	154	87	M6	22 to 35	4	M6	10
MS-2xN125KP	440	370	120	80	424	350	39	170	94	M8	44 to 50	4	M6	15.5
MS-2xN150KP/N180KP/N220KP	520	440	160	80	524	440	44	209	90	M8	44 to 50	4	M6	20.5/28.5/28.5
MS-2xN300KP/N400KP	600	500	130	120	604	500	54	230	100	M10	62 to 78	4	M8	46/47



Note 1) The figure above shows the same power supply for both the main circuit and control circuit.
 The solid lines show completed wiring while the broken lines and double-dashed lines are still in need of wiring. (For the double-dashed lines, use the power supply attached to the unit)
 Note 2) If the power supplies for the main circuit and control circuit differ, power wiring between the 1/L1-STOP button broken lines and the 3/L2-TH95 double-dashed lines is unnecessary, but the STOP button and TH95 terminal should be wired from the separate control circuit power supply.

Model Name	Model Name	Model Name	Model Name
MS-2xT21KP	MS-2xT80KP	MS-2xN125KP	MS-2xN300KP
MS-2xT35KP	MS-2xT100KP	MS-2xN150KP	MS-2xN400KP
MS-2xT50KP		MS-2xN180KP	
MS-2xT65KP		MS-2xN220KP	

● Outline Drawings/Contact Arrangements (AC Operated Magnetic Starters/Magnetic Contactors)

■ T10BC

Non-Reversing

MSO-T10BCKP

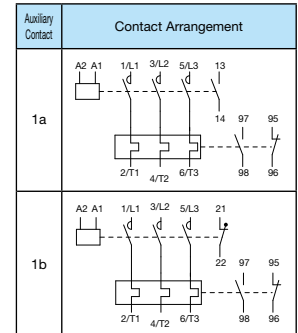
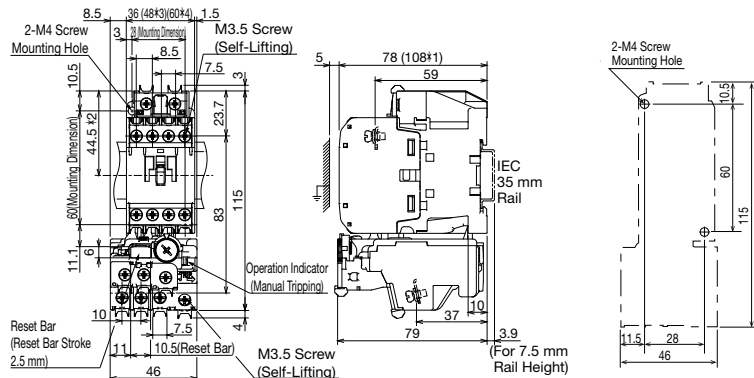

0.36kg

*1 Dimension: Including Head-On Auxiliary Contact Unit (UT-AX2(BC), UT-AX4(BC))
 *2 Dimension: Width Dimension from Center of IEC 35 mm Rail
 *3, *4 Dimension: Including Side-On Auxiliary Contact Unit (UT-AX11(BC)) - *3 Has 1 Piece, *4 Has 2 Pieces (Both Sides)
 It should be noted that it cannot be used with the head-on and side-on auxiliary contact units mounted at the same time.

Model Name
MSO-T10BCKP

Reversing

MSO-2 x T10BCKP

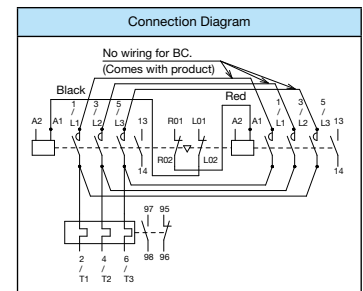
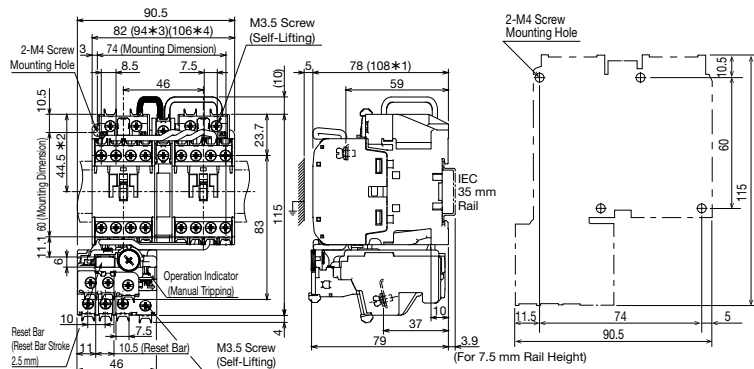

0.66kg

*1 Dimension: Including Head-On Auxiliary Contact Unit (UT-AX2(BC), UT-AX4(BC))
 *2 Dimension: Width Dimension from Center of IEC 35 mm Rail
 *3, *4 Dimension: Including Side-On Auxiliary Contact Unit (UT-AX11(BC)) - *3 Has 1 Piece, *4 Has 2 Pieces (Both Sides)
 It should be noted that it cannot be used with the head-on and side-on auxiliary contact units mounted at the same time.

Model Name
MSO-2xT10BCKP

Non-Reversing

S-T10BC

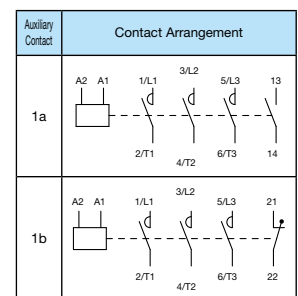
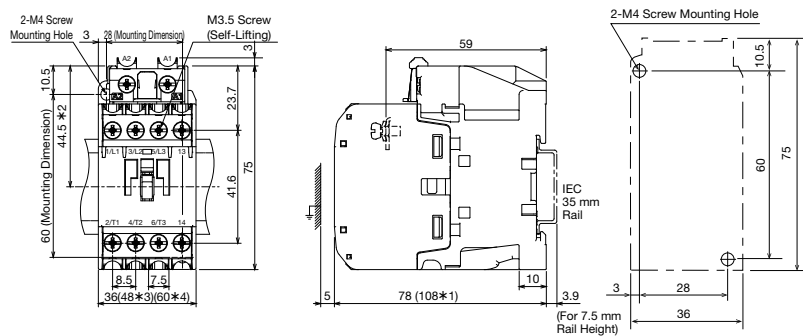

0.25kg

*1 Dimension: Including Head-On Auxiliary Contact Unit (UT-AX2(BC), UT-AX4(BC))
 *2 Dimension: Width Dimension from Center of IEC 35 mm Rail
 *3, *4 Dimension: Including Side-On Auxiliary Contact Unit (UT-AX11(BC)) - *3 Has 1 Piece, *4 Has 2 Pieces (Both Sides)
 It should be noted that it cannot be used with the head-on and side-on auxiliary contact units mounted at the same time.

Model Name
S-T10BC

Reversing

S-2 x T10BC

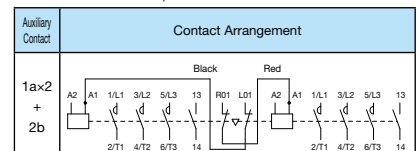
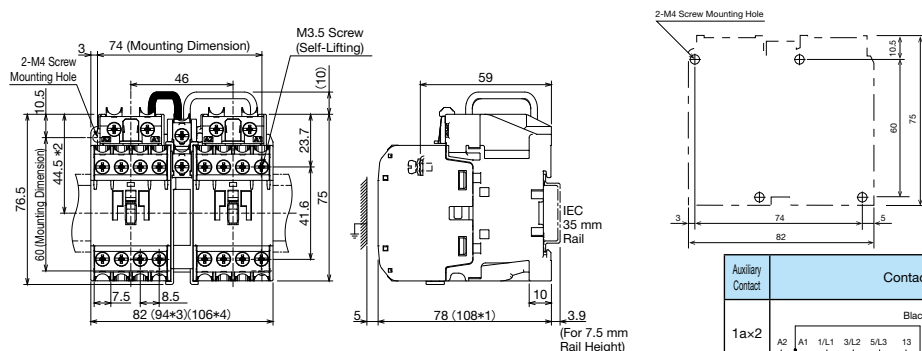

0.55kg

*1 Dimension: Including Head-On Auxiliary Contact Unit (UT-AX2(BC), UT-AX4(BC))
 *2 Dimension: Width Dimension from Center of IEC 35 mm Rail
 *3, *4 Dimension: Including Side-On Auxiliary Contact Unit (UT-AX11(BC)) - *3 Has 1 Piece, *4 Has 2 Pieces (Both Sides)
 It should be noted that it cannot be used with the head-on and side-on auxiliary contact units mounted at the same time.

Model Name
S-2xT10BC

T12/T20BC

Non-Reversing

MSO-T12BCKP
MSO-T20BCKP

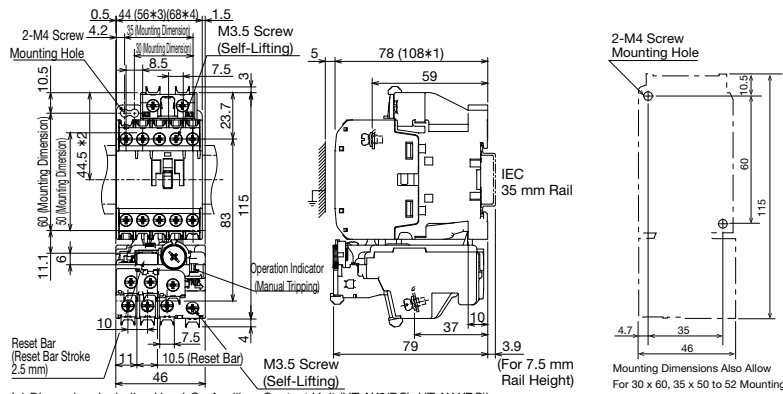

- *1 Dimension: Including Head-On Auxiliary Contact Unit (UT-AX2(BC), UT-AX4(BC))
 - *2 Dimension: Width Dimension from Center of IEC 35 mm Rail
 - *3, *4 Dimension: Including Side-On Auxiliary Contact Unit (UT-AX11(BC)) - *3 Has 1 Piece, *4 Has 2 Pieces (Both Sides)
- It should be noted that it cannot be used with the head-on and side-on auxiliary contact units mounted at the same time.

0.38kg

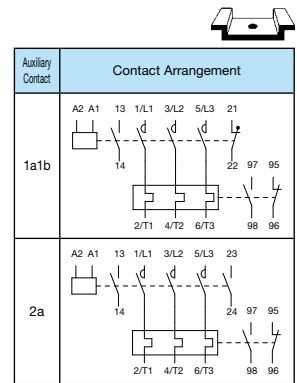

Model Name	
MSO-T12BCKP	
MSO-T20BCKP	

Reversing

MSO-2xT12BCKP
MSO-2xT20BCKP

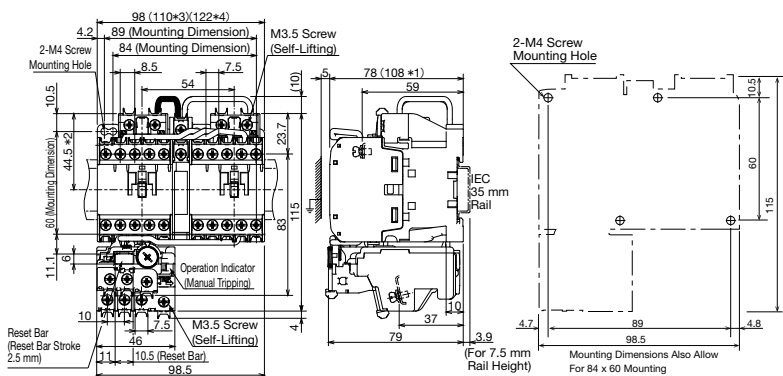

- *1 Dimension: Including Head-On Auxiliary Contact Unit (UT-AX2(BC), UT-AX4(BC))
 - *2 Dimension: Width Dimension from Center of IEC 35 mm Rail
 - *3, *4 Dimension: Including Side-On Auxiliary Contact Unit (UT-AX11(BC))
- It should be noted that it cannot be used with the head-on and side-on auxiliary contact units mounted at the same time.

0.7kg

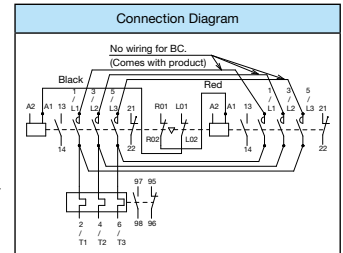

Model Name	
MSO-2xT12BCKP	
MSO-2xT20BCKP	

Non-Reversing

S-T12BC
S-T20BC

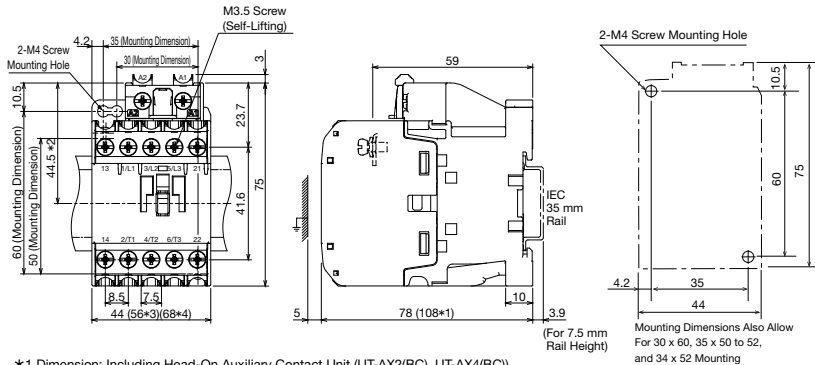

- *1 Dimension: Including Head-On Auxiliary Contact Unit (UT-AX2(BC), UT-AX4(BC))
 - *2 Dimension: Width Dimension from Center of IEC 35 mm Rail
 - *3, *4 Dimension: Including Side-On Auxiliary Contact Unit (UT-AX11(BC)) - *3 Has 1 Piece, *4 Has 2 Pieces (Both Sides)
- It should be noted that it cannot be used with the head-on and side-on auxiliary contact units mounted at the same time.

0.27kg

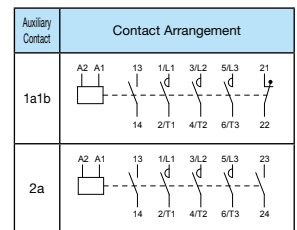

Model Name	
S-T12BC	
S-T20BC	

Reversing

S-2xT12BC
S-2xT20BC

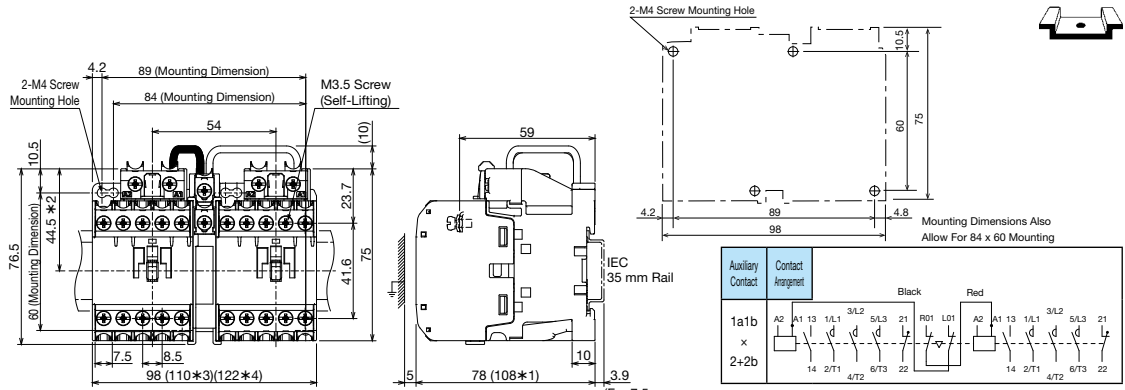

- *1 Dimension: Including Head-On Auxiliary Contact Unit (UT-AX2(BC), UT-AX4(BC))
 - *2 Dimension: Width Dimension from Center of IEC 35 mm Rail
 - *3, *4 Dimension: Including Side-On Auxiliary Contact Unit (UT-AX11(BC)) - *3 Has 1 Piece, *4 Has 2 Pieces (Both Sides)
- It should be noted that it cannot be used with the head-on and side-on auxiliary contact units mounted at the same time.

0.59kg

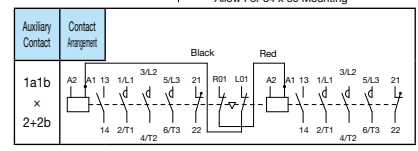

Model Name	
S-2xT12BC	
S-2xT20BC	

T21/T25BC

Non-Reversing

MSO-T21BCKP
MSO-T25BCKP

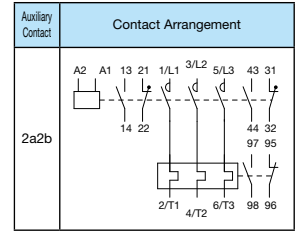
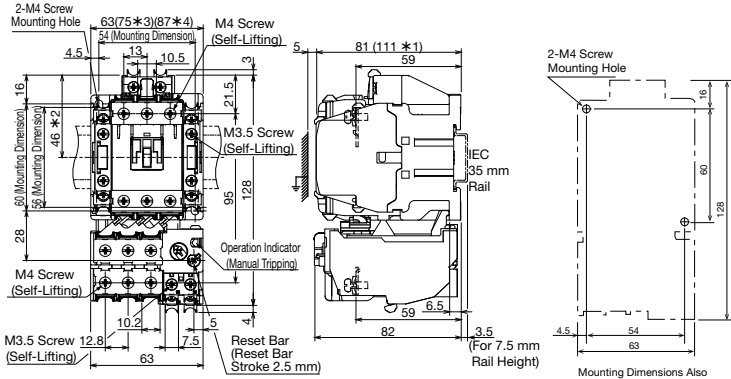

0.58 kg

- *1 Dimension: Including Head-On Auxiliary Contact Unit (UT-AX2(BC), UT-AX4(BC))
 - *2 Dimension: Width Dimension from Center of IEC 35 mm Rail
 - *3, *4 Dimension: Including Side-On Auxiliary Contact Unit (UT-AX11(BC)) - *3 Has 1 Piece, *4 Has 2 Pieces (Both Sides)
- It should be noted that it cannot be used with the head-on and side-on auxiliary contact units mounted at the same time.

Model Name
MSO-T21BCKP
MSO-T25BCKP

Reversing

MSO-2 x T21BCKP
MSO-2 x T25BCKP

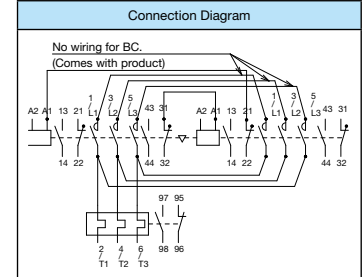
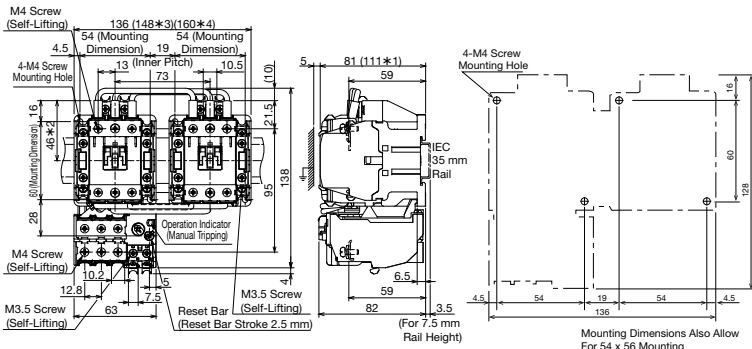

1.03 kg

- *1 Dimension: Including Head-On Auxiliary Contact Unit (UT-AX2(BC), UT-AX4(BC))
 - *2 Dimension: Width Dimension from Center of IEC 35 mm Rail
 - *3, *4 Dimension: Including Side-On Auxiliary Contact Unit (UT-AX11(BC)) - *3 Has 1 Piece, *4 Has 2 Pieces (Both Sides)
- It should be noted that it cannot be used with the head-on and side-on auxiliary contact units mounted at the same time.

Model Name
MSO-2xT21BCKP
MSO-2xT25BCKP

Non-Reversing

S-T21BC
S-T25BC

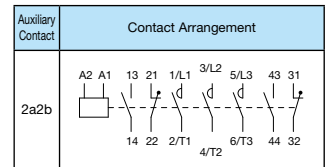
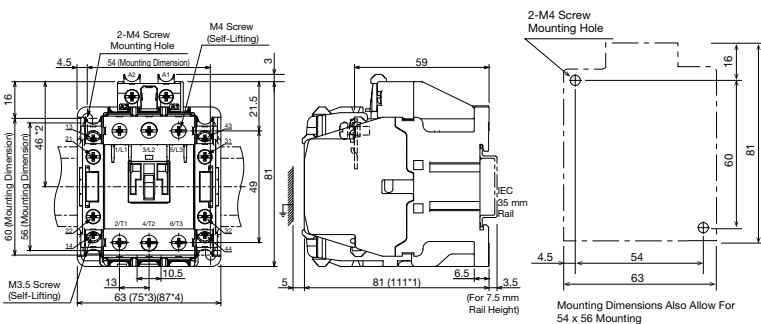

0.41 kg

- *1 Dimension: Including Head-On Auxiliary Contact Unit (UT-AX2(BC), UT-AX4(BC))
 - *2 Dimension: Width Dimension from Center of IEC 35 mm Rail
 - *3, *4 Dimension: Including Side-On Auxiliary Contact Unit (UT-AX11(BC)) - *3 Has 1 Piece, *4 Has 2 Pieces (Both Sides)
- It should be noted that it cannot be used with the head-on and side-on auxiliary contact units mounted at the same time.

Model Name
S-T21BC
S-T25BC

Reversing

S-2 x T21BC
S-2 x T25BC

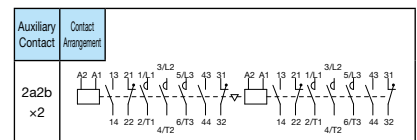
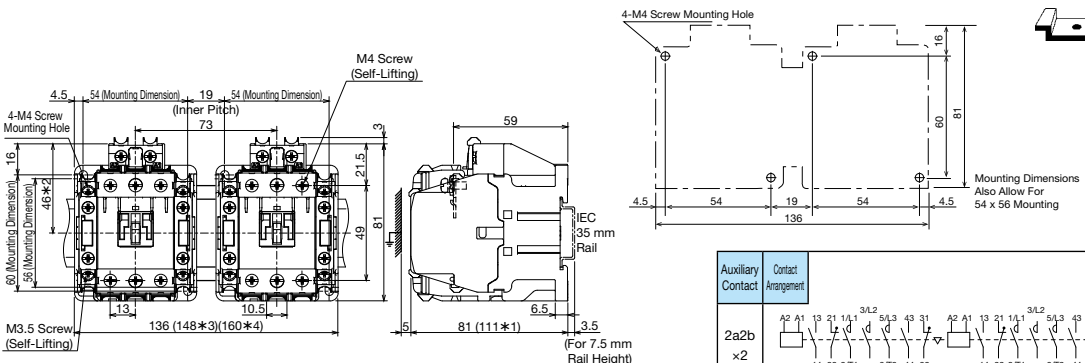

0.86 kg

- *1 Dimension: Including Head-On Auxiliary Contact Unit (UT-AX2(BC), UT-AX4(BC))
 - *2 Dimension: Width Dimension from Center of IEC 35 mm Rail
 - *3, *4 Dimension: Including Side-On Auxiliary Contact Unit (UT-AX11(BC)) - *3 Has 1 Piece, *4 Has 2 Pieces (Both Sides)
- It should be noted that it cannot be used with the head-on and side-on auxiliary contact units mounted at the same time.

Model Name
S-2xT21BC
S-2xT25BC

T32BC

Non-Reversing

S-T32BC

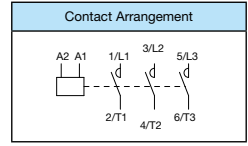
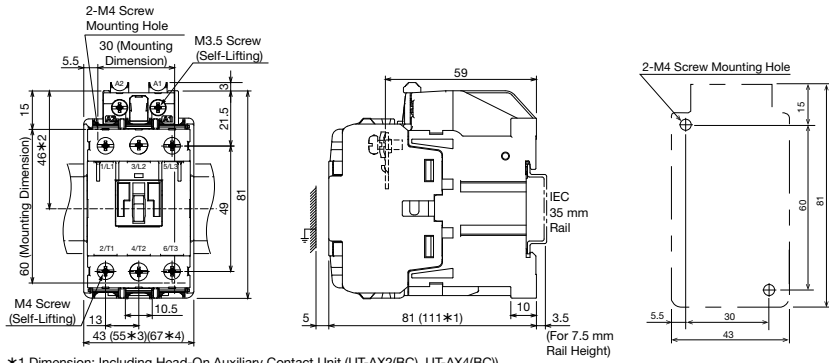

Model Name
S-T32BC

0.36 kg

- *1 Dimension: Including Head-On Auxiliary Contact Unit (UT-AX2(BC), UT-AX4(BC))
 - *2 Dimension: Width Dimension from Center of IEC 35 mm Rail
 - *3, *4 Dimension: Including Side-On Auxiliary Contact Unit (UT-AX11(BC)) - *3 Has 1 Piece, *4 Has 2 Pieces (Both Sides)
- It should be noted that it cannot be used with the head-on and side-on auxiliary contact units mounted at the same time.

4

Reversing

S-2 x T32BC

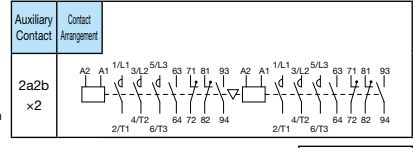
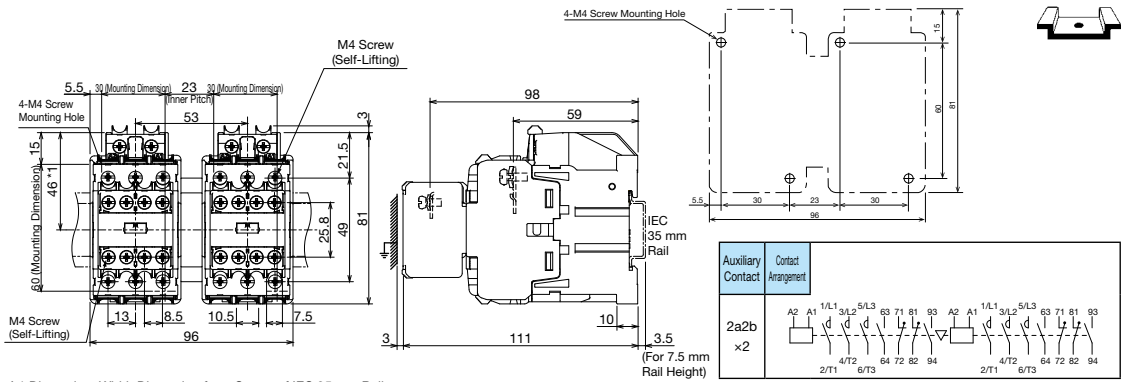

Model Name
S-2xT32BC

0.84 kg

- *1 Dimension: Width Dimension from Center of IEC 35 mm Rail

T35/T50BC

Non-Reversing

MSO-T35BCKP
MSO-T50BCKP

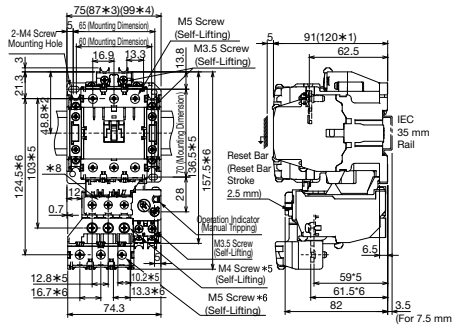

- *1 Dimension: Including Head-On Auxiliary Contact Unit (UT-AX2(BC), UT-AX4(BC))
 - *2 Dimension: Width Dimension from Center of IEC 35 mm Rail
 - *3, *4 Dimension: Including Side-On Auxiliary Contact Unit (UT-AX11(BC))
 - *5 Dimension: Heater Designations 22A or Less, *6 Dimension: Heater Designations 29A or More
- Note 1. Products with a heater designation of 29A do not have fast wiring terminals on the power side terminal cover of the thermal overload relay.

0.79 kg

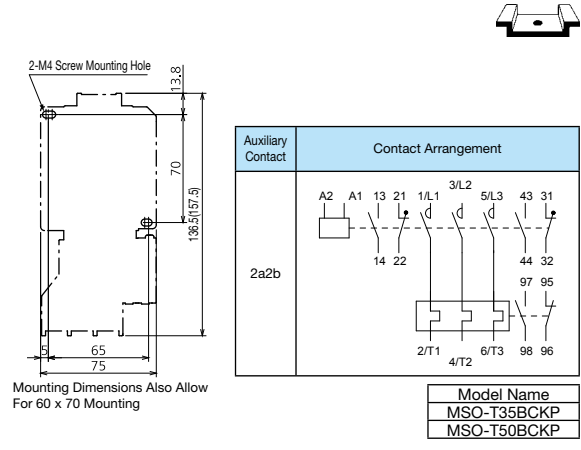

Reversing

MSO-2 x T35BCKP
MSO-2 x T50BCKP

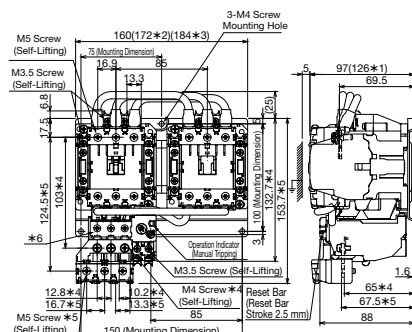

- *1 Dimension: Including Head-On Auxiliary Contact Unit (UT-AX2(BC), UT-AX4(BC))
 - *2, *3 Dimension: Including Side-On Auxiliary Contact Unit (UT-AX11(BC))
 - *2 Has 1 Piece, *3 Has 2 Pieces (Both Sides)
 - *4 Dimension: Heater Designations 22A or Less, *5 Dimension: Heater Designations 29A or More
- Note 1. Products with a heater designation of 29A do not have fast wiring terminals on the power side terminal cover of the thermal overload relay.

1.54 kg

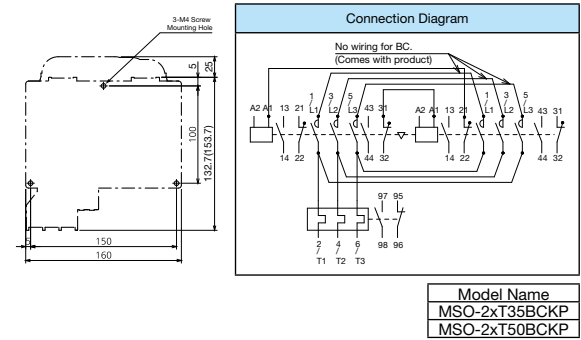

Non-Reversing

S-T35BC
S-T50BC

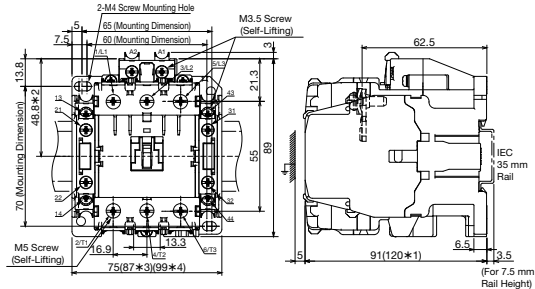

- *1 Dimension: Including Head-On Auxiliary Contact Unit (UT-AX2(BC), UT-AX4(BC))
 - *2 Dimension: Width Dimension from Center of IEC 35 mm Rail
 - *3, *4 Dimension: Including Side-On Auxiliary Contact Unit (UT-AX11(BC))
 - *3 Has 1 Piece, *4 Has 2 Pieces (Both Sides)
- It should be noted that it cannot be used with the head-on and side-on auxiliary contact units mounted at the same time.

0.55 kg

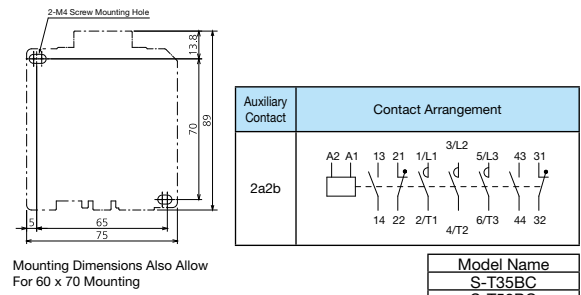

Reversing

S-2 x T35BC
S-2 x T50BC

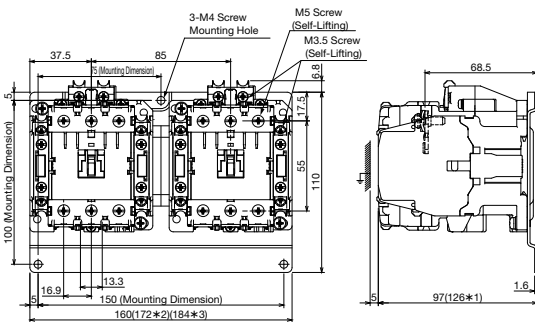

- *1 Dimension: Including Head-On Auxiliary Contact Unit (UT-AX2(BC), UT-AX4(BC))
 - *2, *3 Dimension: Including Side-On Auxiliary Contact Unit (UT-AX11(BC))
 - *2 Has 1 Piece, *3 Has 2 Pieces (Both Sides)
- It should be noted that it cannot be used with the head-on and side-on auxiliary contact units mounted at the same time.

1.3 kg

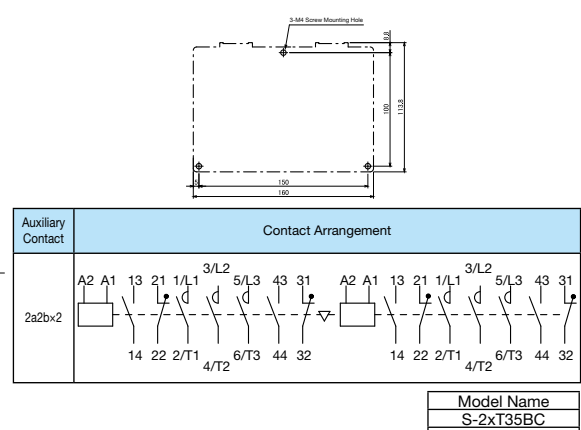

4.10 S-T□SQ, SD-T□SQ Magnetic Contactors with Spring Clamp Terminals

Just insert solid wires or ferrules into terminals. No terminal screws are required, which makes wiring quicker and easier.

● **Shorter Wiring Time**

Wiring time becomes shorter than the time required for tightening screws.

No worry about loss of screws.

Solid wires, stranded wires, and ferrules can be connected to the terminals.

● **Easier Maintenance**

No worry about loose screws. Conventionally, terminal screws come loose due to vibrations, impacts, or long-time use, and must be tightened when products come in or during inspection.

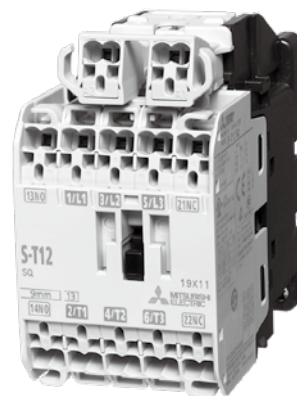

S-T12SQ

● **Manufacturing Range List**

Model	Non-Reversing		Terminal
	Magnetic Contactors		
Frame	Model Name	Auxiliary Contact	
T12	S-T12SQ	1a1b, 2a, 2b	Spring Clamp Terminals
	SD-T12SQ	1a1b, 2a	
T20	S-T20SQ	1a1b, 2a, 2b	
	SD-T20SQ	1a1b, 2a	

Note 1. Terminal numbers are compliant with EN standards (EN50005 and EN50012).

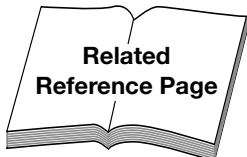
	Item	Reference Page	Remarks
	• Main Contact Rating	Page 39	—
	• Auxiliary Contact Rating	Page 41	—
	• Operation Coil	Page 43	—
	• Properties	Page 45	—
	• Performance	Page 46	—
	• Applicable wires	Page 68	—
	• How to Order	Page 131	—
	• Combining with Optional Units	Page 194	Devices such as coil surge absorbers and manual operation prevention covers can be installed.

4.11 S(D)-T32, S-N□8 Main Circuit 3-Pole Magnetic Contactors

Dramatically reduces panel installation area required

- A space-saving type without auxiliary contacts equipped and just 3-pole main contacts.
- If auxiliary contacts are required, auxiliary contact units can be installed. (Reversing types have 2a2b x 2 installed)



S-T32

S-N48

● Ratings/Specifications (Standard Applicability)

Magnetic Contactors		Rated Capacity [kW]				Rated Operating Current [A]				Conventional Free Air Thermal Current [A]	Additional Auxiliary Contact Unit Model Name x Pieces (Note 2)	Terminal Screw Size (Standard Tightening Torque N·m)		Recommended Crimp Lug Size Compatible with Terminal			
		Three-Phase Squirrel-cage Motor (Category AC-3)				Three-Phase Squirrel-cage Motor (Category AC-3)						Resistive Load (Category AC-1)		Main Circuit	Control Circuit	Main Circuit	Control Circuit
Non-Reversing	Reversing	220 to 240 V	380 to 440 V	500 V	690 V	220 to 240 V	380 to 440 V	500 V	690 V	200 to 220 V	380 to 440 V	I _{th} [A]					
S-T32(BC)	S-2 x T32(BC)	7.5	15	15	11	32	32	24	12	32	32	32	UT-AX2, 4 x 1 UT-AX11 x 2	M4 1.18 - 1.86 (1.47)	M3.5 0.94 - 1.51 (1.17)	1.25-4 to 5.5-4	1.25-3.5 to 2-3.5
SD-T32(BC)	SD-2 x T32(BC)																
S-N38(CX)	S-2 x N38(CX)	7.5	15	15		35	32	24		60	60	60	UN-AX2, 4 x 1 (Front Clip-on)	M5 2.06 - 3.33 (2.55)	M3.5 0.94 - 1.51 (1.17)	1.25-5 to 14-5	1.25-3.5 to 2-3.5
S-N48(CX)	S-2 x N48(CX)	11	15	15		50	35	24		80	80	80					

Note 1. The M4 main circuit terminal screw size for T32 types makes it unsuitable for applications exceeding 20 A in accordance with the Electrical Appliance and Material Safety Law.

Note 2. Reversing types already have 2 UT/UN-AX4 units installed so no more can be mounted. Furthermore, all side clip-on units (UT/UN-AX11) are not applicable.

Note 3. Types including thermal overload relays (MSO) are not manufactured.

Note 4. A "BC" in the model name indicates a wiring streamlining terminal, "CX" indicates a CAN terminal.

Note 5. Please note that SD-T32 type operation coil terminals have polarity. A1 (+), A2 (-)

● Properties/Performance

Model Name	Input [VA]		Power Consumption [W]	Coil Current [mA]	Operating Voltage [V]		Operating Time [ms]		Making Current Capacity [A] (Peak 0.5 ms)	Switching Frequency	Switching Durability [x 10000]	
	Momentary	Regular			Close	Open	Coil ON→ Main Contact ON	Coil OFF→ Main Contact OFF			Mechanical	Electrical (Category AC-3)
SD-T32	—	—	3.3 (2.2)	0.033	60 to 75	10 to 30	70 (95)	20	400	1800 Times/Hour	1000	200
S-T32	55	4.5	1.8	20	125 to 155	80 to 115	15 to 22	5 to 15	400			
S-N38	110	13	4.3	80	120 to 145	90 to 115	10 to 20	5 to 14	500	1200 Times/Hour	500	100
S-N48	110	13	4.3	80	120 to 145	90 to 115	10 to 20	5 to 14	670			

Note 1. The above table indicates rough property indices for DC100V coils for DC operated types and AC200V coils for AC operated types. The values in the parentheses for SD-T32 indicate rough property indices for DC12V or DC24V coils.

Note 2. The operating voltage is that at a 20°C cold state. (AC operated type values are for 60 Hz)

Note 3. The coil current is the average regular value with DC100V (DC operated type) or AC220 V at 60 Hz (AC operated type) applied.

Note 4. The operating time is the value with DC100V (DC operated type) or AC220 V at 60 Hz (AC operated type) applied.

Note 5. The coil input and power consumption are the average values.

Note 6. The electrical durability at the making current capacity lasts 100,000 operations.

	Item	Reference Page	Remarks
	· Main Contact Rating	Page 39	—
	· Operation Coil	Page 43	—
	· How to Order	Pages 131,133	—
	· Combining with Optional Units	Page 194	—

4.12 How to Order

Precautions

Follow the steps below when ordering. Enter a space in ▲.
 If there are multiple 2 letter symbols (SA, BC, KP etc.) appended to the model name frame size (T10 etc.) then specify them in alphabetical order. (E.g.: MSO-T10BCKPSA)
 (If not in alphabetical order, the model name displayed will change automatically.)

● MS-T Series

1. Standard (AC Operated) Magnetic Starters

■ MS-(2x)T (Enclosed Type)

Model Name	Motor Capacity	Main Circuit Voltage	Operation Coil Designation or Control Circuit Voltage/Frequency	(Note) Auxiliary Contact
MS-T21KP MS-T10KP	▲ 3.7kW	▲ 200V 200V	▲ AC200V AC200V	▲ 1B
Refer to pages 74 and 75.	Select from page 48 or 139.	Do not apply AC voltage to the main circuit. (To distinguish it from the control circuit voltage)	Select the coil designation from page 43 or specify the control circuit voltage and frequency used.	Specify if using a special contact arrangement. Refer to page 41.

■ MSO-(2x)T (Open Type)

Model Name	Motor Capacity or Heater Designation (Knob Setpoint)	Main Circuit Voltage	Operation Coil Designation or Control Circuit Voltage/Frequency	(Note) Auxiliary Contact
MSO-T10KP	▲ 9A	▲ 200V	▲ AC200V	▲ 1B
Refer to pages 74 and 75.	Select from page 48 or 139.	Do not apply AC voltage to the main circuit. (To distinguish it from the control circuit voltage)	Select the coil designation from page 43 or specify the control circuit voltage and frequency used.	Specify if using a special contact arrangement. Refer to page 41.

2. Standard (AC Operated) Magnetic Contactors

■ S-T Type, S-2xT Type

Model Name	Operation Coil Designation or Control Circuit Voltage and Frequency	(Note) Auxiliary Contact
S-T20 S-T20	▲ AC200V AC100V50Hz	▲ 2A
Refer to pages 74 and 75.	Select the coil designation from page 43 or specify the control circuit voltage and frequency used.	Specify if using a special contact arrangement. Refer to page 41.

3. DC Operated Magnetic Starters/Contactors

■ MSOD-T Type

Model Name	Motor Capacity or Heater Designation (Knob Setpoint)	Main Circuit Voltage	Operation Coil Designation	(Note) Auxiliary Contact
MSOD-T21KP	▲ 3.7kW	▲ 200V	▲ DC100V	▲
Refer to page 91.	Select from page 48 or 139.	Do not apply AC voltage to the main circuit.	Select the coil designation from page 44.	Specify if using a special contact arrangement. Refer to page 41.

■ SD-T Type

Model Name	Operation Coil Designation	(Note) Auxiliary Contact
SD-T21	▲ DC110V	▲
Refer to page 91. SD-2 x T21 is a reversing type.	Select the coil designation from page 44.	Specify if using a special contact arrangement. Refer to page 41.

4. Mechanically Latched Magnetic Starters/Contactors

■ MSOL-T Type

Model Name	Motor Capacity or Heater Designation (Knob Setpoint)	Main Circuit Voltage	Closing Coil	Tripping Coil
MSOL-T21KP	▲ 3.7kW	▲ 200V	▲ MC-AC200V	▲ MT-AC200V
Specify "MSOLD" if using a DC operated closing coil. Refer to page 102.	Select from page 48 or 139.	Do not apply AC voltage to the main circuit. (To distinguish it from the control circuit voltage)	Select the coil designation from page 44.	

■ SL-T Type, SLD-T Type

Model Name	Closing Coil Designation	Tripping Coil Designation
SL-T21	▲ MC-AC100V	▲ MT-AC100V
Refer to page 102. · The model name is SLD if using a DC operated closing coil.	Select the coil designation from page 44.	

■ SL-2xT Type, SLD-2xT Type

Specify using the SL-T type listed above if the left and right closing coils or tripping coils have the same ratings. However, specify using the following if the left and right coils have different ratings.

Model Name	Closing Coil Designation (Left Side)	Tripping Coil Designation (Left Side)	Closing Coil Designation (Right Side)	Tripping Coil Designation (Right Side)
SL-2xT21	▲ MC1-AC100V	▲ MT1-AC100V	▲ MC2-AC100V	▲ MT2-DC100V
Refer to page 102. · The model name is SLD if using a DC operated closing coil.	Select the coil designation from page 44.			

5. Delay Open Magnetic Starters/Contactors

■ MSO-T□DL, S-T□DL Type

Model Name	Main Circuit Specifications	Operation Coil
MSO-T21DLKP S-T12DL	▲ 15A 200V	▲ 200V ▲ AC200V AC200V
Specify from page 111.	Specify the rated voltages of the thermal overload relay heater designation and main circuit. Be sure to specify the rated voltage as there are strict criteria for the internal wiring of magnetic contactors.	The operation coil designation is available in AC100V and AC200V.

6. Magnetic Starters with Delay Trip Thermal Overload Relays

■ MSO-T □ SR Type

Model Name	Motor Capacity or Heater Designation (Knob Setpoint)	Main Circuit Voltage	Operation Coil Designation or Control Circuit Voltage/Frequency	(Note) Auxiliary Contact
MSO-T12SR	2.2kW	200V	AC200V	
Specify from page 114.	Select from page 48 or 139.	Do not apply AC voltage to the main circuit.	Select the coil designation from page 43 or specify the control circuit voltage and frequency used.	Specify if using a special contact arrangement. Refer to page 41.

7. Magnetic Starters with Quick Trip Thermal Overload Relays

■ MSO-T □ FS/FSKP Type

Model Name	Motor Capacity or Heater Designation (Knob Setpoint)	Main Circuit Voltage	Operation Coil Designation or Control Circuit Voltage/Frequency	(Note) Auxiliary Contact
MSO-T12FSKP	2.2kW	200V	AC200V	
Specify from page 116.	Select from page 48 or 139.	Do not apply AC voltage to the main circuit.	Select the coil designation from page 43 or specify the control circuit voltage and frequency used.	Specify if using a special contact arrangement. Refer to page 41.

8. Magnetic Starters with Push-Buttons

■ MS-T □ KPPM Type

Model Name	Motor Capacity	Main Circuit Voltage	Operation Coil Designation or Control Circuit Voltage/Frequency	(Note) Auxiliary Contact
MS-T21KPPM	3.7kW	200V	AC200V	
Specify from page 117.	Select from page 48 or 139.	Do not apply AC voltage to the main circuit. (To distinguish it from the control circuit voltage)	Select the coil designation from page 43 or specify the control circuit voltage and frequency used.	Specify if using a special contact arrangement. Refer to page 41.

9. Magnetic Starters/Magnetic Contactors with Wiring Streamlining Terminals

■ MSO-T □ BC Type

Model Name	Motor Capacity or Heater Designation (Knob Setpoint)	Main Circuit Voltage	Operation Coil Designation or Control Circuit Voltage/Frequency	(Note) Auxiliary Contact
MSO-T12BCKP	2.2kW	200V	AC200V	
Specify from page 119.	Select from page 48 or 139.	Do not apply AC voltage to the main circuit.	Select the coil designation from page 43 or specify the control circuit voltage and frequency used.	Specify if using a special contact arrangement. Refer to page 41.

■ S-T □ BC Type

Model Name	Operation Coil Designation or Control Circuit Voltage and Frequency	(Note) Auxiliary Contact
S-T12BC	AC200V	
Specify from page 119.	Select the coil designation from page 43 or specify the control circuit voltage and frequency used.	Specify if using a special contact arrangement. Refer to page 41.

10. Magnetic Contactors with Spring Clamp Terminals

■ S-T □ SQ Type

Model Name	Operation Coil Designation or Control Circuit Voltage and Frequency
S-T12SQ	AC200V
Specify from page 125.	Select the coil designation from page 43 or specify the control circuit voltage and frequency used.

■ SD-T □ SQ Type

Model Name	Operation Coil Designation or Control Circuit Voltage and Frequency
SD-T12SQ	DC100V
Specify from page 125.	Select the coil designation from page 44 or specify the control circuit voltage and frequency used.

11. Main Circuit 3-Pole Magnetic Contactors

■ S-T Type, S-2xT Type

Model Name	Operation Coil Designation or Control Circuit Voltage and Frequency
S-T32	AC200V
Specify from page 127.	Select the coil designation from page 43 or specify the control circuit voltage and frequency used.

■ SD-T Type, SD-2xT Type

Model Name	Operation Coil Designation or Control Circuit Voltage and Frequency
SD-T32	DC100V
Specify from page 127.	Select the coil designation from page 44 or specify the control circuit voltage and frequency used.