

2.1 Model List

| Frame | | | T10 | T12 | T20 | T21 | T25 | T32 | T35 | T50 | | |
|--|--|-----------------------------|---|-----------------|-----------------|----------------|-----------------|----------------|-----------------|-----------------|-----------------------|---------|
| Applicable standard | | | JIS C8201-4-1, IEC60947-4-1, EN60947-4-1, GB14048.4 | | | | | | | | | |
| Model Name | Magnetic Contactors (Without Thermal Overload Relay, Open Type) | Non-Reversing | S-T10 | S-T12 | S-T20 | S-T21 | S-T25 | S-T32 | S-T35 | S-T50 | | |
| | | Reversing | S-2 x T10 | S-2 x T12 | S-2 x T20 | S-2 x T21 | S-2 x T25 | S-2 x T32 | S-2 x T35 | S-2 x T50 | | |
| | Magnetic Starters (With standard 2-element, With Thermal Overload Relay) | Enclosed Type | Non-Reversing | MS-T10 | MS-T12 | — | MS-T21 | — | — | MS-T35 | MS-T50 | |
| | | | Reversing | — | — | — | MS-2 x T21 | — | — | MS-2 x T35 | MS-2 x T50 | |
| | | Open Type | Non-Reversing | MSO-T10 | MSO-T12 | MSO-T20 | MSO-T21 | MSO-T25 | — | MSO-T35 | MSO-T50 | |
| | | | Reversing | MSO-2 x T10 | MSO-2 x T12 | MSO-2 x T20 | MSO-2 x T21 | MSO-2 x T25 | — | MSO-2 x T35 | MSO-2 x T50 | |
| | Combined Thermal Overload Relays | | | TH-T18 | | | TH-T25 | | | TH-T25 / T50 | TH-T25 / T50 | |
| | Magnetic Starters With 3-element type Thermal Overload Relays | Enclosed Type | Non-Reversing | MS-T10KP | MS-T12KP | — | MS-T21KP | — | — | MS-T35KP | MS-T50KP | |
| | | | Reversing | — | — | — | MS-2 x T21KP | — | — | MS-2 x T35KP | MS-2 x T50KP | |
| | | Open Type | Non-Reversing | MSO-T10KP | MSO-T12KP | MSO-T20KP | MSO-T21KP | MSO-T25KP | — | MSO-T35KP | MSO-T50KP | |
| Reversing | | | MSO-2 x T10KP | MSO-2 x T12KP | MSO-2 x T20KP | MSO-2 x T21KP | MSO-2 x T25KP | — | MSO-2 x T35KP | MSO-2 x T50KP | | |
| Combined Thermal Overload Relays | | | TH-T18KP | | | TH-T25KP | | | TH-T25 / T50KP | TH-T25 / T50KP | | |
| Main contact rating | Rated Insulation Voltage [V] | | 690 | | | | | | | | | |
| | Rated Impulse Withstand Voltage [kV] | | 6 | | | | | | | | | |
| | Rated Frequency [Hz] | | 50/60 | | | | | | | | | |
| | Pollution Degree | | 3 | | | | | | | | | |
| | Rated operational current / power Category AC-3 (Note 1) (Three-phase squirrel-cage motor load standard responsibility) (Note 2) [kW/A] | AC220 to 240V | 2.5/11 [2.2/11] | 3.5/13 [2.7/13] | 4.5/18 [3.7/18] | 5.5/25 [4/20] | 7.5/30 [26] | 5.5/28 | 7.5/32 [7.5/32] | 11/40 [7.5/35] | 15/55 [50] | [11/50] |
| | | AC380 to 440V | 4/9 [2.7/7] | 5.5/12 [4/9] | 7.5/18 [7.5/18] | 11/23 [7.5/20] | 15/30 [26] | [11/25] | 15/32 [15/32] | 18.5/40 [15/32] | 22/50 [22/48] | |
| | | AC500V | 4/7 [2.7/6] | 5.5/9 [5.5/9] | 7.5/17 [7.5/17] | 11/17 [7.5/17] | 15/24 [11/20] | 15/24 [11/20] | 15/24 [11/20] | 18.5/32 [15/26] | 25/38 [22/38] | |
| | | AC690V | 4/5 | 5.5/7 | 7.5/9 | 7.5/9 | 11/12 | 11/12 | 11/12 | 15/17 | 22/26 | |
| | Rated operational current / power Category AC-4 (Three-phase squirrel-cage motor load inching responsibility) [kW/A] | AC220 to 240V | 1.5/8 | 2.2/11 | 3.7/18 | 4.5/20 | 5.5/26 | 5.5/26 | 5.5/26 | 7.5/35 | | |
| | | AC380 to 440V | 2.2/6 | 4/9 | 5.5/13 | 7.5/17 | 11/24 | 11/24 | 11/24 | 15/32 | | |
| AC500V | | 2.7/6 | 5.5/9 | 5.5/10 | 7.5/12 | 7.5/13 | 11/17 | 15/24 | | | | |
| Rated operational current / power Category AC-1 (Resistance, heater load) | AC100 to 240V | 20 | | | 32 | | | 60 | | | 80 | |
| | AC380 to 440V | 11 | 13 | 13 | 32 | 32 | 60 | 60 | 80 | | | |
| | AC500 to 550V | 8 | 11 | 13 | 32 | 32 | 60 | 60 | 80 | | | |
| Conventional Free Air Thermal Current I _{th} [A] | | 20 | | | 32 | | | 60 | | | 80 | |
| Auxiliary contact rating | Contact Arrangement | Standard Accessory (Note 7) | Non-Reversing | 1a | 1a1b | 2a2b | — | 2a2b | 2a2b | 2a2b | | |
| | | Reversing (Note 8, Note 9) | 1a x 2 + 2b | 1a1b x 2 + 2b | 2a2b x 2 | — | 2a2b x 2 | 2a2b x 2 | 2a2b x 2 | | | |
| | Max. number of additional options (Note 11) | Non-Reversing | 1 for UT-AX2/4, 2 for UT-AX11 | | | | | | | | | |
| | | Reversing (Note 8, Note 9) | 2 for any UT-AX2/4/11 | | | | | | | — | 2 for any UT-AX2/4/11 | |
| | Rated Operating Current (Category AC-15: Alternating current coil load) [A] | | AC120V | 6 | 6 | 6 | 6 | 6 | 6 | 6 | 6 | |
| Rated Operational Current (Category DC-13 : Direct current coil load) | | DC24V | 3 | 3 | 3 | 3 | 3 | 3 | 3 | 3 | | |
| Conventional Free Air Thermal Current I _{th} [A] | | DC110V | 0.6 | | | | | | | | | |
| Performance | Mechanical Durability [x 10000] | | 1000 | | | | | | | | | |
| | Electrical Durability (Note 5) [Ten thousand times] | Category AC-3 | 200 (Note 5, 6) | | | | | | | | | |
| | | Category AC-4 | 3 (Note 5) | | | | | | | | | |
| | | Category AC-1 | 50 | | | | | | | | | |
| | Switching Frequency [Times/Hour] | Category AC-3 | 1800 | | | | | | | | 1200 | |
| Category AC-4 | | 300 | | | | | | | | | | |
| Category AC-1 | | 1200 | | | | | | | | | | |
| Characteristic | Coil consumption (Note7) [VA] | | Sealed | 7 | 7 | 7 | 4.5 | 10 | 10 | | | |
| | Power Consumption (Note 7) [W] | | Inrush | 45 | 75 | 75 | 55 | 110 | 110 | | | |
| Outside Dimensions | Magnetic Contactors (without Thermal Overload Relays) (Width x Height x Depth) [mm] | | Non-Reversing | 36 x 75 x 78 | 44 x 75 x 78 | 63 x 81 x 81 | 43 x 81 x 81 | 75 x 89 x 91 | | | | |
| | | | Reversing | 82 x 85 x 78 | 98 x 85 x 78 | 136 x 81 x 81 | 96 x 81 x 111 | 160 x 114 x 97 | | | | |
| | Open Type Magnetic Starters (Width x Height x Depth) [mm] | | Non-Reversing | 46 x 115 x 79 | | | 63 x 128 x 82 | — | 75 x 157.5 x 91 | | | |
| | | | Reversing | 90.5 x 125 x 79 | 98.5 x 125 x 79 | 136 x 138 x 82 | — | 160 x 179 x 97 | | | | |
| | Enclosed Magnetic Starters (Width x Height x Depth) [mm] | | Non-Reversing | 76 x 165 x 97.5 | | | 104 x 176 x 110 | — | 135 x 231 x 126 | | | |
| | | | Reversing | — | | | 220 x 192 x 115 | — | 300 x 247 x 130 | | | |
| IEC 35mm rail mounting | | | Possible (excluding Enclosed Magnetic Starters) | | | | | | | | | |
| Installable Optional Unit Model Names (Note 10) | Additional Auxiliary Contact Units | | UT-AX2/AX11 | | | | | | | | | |
| | | | UT-AX4 | | | | | | | | | |
| | With Low-Level Signal Contact | | — | | | | | | | | | |
| | (Varistor) (Note 4) | | UT-SA21 | | | | | | | | | |
| | Coil Surge Absorber Units (Note 4) | | UT-SA22 | | | | | | | | | |
| | | | UT-SA23 | | | | | | | | | |
| | | | UT-SA25 | | | | | | | | | |
| | DC-AC Interface | | Triac Output | | | | | | | | | |
| | | | Contact Output | | | | | | | | | |
| | | | UT-SY21 | | | | | | | | | |
| Live Part Protection Cover | For Magnetic Starters | Non-Reversing | — | | | | | | | | | |
| | | Reversing | — | | | | | | | | | |
| | For Magnetic Contactors | Non-Reversing | — | | | | | | | | | |
| | | Reversing | — | | | | | | | | | |
| Terminal Cover | For Magnetic Starters (Non-Reversing) | (Standard Equipment) | | | | | | | | | | |
| | For Magnetic Contactors (Non-Reversing) | (Standard Equipment) | | | | | | | | | | |
| Mechanical Interlock Units | | | UT-ML20 (Note 11) | | | UN-ML21 | | | | | | |

- Note 1. The figure in the square brackets indicates the rated current shown on the rating plate of the product at which the category AC-3 opening/closing durability.
- Note 2. The value between parentheses for the rated operating current is for the magnetic starter (with thermal overload relay).
- Note 3. AC operated types T10 to T50, DC operated types T12 to T50 can be manufactured with coil surge absorber (□-□SA type). The UT-SA21 type can be mounted.
- Note 4. T65 to N800 types have an integrated coil surge absorber rendering a coil surge absorber unit for prevention of coil switching surges unnecessary.
- Note 5. 1 million times for T20 class AC-3 380 V or more types for the rating in parentheses and 15,000 times for class AC-4 types. 15 thousand times for T35 to N800 class AC-4 380 V or more types.
- Note 6. Values are for the ratings in square brackets. The electrical durability for the current values not in parentheses varies inversely with the rough square of the current.
- Note 7. Mechanically latched types and delay open types have differing auxiliary contact arrangements. Refer to page 102 for details about mechanically latched types, or page 111 for delay open types.

| T65 | T80 | T100 | N125 | N150 | N180 | N220 | N300 | N400 | N600 | N800 |
|---|-------------------|--------------------|----------------------|----------------------|-----------------------|-------------------|-----------------------|-------------------|-------------------|-------------------|
| JIS C8201-4-1, IEC60947-4-1, EN60947-4-1, GB14048.4 | | | | | | | | | | |
| S-T65 | S-T80 | S-T100 | S-N125 | S-N150 | S-N180 | S-N220 | S-N300 | S-N400 | S-N600 | S-N800 |
| S-2 x T65 | S-2 x T80 | S-2 x T100 | S-2 x N125 | S-2 x N150 | S-2 x N180 | S-2 x N220 | S-2 x N300 | S-2 x N400 | S-2 x N600 | S-2 x N800 |
| MS-T65 | MS-T80 | MS-T100 | MS-N125 | MS-N150 | MS-N180 | MS-N220 | MS-N300 | MS-N400 | — | — |
| MS-2 x T65 | MS-2 x T80 | MS-2 x T100 | MS-2 x N125 | MS-2 x N150 | MS-2 x N180 | MS-2 x N220 | MS-2 x N300 | MS-2 x N400 | — | — |
| MSO-T65 | MSO-T80 | MSO-T100 | MSO-N125 | MSO-N150 | MSO-N180 | MSO-N220 | MSO-N300 | MSO-N400 | — | — |
| MSO-2 x T65 | MSO-2 x T80 | MSO-2 x T100 | MSO-2 x N125 | MSO-2 x N150 | MSO-2 x N180 | MSO-2 x N220 | MSO-2 x N300 | MSO-2 x N400 | — | — |
| TH-T65 | TH-T65 / T100 | TH-T65 / T100 | TH-N120(TA) | TH-N120(TA) | TH-N220RH | TH-N220RH | TH-N400RH | TH-N400RH | TH-N600(+CT) | TH-N600(+CT) |
| MS-T65KP | MS-T80KP | MS-T100KP | MS-N125KP | MS-N150KP | MS-N180KP | MS-N220KP | MS-N300KP | MS-N400KP | — | — |
| MS-2 x T65KP | MS-2 x T80KP | MS-2 x T100KP | MS-2 x N125KP | MS-2 x N150KP | MS-2 x N180KP | MS-2 x N220KP | MS-2 x N300KP | MS-2 x N400KP | — | — |
| MSO-T65KP | MSO-T80KP | MSO-T100KP | MSO-N125KP | MSO-N150KP | MSO-N180KP | MSO-N220KP | MSO-N300KP | MSO-N400KP | — | — |
| MSO-2 x T65KP | MSO-2 x T80KP | MSO-2 x T100KP | MSO-2 x N125KP | MSO-2 x N150KP | MSO-2 x N180KP | MSO-2 x N220KP | MSO-2 x N300KP | MSO-2 x N400KP | — | — |
| TH-T65KP | TH-T65 / T100KP | TH-T65 / T100KP | TH-N120(TA)KP | TH-N120(TA)KP | TH-N220RHKP | TH-N220RHKP | TH-N400RHKP | TH-N400RHKP | TH-N600KP(+CT) | TH-N600KP(+CT) |
| 690 | | | | | 690 (1000) | | | | | |
| 6 | | | | | 6 (8) | | | | | |
| 50/60 | | | | | | | | | | |
| 3 | | | | | | | | | | |
| 18.5/65 [15/65] | 22/85 [19/80] | 30/105 [22/100] | 37/125 [30/125] | 45/150 [37/150] | 55/180 [45/180] | 75/250 [55/220] | 90/300 [75/300] | 125/400 [110/400] | 190/630 [160/630] | 220/800 [200/800] |
| 30/65 [30/65] | 45/85 [37/80] | 55/105 [45/93] | 60/120 [60/120] | 75/150 [75/150] | 90/180 [90/180] | 132/250 [110/220] | 160/300 [150/300] | 220/400 [200/400] | 330/630 [300/630] | 440/800 [400/800] |
| 37/60 [30/45] | 45/75 [45/75] | 55/85 [45/75] | 60/90 [60/90] | 90/140 [90/140] | 110/180 [110/180] | 132/200 [132/200] | 160/250 [160/250] | 225/350 [200/350] | 330/500 [300/500] | 500/720 [400/720] |
| 30/38 | 45/52 | 55/65 | 60/70 | 90/100 | 110/120 | 132/150 | 200/220 | 250/300 | 330/420 | 500/630 |
| 11/50 | 15/65 | 19/80 | 22/93 | 30/125 | 37/150 | 45/180 | 55/220 | 75/300 | 110/400 | 160/630 |
| 22/47 | 30/62 | 37/75 | 45/90 | 55/110 | 75/150 | 90/180 | 110/220 | 150/300 | 200/400 | 300/630 |
| 22/38 | 30/45 | 37/55 | 45/65 | 55/80 | 75/140 | 90/140 | 110/200 | 150/250 | 200/350 | 300/500 |
| 100 | 120 | 150 | 150 | 200 | 260 | 260 | 350 | 450 | 660 | 800 |
| 100 | 120 | 150 | 150 | 200 | 260 | 260 | 350 | 450 | 660 | 800 |
| 100 | 120 | 150 | 150 | 200 | 260 | 260 | 350 | 450 | 660 | 800 |
| 100 | 120 | 150 | 150 | 200 | 260 | 260 | 350 | 450 | 660 | 800 |
| 2a2b | 2a2b | 2a2b | 2a2b | 2a2b | 2a2b | 2a2b | 2a2b | 2a2b | 2a2b | 2a2b |
| 2a2b x 2 | 2a2b x 2 | 2a2b x 2 | 2a2b x 2 | 3a3b x 2 | 3a3b x 2 | 3a3b x 2 | 3a3b x 2 | 3a3b x 2 | 4a4b x 2 | 4a4b x 1 |
| 1 for UT-AX2/4, 2 for UT-AX11 | | 2 for UN-AX80 | | | 2 for UN-AX150 | | | | 1 for UN-AX600 | |
| 2 for any UT-AX2/4/11 | | 2 for UN-AX80 | | | — | — | — | — | — | — |
| 6 | 6 | 6 | 6 | 6 | 6 | 6 | 6 | 6 | 6 | 6 |
| 3 | 3 | 3 | 3 | 3 | 3 | 3 | 3 | 3 | 3 | 3 |
| 3 | | 3 | | | 3 | | | | 3 | |
| 0.6 | | | | | | | | | | |
| 10 | 10 | 10 | 10 | 10 | 10 | 10 | 10 | 10 | 10 | 10 |
| 500 | | | | | | | | | | |
| 200 | 100 (Note 6) | | | | | | | 50 (Note 6) | | |
| 3 (Note 5) | | | | | | | | | | |
| 50 | | | | | | | | | | |
| 1200 | | | | | | | | | | |
| 300 | | | | | | | | | | |
| 1200 | | 600 | | | | | | | | |
| 20 | 23 | 24 | 24 | 40 | 40 | 50 | 50 | 90 | 90 | |
| 115 | 210 | 270 | 270 | 440 | 440 | 440 | 440 | 790 | 790 | |
| 2.2 | 2.2 | 2.8 | 2.9 | 2.9 | 4.2 | 4.2 | 6.1 | 6.1 | 17 | |
| 88 x 106 x 106 | 88 x 106 x 106 | 100 x 124 x 127 | 100 x 150 x 137 | 120 x 160 x 145 | 138 x 204 x 175 | 138 x 204 x 175 | 163 x 243 x 195 | 163 x 243 x 195 | 290 x 310 x 235 | 290 x 310 x 235 |
| 216 x 115 x 112 | 216 x 115 x 112 | 270 x 140 x 137 | 276 x 150 x 148 | 296 x 160 x 156 | 370 x 215 x 189 | 370 x 215 x 189 | 395 x 250 x 209 | 395 x 250 x 209 | 660 x 435 x 254 | 660 x 435 x 254 |
| 90 x 158 x 106 | 90 x 174.5 x 106 | 100 x 196 x 127 | 112 x 239 x 137 | 120 x 250 x 145 | 144 x 282 x 180.5 | 144 x 282 x 180.5 | 163 x 360 x 195 | 163 x 360 x 195 | — | — |
| 216 x 169 x 112 | 216 x 185.5 x 112 | 270 x 213 x 137 | 276 x 251 x 148 | 296 x 276 x 156 | 370 x 304 x 194.5 | 370 x 304 x 194.5 | 395 x 392 x 209 | 395 x 392 x 209 | — | — |
| 160 x 282 x 145 | 190 x 317 x 163 | 230 x 396 x 190 | — | — | 270 x 496 x 209 | — | — | — | — | — |
| 320 x 282 x 140 | 410 x 347 x 154 | 440 x 436 x 170 | — | — | 520 x 536 x 209 | — | — | 600 x 616 x 230 | — | — |
| Possible (excluding Enclosed Magnetic Starters) | | | | | | | | | | |
| UN-AX2/AX11 | | UN-AX80 | | | UN-AX150 | | | | UN-AX600 | |
| UN-AX4 | | — | | | — | | | | — | |
| UN-LL22 | | — | | | — | | | | — | |
| — | | — | | | — | | | | — | |
| — | | — | | | — | | | | — | |
| — | | — | | | — | | | | — | |
| UN-SY31 | | — | | | — | | | | — | |
| UN-SY32 | | — | | | — | | | | — | |
| UN-CZ500 + UN-CZ501 | | UN-CZ800+ UN-CZ801 | UN-CZ1250+ UN-CZ1251 | UN-CZ1500+ UN-CZ1501 | UN-CZ2200 + UN-CZ2201 | | UN-CZ3000 + UN-CZ3001 | | — | — |
| UN-CZ504 | | UN-CZ804 | UN-CZ1254 | UN-CZ1504 | UN-CZ2204 | | UN-CZ3004 | | — | — |
| UN-CZ500 x 2 | | UN-CZ800 x 2 | UN-CZ1250 x 2 | UN-CZ1500 x 2 | UN-CZ2200 x 2 | | UN-CZ3000 x 2 | | — | — |
| UN-CZ502 | | UN-CZ802 | UN-CZ1252 | UN-CZ1502 | UN-CZ2202 | | UN-CZ3002 | | — | — |
| UT-CW800 + UT-CW655 | | — | | | — | | | | — | |
| UT-CW800 | | — | | | — | | | | — | |
| UN-ML21 | | UN-ML80 | | UN-ML150 | UN-ML220 | | | | | |

Note 8. The +2b on the auxiliary contact arrangement of reversible T10 to T20 types indicates the break contact of the integrated UT-ML20 interlock unit.

There is no need to specify when ordering.

Note 9. Auxiliary contact arrangements for reversible types are displayed by twos, in a contact arrangement combined with two magnetic contactors. For standard contact arrangements there is no need to specify the ordering; however, please specify a matching contact arrangement for 2 units if for a special configuration. <Example> For 1b x 2 + 2b: 2B

Note 10. Because there are products that cannot be mounted, please refer to combination details on page 192 when applying optional products.

Note 11. Not applicable to AC operated types produced before March, 2019.

2.2 Manufacturing Range List

● Non-Reversible Type

| Frame | | T10 | T12 | T20 | T21 | T25 | T32 | T35 | T50 | T65 | T80 | T100 | N125 | N150 | N180 | N220 | N300 | N400 | N600 | N800 | | | | |
|-------------------------------|------------------------------|---|----------------|----------------|--------|-----|--------|------|-----|------|-----|------|------|------|------|------|------|------|------|------|---|---|---|---|
| Category AC-3 | 220V | 2.5 | 3.5 | 4.5 | 5.5 | 7.5 | 7.5 | 11 | 15 | 18.5 | 22 | 30 | 37 | 45 | 55 | 75 | 90 | 125 | 190 | 220 | | | | |
| Rated Capacity [kW] | 440V | 4 | 5.5 | 7.5 | 11 | 15 | 15 | 18.5 | 22 | 30 | 45 | 55 | 60 | 75 | 90 | 132 | 160 | 220 | 330 | 440 | | | | |
| Auxiliary Contact (Note 6) | Standard | 1a | 1a1b | 1a1b | ←2a2b→ | | ←2a2b→ | | | | | | | | | | | | | | | | | |
| | Special | 1b | 2a (Note 8) | 2a (Note 8) | — | — | — | — | — | — | — | — | — | — | — | — | — | — | — | — | — | | | |
| Model Name | | | | | | | | | | | | | | | | | | | | | | | | |
| Magnetic Starters | Enclosed | Standard Specifications | MS-□ | ○ | ○ | — | ○ | — | — | ○ | ○ | ○ | ○ | ○ | ○ | ○ | ○ | ○ | ○ | ○ | ○ | — | — | |
| | | With Push-Button | MS-□PM | ○ | ○ | — | ○ | — | — | ○ | ○ | ○ | ○ | ○ | — | — | — | — | — | — | — | — | — | — |
| | | 3-Element (2E) Thermal | MS-□KP | ○ | ○ | — | ○ | — | — | ○ | ○ | ○ | ○ | ○ | ○ | ○ | ○ | ○ | ○ | ○ | ○ | ○ | — | — |
| | | Open Time Quick Motion Type | MS-□QM | — | — | — | — | — | — | — | ○ | ○ | ○ | ○ | ○ | ○ | ○ | ○ | ○ | ○ | ○ | ○ | — | — |
| | Open Type | Standard Specifications | MSO-□ | ○ | ○ | ○ | ○ | ○ | — | ○ | ○ | ○ | ○ | ○ | ○ | ○ | ○ | ○ | ○ | ○ | ○ | ○ | — | — |
| | | | MSOD-□ | — | ○ | ○ | ○ | — | — | ○ | ○ | ○ | ○ | ○ | ○ | ○ | — | ○ | ○ | ○ | ○ | ○ | — | — |
| | | 3-Element (2E) Thermal | MSO-□KP | ○ | ○ | ○ | ○ | ○ | — | ○ | ○ | ○ | ○ | ○ | ○ | ○ | ○ | ○ | ○ | ○ | ○ | ○ | — | — |
| | | | MSOD-□KP | — | ○ | ○ | ○ | — | — | ○ | ○ | ○ | ○ | ○ | ○ | ○ | — | ○ | ○ | ○ | ○ | ○ | — | — |
| | | With Saturable Reactor | MSO-□SR | ○ | ○ | ○ | ○ | ○ | — | ○ | ○ | ○ | ○ | ○ | ○ | ○ | ○ | ○ | ○ | ○ | ○ | ○ | — | — |
| | | | MSOD-□SR | — | ○ | ○ | ○ | — | — | ○ | ○ | ○ | ○ | ○ | ○ | ○ | — | ○ | ○ | ○ | ○ | ○ | — | — |
| | | With 3-Element (2E) Thermal Saturable Reactor | MSO-□KPSR | — | — | — | ○ | ○ | — | ○ | ○ | ○ | ○ | ○ | ○ | ○ | ○ | ○ | ○ | ○ | ○ | ○ | — | — |
| | | | MSOD-□KPSR | — | — | — | ○ | — | — | ○ | ○ | ○ | ○ | ○ | ○ | ○ | — | ○ | ○ | ○ | ○ | ○ | — | — |
| | | 2-Element Quick-acting Characteristics Thermal | MSO-□FS | — | — | — | ○ | ○ | — | ○ | ○ | ○ | ○ | ○ | — | — | — | — | — | — | — | — | — | — |
| | | | MSOD-□FS | — | — | — | ○ | — | — | ○ | ○ | ○ | ○ | ○ | — | — | — | — | — | — | — | — | — | — |
| | | 3-Element (2E) Quick-acting Characteristics Thermal | MSO-□FSKP | ○ | ○ | ○ | ○ | ○ | — | ○ | ○ | ○ | ○ | ○ | — | — | — | — | — | — | — | — | — | — |
| | | | MSOD-□FSKP | — | ○ | ○ | ○ | — | — | ○ | ○ | ○ | ○ | ○ | — | — | — | — | — | — | — | — | — | — |
| | | Open Time Quick Motion Type | MSO-□QM | — | — | — | — | — | — | — | — | ○ | ○ | ○ | ○ | ○ | ○ | ○ | ○ | ○ | ○ | ○ | — | — |
| | | | MSOD-□QM | — | — | — | — | — | — | — | — | ○ | ○ | ○ | ○ | ○ | ○ | ○ | ○ | ○ | ○ | ○ | — | — |
| | | Surge Absorber Mounted Type | MSO-□SA | ○ | ○ | ○ | ○ | ○ | — | ○ | ○ | — | — | — | — | — | — | — | — | — | — | — | — | — |
| | | | MSOD-□SA | — | ○ | ○ | ○ | — | — | ○ | ○ | — | — | — | — | — | — | — | — | — | — | — | — | — |
| | Wiring Streamlining Terminal | MSO-□BC | ○ | ○ | ○ | ○ | ○ | — | ○ | ○ | — | — | — | — | — | — | — | — | — | — | — | — | — | |
| | | MSOD-□BC | — | ○ | ○ | ○ | — | — | ○ | ○ | — | — | — | — | — | — | — | — | — | — | — | — | — | |
| | Anticorrosion Treatment | MSO-□YS | ○ | ○ | ○ | ○ | ○ | — | ○ | ○ | ○ | ○ | ○ | ○ | ○ | ○ | ○ | ○ | ○ | ○ | ○ | — | — | |
| | | MSOD-□YS | — | ○ | ○ | ○ | — | — | ○ | ○ | ○ | ○ | ○ | ○ | ○ | — | ○ | ○ | ○ | ○ | ○ | — | — | |
| | Delay Open Type | MSO-□DL | — | ○ | — | ○ | — | — | ○ | ○ | ○ | ○ | ○ | — | ○ | — | ○ | ○ | ○ | ○ | ○ | — | — | |
| | | MSOD-□DL | — | ○ | — | ○ | — | — | ○ | ○ | ○ | ○ | ○ | — | ○ | — | ○ | ○ | ○ | ○ | ○ | — | — | |
| | Mechanically Latched Type | MSOL-□ | — | — | — | ○ | — | — | ○ | ○ | ○ | ○ | ○ | ○ | ○ | — | ○ | ○ | ○ | ○ | ○ | — | — | |
| | | MSOLD-□ | — | — | — | ○ | — | — | ○ | ○ | ○ | ○ | ○ | ○ | ○ | — | ○ | ○ | ○ | ○ | ○ | — | — | |
| With Terminal Cover | MSO-□CW | — | — | — | — | — | — | — | — | ○ | ○ | ○ | ○ | ○ | ○ | ○ | ○ | ○ | ○ | ○ | — | — | | |
| | MSOD-□CW | — | — | — | — | — | — | — | — | ○ | ○ | ○ | ○ | ○ | ○ | ○ | ○ | ○ | ○ | ○ | — | — | | |
| Magnetic Contactors | Open Type | Standard Specifications | S-□ | ○ | ○ | ○ | ○ | ○ | ○ | ○ | ○ | ○ | ○ | ○ | ○ | ○ | ○ | ○ | ○ | ○ | ○ | ○ | ○ | |
| | | | SD-□ | — | ○ | ○ | ○ | — | ○ | ○ | ○ | ○ | ○ | ○ | ○ | ○ | — | ○ | ○ | ○ | ○ | ○ | ○ | |
| | | Surge Absorber Mounted Type | S-□SA(Note3) | ○ | ○ | ○ | ○ | ○ | ○ | ○ | ○ | — | — | — | — | — | — | — | — | — | — | — | — | — |
| | | | SD-□SA | — | ○ | ○ | ○ | — | ○ | ○ | ○ | — | — | — | — | — | — | — | — | — | — | — | — | — |
| | | Anticorrosion Treatment | S-□YS | — | — | — | — | — | — | ○ | ○ | ○ | ○ | ○ | ○ | ○ | ○ | ○ | ○ | ○ | ○ | ○ | ○ | ○ |
| | | | S-□QM | — | — | — | — | — | — | — | — | ○ | ○ | ○ | ○ | ○ | ○ | ○ | ○ | ○ | ○ | ○ | — | — |
| | | Wiring Streamlining Terminal | S-□BC | ○ | ○ | ○ | ○ | ○ | ○ | ○ | ○ | — | — | — | — | — | — | — | — | — | — | — | — | — |
| | | | SD-□BC | — | ○ | ○ | ○ | — | ○ | ○ | ○ | — | — | — | — | — | — | — | — | — | — | — | — | — |
| | | With Spring Clamp Terminals | S-□SQ | — | ○ | ○ | — | — | — | — | — | — | — | — | — | — | — | — | — | — | — | — | — | — |
| | | | SD-□SQ | — | ○ | ○ | — | — | — | — | — | — | — | — | — | — | — | — | — | — | — | — | — | — |
| | | With Terminal Cover | S-□CW | — | — | — | — | — | — | — | — | ○ | ○ | ○ | ○ | ○ | ○ | ○ | ○ | ○ | ○ | ○ | — | — |
| | | | SD-□CW | — | — | — | — | — | — | — | — | ○ | ○ | ○ | ○ | ○ | ○ | ○ | ○ | ○ | ○ | ○ | — | — |
| Delay Open Type | S-□DL | — | ○ | — | ○ | — | — | ○ | ○ | ○ | ○ | ○ | — | ○ | — | ○ | ○ | ○ | ○ | ○ | — | — | | |
| | SD-□DL | — | ○ | — | ○ | — | — | ○ | ○ | ○ | ○ | ○ | — | ○ | — | ○ | ○ | ○ | ○ | ○ | — | — | | |
| Mechanically Latched Type | SL-□ | — | — | — | ○ | — | — | ○ | ○ | ○ | ○ | ○ | ○ | ○ | — | ○ | ○ | ○ | ○ | ○ | ○ | ○ | | |
| | SLD-□ | — | — | — | ○ | — | — | ○ | ○ | ○ | ○ | ○ | ○ | ○ | — | ○ | ○ | ○ | ○ | ○ | ○ | ○ | | |

● Reversible Type

| Frame | | 2 x T10 | 2 x T12 | 2 x T20 | 2 x T21 | 2 x T25 | 2 x T32 | 2 x T35 | 2 x T50 | 2 x T65 | 2 x T80 | 2 x T100 | 2 x N125 | 2 x N150 | 2 x N180 | 2 x N220 | 2 x N300 | 2 x N400 | 2 x N600 | 2 x N800 | | |
|--------------------------------------|---|---------------|-----------------|----------|---------|---------|---------|---------|---------|---------|---------|----------|----------|----------|----------|----------|----------|----------|----------|----------|-----|---|
| Category AC-3 | 220V | 2.5 | 3.5 | 4.5 | 5.5 | 7.5 | 7.5 | 11 | 15 | 18.5 | 22 | 30 | 37 | 45 | 55 | 75 | 90 | 125 | 190 | 220 | | |
| | Rated Capacity [kW] | 440V | 4 | 5.5 | 7.5 | 11 | 15 | 15 | 18.5 | 22 | 30 | 45 | 55 | 60 | 75 | 90 | 132 | 160 | 220 | 330 | 440 | |
| Auxiliary Contact (Note 4 to Note 6) | Standard | (1a x 2) + 2b | (1a1b x 2) + 2b | 2a2b x 2 | | | | | | | | | | 3a3b x 2 | | | | | 4a4b x 2 | | | |
| | Special | (1b x 2) + 2b | (2a x 2) + 2b | - | - | - | - | - | - | - | - | - | - | - | - | - | - | - | - | - | - | |
| Model | Standard Specifications | MS-□ | ○ | ○ | ○ | ○ | ○ | ○ | ○ | ○ | ○ | ○ | ○ | ○ | ○ | ○ | ○ | ○ | ○ | ○ | ○ | |
| Magnetic Starters | 3-Element (2E) Thermal | MS-□KP | ○ | ○ | ○ | ○ | ○ | ○ | ○ | ○ | ○ | ○ | ○ | ○ | ○ | ○ | ○ | ○ | ○ | ○ | ○ | |
| | Standard Specifications | MSO-□ | ◎ | ◎ | ◎ | ◎ | ◎ | ◎ | ◎ | ◎ | ◎ | ◎ | ◎ | ◎ | ◎ | ◎ | ◎ | ◎ | ◎ | ◎ | ◎ | |
| | 3-Element (2E) Thermal | MSO-□KP | ○ | ○ | ○ | ○ | ○ | ○ | ○ | ○ | ○ | ○ | ○ | ○ | ○ | ○ | ○ | ○ | ○ | ○ | ○ | ○ |
| | | MSOD-□KP | ○ | ○ | ○ | ○ | ○ | ○ | ○ | ○ | ○ | ○ | ○ | ○ | ○ | ○ | ○ | ○ | ○ | ○ | ○ | ○ |
| | With Saturable Reactor | MSO-□SR | ○ | ○ | ○ | ○ | ○ | ○ | ○ | ○ | ○ | ○ | ○ | ○ | ○ | ○ | ○ | ○ | ○ | ○ | ○ | ○ |
| | | MSOD-□SR | ○ | ○ | ○ | ○ | ○ | ○ | ○ | ○ | ○ | ○ | ○ | ○ | ○ | ○ | ○ | ○ | ○ | ○ | ○ | ○ |
| | With 3-Element (2E) Thermal Saturable Reactor | MSO-□KPSR | ○ | ○ | ○ | ○ | ○ | ○ | ○ | ○ | ○ | ○ | ○ | ○ | ○ | ○ | ○ | ○ | ○ | ○ | ○ | ○ |
| | | MSOD-□KPSR | ○ | ○ | ○ | ○ | ○ | ○ | ○ | ○ | ○ | ○ | ○ | ○ | ○ | ○ | ○ | ○ | ○ | ○ | ○ | ○ |
| | 2-Element Quick-acting Characteristics Thermal | MSO-□FS | ○ | ○ | ○ | ○ | ○ | ○ | ○ | ○ | ○ | ○ | ○ | ○ | ○ | ○ | ○ | ○ | ○ | ○ | ○ | ○ |
| | | MSOD-□FS | ○ | ○ | ○ | ○ | ○ | ○ | ○ | ○ | ○ | ○ | ○ | ○ | ○ | ○ | ○ | ○ | ○ | ○ | ○ | ○ |
| | 3-Element (2E) Quick-acting Characteristics Thermal | MSO-□FSKP | ○ | ○ | ○ | ○ | ○ | ○ | ○ | ○ | ○ | ○ | ○ | ○ | ○ | ○ | ○ | ○ | ○ | ○ | ○ | ○ |
| | | MSOD-□FSKP | ○ | ○ | ○ | ○ | ○ | ○ | ○ | ○ | ○ | ○ | ○ | ○ | ○ | ○ | ○ | ○ | ○ | ○ | ○ | ○ |
| | Surge Absorber Mounted Type | MSO-□SA | ○ | ○ | ○ | ○ | ○ | ○ | ○ | ○ | ○ | ○ | ○ | ○ | ○ | ○ | ○ | ○ | ○ | ○ | ○ | ○ |
| | | MSOD-□SA | ○ | ○ | ○ | ○ | ○ | ○ | ○ | ○ | ○ | ○ | ○ | ○ | ○ | ○ | ○ | ○ | ○ | ○ | ○ | ○ |
| | Wiring Streamlining Terminal | MSO-□BC | ○ | ○ | ○ | ○ | ○ | ○ | ○ | ○ | ○ | ○ | ○ | ○ | ○ | ○ | ○ | ○ | ○ | ○ | ○ | ○ |
| | | MSOD-□BC | ○ | ○ | ○ | ○ | ○ | ○ | ○ | ○ | ○ | ○ | ○ | ○ | ○ | ○ | ○ | ○ | ○ | ○ | ○ | ○ |
| | With Terminal Cover | MSO-□CW | ○ | ○ | ○ | ○ | ○ | ○ | ○ | ○ | ○ | ○ | ○ | ○ | ○ | ○ | ○ | ○ | ○ | ○ | ○ | ○ |
| | | MSOD-□CW | ○ | ○ | ○ | ○ | ○ | ○ | ○ | ○ | ○ | ○ | ○ | ○ | ○ | ○ | ○ | ○ | ○ | ○ | ○ | ○ |
| | Anticorrosion Treatment | MSO-□YS | ○ | ○ | ○ | ○ | ○ | ○ | ○ | ○ | ○ | ○ | ○ | ○ | ○ | ○ | ○ | ○ | ○ | ○ | ○ | ○ |
| | | MSOD-□YS | ○ | ○ | ○ | ○ | ○ | ○ | ○ | ○ | ○ | ○ | ○ | ○ | ○ | ○ | ○ | ○ | ○ | ○ | ○ | ○ |
| Mechanically Latched Type | MSOL-□ | ○ | ○ | ○ | ○ | ○ | ○ | ○ | ○ | ○ | ○ | ○ | ○ | ○ | ○ | ○ | ○ | ○ | ○ | ○ | ○ | |
| | MSOLD-□ | ○ | ○ | ○ | ○ | ○ | ○ | ○ | ○ | ○ | ○ | ○ | ○ | ○ | ○ | ○ | ○ | ○ | ○ | ○ | ○ | |
| Magnetic Contactors | Standard Specifications | S-□ | ◎ | ◎ | ◎ | ◎ | ◎ | ◎ | ◎ | ◎ | ◎ | ◎ | ◎ | ◎ | ◎ | ◎ | ◎ | ◎ | ◎ | ◎ | ◎ | |
| | Surge Absorber Mounted Type | SD-□ | ○ | ○ | ○ | ○ | ○ | ○ | ○ | ○ | ○ | ○ | ○ | ○ | ○ | ○ | ○ | ○ | ○ | ○ | ○ | ○ |
| | | S-□SA(Note 3) | ○ | ○ | ○ | ○ | ○ | ○ | ○ | ○ | ○ | ○ | ○ | ○ | ○ | ○ | ○ | ○ | ○ | ○ | ○ | ○ |
| | Anticorrosion Treatment | SD-□SA | ○ | ○ | ○ | ○ | ○ | ○ | ○ | ○ | ○ | ○ | ○ | ○ | ○ | ○ | ○ | ○ | ○ | ○ | ○ | ○ |
| | | S-□YS | ○ | ○ | ○ | ○ | ○ | ○ | ○ | ○ | ○ | ○ | ○ | ○ | ○ | ○ | ○ | ○ | ○ | ○ | ○ | ○ |
| | Wiring Streamlining Terminal | S-□BC | ○ | ○ | ○ | ○ | ○ | ○ | ○ | ○ | ○ | ○ | ○ | ○ | ○ | ○ | ○ | ○ | ○ | ○ | ○ | ○ |
| | | SD-□BC | ○ | ○ | ○ | ○ | ○ | ○ | ○ | ○ | ○ | ○ | ○ | ○ | ○ | ○ | ○ | ○ | ○ | ○ | ○ | ○ |
| | With Terminal Cover | S-□CW | ○ | ○ | ○ | ○ | ○ | ○ | ○ | ○ | ○ | ○ | ○ | ○ | ○ | ○ | ○ | ○ | ○ | ○ | ○ | ○ |
| | | SD-□CW | ○ | ○ | ○ | ○ | ○ | ○ | ○ | ○ | ○ | ○ | ○ | ○ | ○ | ○ | ○ | ○ | ○ | ○ | ○ | ○ |
| | Mechanically Latched Type | SL-□ | ○ | ○ | ○ | ○ | ○ | ○ | ○ | ○ | ○ | ○ | ○ | ○ | ○ | ○ | ○ | ○ | ○ | ○ | ○ | ○ |
| | | SLD-□ | ○ | ○ | ○ | ○ | ○ | ○ | ○ | ○ | ○ | ○ | ○ | ○ | ○ | ○ | ○ | ○ | ○ | ○ | ○ | ○ |
| | Class 2 Heat Resistance | S-□FN | ○ | ○ | ○ | ○ | ○ | ○ | ○ | ○ | ○ | ○ | ○ | ○ | ○ | ○ | ○ | ○ | ○ | ○ | ○ | ○ |
| | With Reversing Connecting Conductor (Both Power and Load Sides) | S-□SD | ○ | ○ | ○ | ○ | ○ | ○ | ○ | ○ | ○ | ○ | ○ | ○ | ○ | ○ | ○ | ○ | ○ | ○ | ○ | ○ |
| | | SD-□SD | ○ | ○ | ○ | ○ | ○ | ○ | ○ | ○ | ○ | ○ | ○ | ○ | ○ | ○ | ○ | ○ | ○ | ○ | ○ | ○ |
| | With Power Side 3-Pole In-Phase Crossover Conductor | S-□SG | ○ | ○ | ○ | ○ | ○ | ○ | ○ | ○ | ○ | ○ | ○ | ○ | ○ | ○ | ○ | ○ | ○ | ○ | ○ | ○ |
| | | SD-□SG | ○ | ○ | ○ | ○ | ○ | ○ | ○ | ○ | ○ | ○ | ○ | ○ | ○ | ○ | ○ | ○ | ○ | ○ | ○ | ○ |
| | With Load Side 3-Pole In-Phase Crossover Conductor | S-□SX | ○ | ○ | ○ | ○ | ○ | ○ | ○ | ○ | ○ | ○ | ○ | ○ | ○ | ○ | ○ | ○ | ○ | ○ | ○ | ○ |
| | | SD-□SX | ○ | ○ | ○ | ○ | ○ | ○ | ○ | ○ | ○ | ○ | ○ | ○ | ○ | ○ | ○ | ○ | ○ | ○ | ○ | ○ |
| | With Load Side 3-Pole Reverse-Phase Switching Crossover Conductor | S-□SF | ○ | ○ | ○ | ○ | ○ | ○ | ○ | ○ | ○ | ○ | ○ | ○ | ○ | ○ | ○ | ○ | ○ | ○ | ○ | ○ |
| | | SD-□SF | ○ | ○ | ○ | ○ | ○ | ○ | ○ | ○ | ○ | ○ | ○ | ○ | ○ | ○ | ○ | ○ | ○ | ○ | ○ | ○ |

- Note 1. ◎ : Permanently in stock, depending on operation coil voltage and heater designation. ○ : Made to order.
 - : Outside production range
- Note 2. The value between parentheses for the class AC-3 rated capacity applies to an enclosed magnetic starter.
- Note 3. T65 to N800 types have an AC control coil integrated surge absorber, rendering a coil surge absorber unit for prevention of coil switching surges unnecessary.
- Note 4. The +2b on the auxiliary contact arrangement of reversible T10 to T20 types indicates the break contact of the integrated UT-ML20 interlock unit. There is no need to specify when ordering.
- Note 5. Auxiliary contact arrangements for reversible types are displayed by twos, in a contact arrangement combining two magnetic contactors. For standard contact arrangements there is no need to specify when ordering; however, please specify a matching contact arrangement for 2 units if for a special configuration.
 <Example> For 1b x 2 + 2b: 2B
- Note 6. Mechanically latched types and delay open types have differing auxiliary contact arrangements. Refer to page 102 for details about mechanically latched types, or page 111 for delay open types.
- Note 7. MSO(D)-(2x)T80CW(KP) heater designation 67A is not manufactured.
- Note 8. S-T12/T20 auxiliary contact 2b can be manufactured.

4.3 MSOD/SD-□ DC Operated Magnetic Starters/Magnetic Contactors

The operation coil is dedicated for DC

- The operation coil can be used with a separate power supply for DC operation.
(Main circuit can use both AC and DC)
- Electromagnet buzzing does not occur.
- The coil doesn't use saving resistance so there is no inrush current.
(Excluding N600, N800)
- SD-T12 to T32 and SD-N600, N800 type operation coil terminals have polarity.
Connect terminal number A1 (+) to the positive and A2 (-) to the negative sides.



SD-N220

● Ratings/Specifications (Standard Applicability)

| Magnetic Contactors | Magnetic Starters (Note 10) | Rated Capacity [kW] | | | | Rated Operating Current [A] | | | | | | Conventional Free Air Thermal Current Ith [A] | Auxiliary Contact | | Compatible Thermal Overload Relays | |
|---------------------|-----------------------------|---|----------------|----------|---------|---|----------------|----------|---------|--------------------------------|----------------|---|--------------------|--------------------------------------|------------------------------------|------------------------------|
| | | Three-Phase Squirrel-cage Motor (Category AC-3) | | | | Three-Phase Squirrel-cage Motor (Category AC-3) | | | | Resistive Load (Category AC-1) | | | Standard (Special) | Additional Unit Model Names x Pieces | Model Name | Heater Designation Range [A] |
| | | AC220 to 240 V | AC380 to 440 V | AC500 V | AC690 V | AC220 to 240 V | AC380 to 440 V | AC500 V | AC690 V | AC100 to 240 V | AC380 to 440 V | | | | | |
| SD-T12(BC) | MSOD-T12(BC)KP | 3.5[2.7] | 5.5[4] | 5.5[5.5] | 5.5 | 13[13] | 12[9] | 9[9] | 7 | 20 | 13 | 20 | 1a1b(2a) | UT-AX2, 4(BC) x 1 or UT-AX11(BC) x 2 | TH-T18(BC)KP | 0.12 to 11 |
| SD-T20(BC) | MSOD-T20(BC)KP | 4.5[3.7] | 7.5[7.5] | 7.5[7.5] | 7.5 | 18[18] | 18[18] | 17[17] | 9 | 20 | 18 | 20 | 2a2b | | TH-T25(BC)KP | 0.12 to 15 |
| SD-T21(BC) | MSOD-T21(BC)KP | 5.5[4] | 11[7.5] | 11[7.5] | 7.5 | 25[20] | 23[20] | 17[17] | 9 | 32 | 32 | 32 | — | | — | — |
| SD-T32(BC) | — | 7.5[7.5] | 15[15] | 15[11] | 11 | 32[32] | 32[32] | 24[20] | 12 | 32 | 32 | 32 | — | — | — | — |
| SD-T35(BC) | MSOD-T35(BC)KP | 11[7.5] | 18.5[15] | 18.5[15] | 15 | 40[35] | 40[32] | 32[26] | 17 | 60 | 60 | 60 | 2a2b | UN-AX2, 4 x 1 or UN-AX11 x 2 | TH-T25(BC)KP | 0.24 to 22 |
| SD-T50(BC) | MSOD-T50(BC)KP | 15[11] | 22[22] | 25[22] | 22 | 55[50] ^(Note 1) | 50[48] | 38[38] | 26 | 80 | 80 | 80 | | | TH-T50(BC)KP | 29 |
| SD-T65(CW) | MSOD-T65(CW)KP | 18.5[15] | 30[30] | 37[30] | 30 | 65[65] | 65[65] | 60[45] | 38 | 100 | 100 | 100 | | | TH-T25(BC)KP | 0.24 to 22 |
| SD-T80(CW) | MSOD-T80(CW)KP (Note 8) | 22[19] | 45[37] | 45[45] | 45 | 85[80] | 85[80] | 75[75] | 52 | 120 | 120 | 120 | | | TH-T50(BC)KP | 29 to 42 |
| SD-T100 | MSOD-T100KP | 30[22] | 55[45] | 55[45] | 55 | 105[100] | 105[93] | 85[75] | 65 | 150 | 150 | 150 | UN-AX80 x 2 | TH-T65KP | 15 to 54 | |
| SD-N125 | MSOD-N125KP | 37[30] | 60[60] | 60[60] | 60 | 125[125] | 120[120] | 90[90] | 70 | 150 | 150 | 150 | | TH-T100KP | 67, 82 | |
| SD-N150 | MSOD-N150KP | 45[37] | 75[75] | 90[90] | 90 | 150[150] | 150[150] | 140[140] | 100 | 200 | 200 | 200 | 2a2b | UN-AX150 x 2 | TH-N120KP (TA) | 42 to 105 |
| SD-N180 | MSOD-N180KP | 55[45] | 90[90] | 110[110] | 110 | 180[180] | 180[180] | 180[180] | 120 | 260 | 260 | 260 | | | TH-N220KPRH | 82 to 150 |
| SD-N220 | MSOD-N220KP | 75[55] | 132[110] | 132[132] | 132 | 250[220] | 250[220] | 200[200] | 150 | 260 | 260 | 260 | | | TH-N400KPRH | 105 to 250 |
| SD-N300 | MSOD-N300KP | 90[75] | 160[150] | 160[160] | 200 | 300[300] | 300[300] | 250[250] | 220 | 350 | 350 | 350 | | | TH-N600KP (Note 4) | 250 to 600 |
| SD-N400 | MSOD-N400KP | 125[110] | 220[200] | 225[200] | 250 | 400[400] | 400[400] | 350[350] | 300 | 450 | 450 | 450 | UN-AX600 x 1 | TH-N600KP (Note 4) | 250 to 500 | |
| SD-N600 | — | 190[160] | 330[300] | 330[300] | 330 | 630[630] | 630[630] | 500[500] | 420 | 660 | 660 | 660 | | | 250 to 600 | |
| SD-N800 | — | 220[200] | 440[400] | 500[400] | 500 | 800[800] | 800[800] | 720[720] | 630 | 800 | 800 | 800 | | | | |

Note 1. The value in parentheses for the rated operating current is applicable in the case of magnetic contactors.

Note 2. Enclosed types are not manufactured.

Note 3. Also manufactured as reversible types (MSOD-2x□ types excluding SD-2x□, T32 and N600/N800).

Note 4. Use TH-N600 in combination with a separately sold current transformer (Mitsubishi CW-□).

Note 5. The magnetic starters listed below are also manufactured.

- Models with 2E Thermal Overload Relay: MSOD-T12KP to T100KP, MSOD-N125KP to N400KP
- Models with Quick Trip Thermal Overload Relay: MSOD-T12FSKP to T100FSKP, MSOD-T21FS to T100FS
- Models with Delayed Trip Thermal Overload Relay: MSOD-T12SR to T100SR, MSOD-T21KPSR to T100KPSR, MSOD-N125SR to N400SR, MSOD-N125KPSR to N400KPSR

Note 6. Refer to page 51 for information regarding application to resistive loads and capacitive loads.

Note 7. The main contact minimum operating Voltage and current differ depending on the allowable fault rate. Refer to page 42 for details.

Note 8. MSOD-T80CW heater designation 67A is not manufactured.

Note 9. MSOD-T□ and MSOD-N□ types can also be manufactured.

Note 10. SD-T12 and SD-T20 with spring clamp terminals (SQ) can also be manufactured.

● Handling

(1) T65 to T100 type and N125 to N800 type coils of DC100V or more cannot be switched by the auxiliary contacts of thermal overload relays (TH- □ types). Switch using the contactor relay (SR or SRD type) contacts as per the figure below.

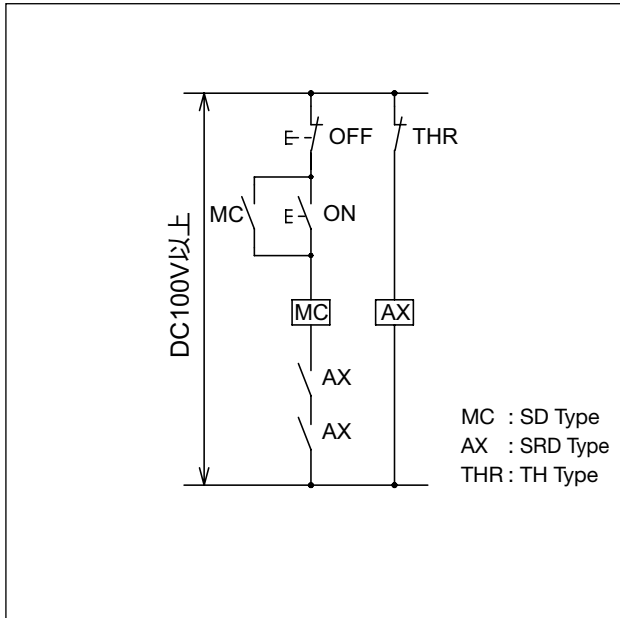

(2) Connecting differing DC operated magnetic contactor control circuits in parallel and simultaneously switching OFF can cause flip-flopping. As such, use one of the circuits listed below.

(MC1: Small Frame, MC2: Large Frame)

Circuit Example 1

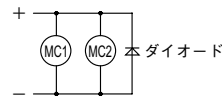

Effect of Changing Circuit

- It is necessary to restrict the polarity of the control circuit power supply.
- The open time of MC2 increases.

Circuit Example 2

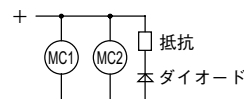

- It is necessary to restrict the polarity of the control circuit power supply.
- The open time of MC2 increases.

Circuit Example 3

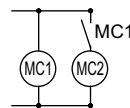

- The time until MC2 is activated increases.

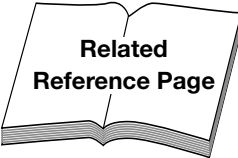
|  | Item | Reference Page | Remarks |
|---|-----------------------|----------------|---------|
| | · Main Contact Rating | Page 39 | — |
| · Auxiliary Contact Rating | Page 41 | — | |
| · Operation Coil | Page 44 | — | |
| · Properties | Page 45 | — | |
| · Performance | Page 46 | — | |
| · Outline Drawings/Contact Arrangements | Page 93 | — | |
| · How to Order | Page 130 | — | |
| · Combining with Optional Units | Page 194 | — | |

● Outline Drawings/Contact Arrangements (DC Operated Magnetic Starters/Magnetic Contactors)
 ■ T12/T20 (The diagrams show models without "BC".)

Non-Reversing

SD-T12(BC)
SD-T20(BC)

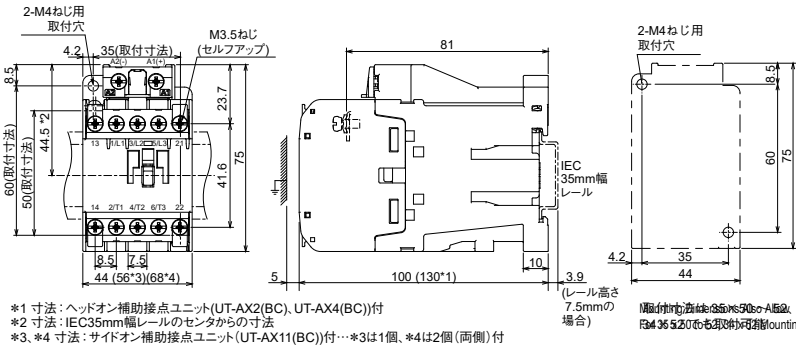
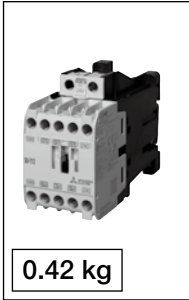

| Auxiliary Contact | Contact Arrangement | | | | | | |
|--|---------------------|------------|------------|--------|----------|--------|----------|
| 1a1b | | | | | | | |
| 2a | | | | | | | |
| <table border="1"> <thead> <tr> <th>Model Name</th> <th>Model Name</th> </tr> </thead> <tbody> <tr> <td>SD-T12</td> <td>SD-T12BC</td> </tr> <tr> <td>SD-T20</td> <td>SD-T20BC</td> </tr> </tbody> </table> | | Model Name | Model Name | SD-T12 | SD-T12BC | SD-T20 | SD-T20BC |
| Model Name | Model Name | | | | | | |
| SD-T12 | SD-T12BC | | | | | | |
| SD-T20 | SD-T20BC | | | | | | |

Reversing

SD-2 × T12(BC)
SD-2 × T20(BC)

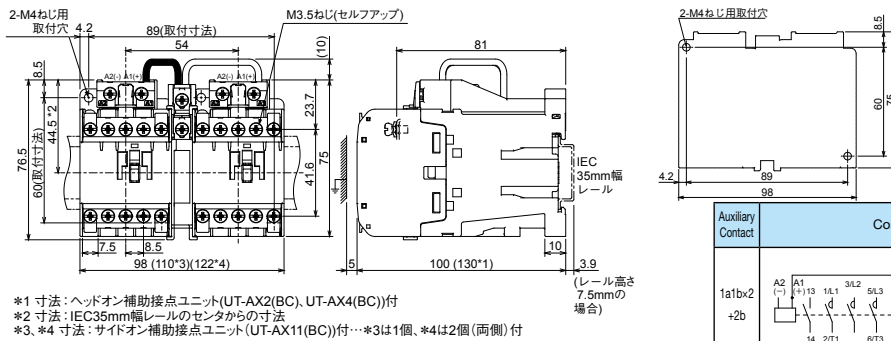
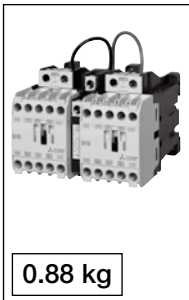

| Auxiliary Contact | Contact Arrangement | | | | | | |
|--|---------------------|------------|------------|----------|------------|----------|------------|
| 1a1b +2b | | | | | | | |
| <table border="1"> <thead> <tr> <th>Model Name</th> <th>Model Name</th> </tr> </thead> <tbody> <tr> <td>SD-2xT12</td> <td>SD-2xT12BC</td> </tr> <tr> <td>SD-2xT20</td> <td>SD-2xT20BC</td> </tr> </tbody> </table> | | Model Name | Model Name | SD-2xT12 | SD-2xT12BC | SD-2xT20 | SD-2xT20BC |
| Model Name | Model Name | | | | | | |
| SD-2xT12 | SD-2xT12BC | | | | | | |
| SD-2xT20 | SD-2xT20BC | | | | | | |

Non-Reversing

MSOD-T12(BC)KP
MSOD-T20(BC)KP

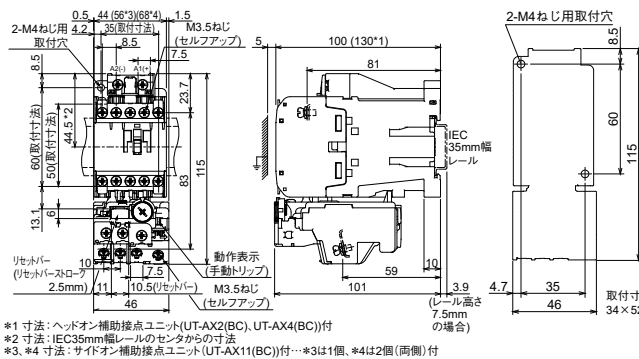
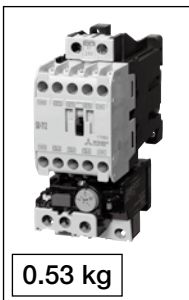

Mounting Dimensions Also Allow
For 35 x 50 to 52, 34 x 52 Mounting

| Auxiliary Contact | Contact Arrangement | | | | | | |
|--|---------------------|------------|------------|------------|--------------|------------|--------------|
| 1a1b | | | | | | | |
| 2a | | | | | | | |
| <table border="1"> <thead> <tr> <th>Model Name</th> <th>Model Name</th> </tr> </thead> <tbody> <tr> <td>MSOD-T12KP</td> <td>MSOD-T12BCKP</td> </tr> <tr> <td>MSOD-T20KP</td> <td>MSOD-T20BCKP</td> </tr> </tbody> </table> | | Model Name | Model Name | MSOD-T12KP | MSOD-T12BCKP | MSOD-T20KP | MSOD-T20BCKP |
| Model Name | Model Name | | | | | | |
| MSOD-T12KP | MSOD-T12BCKP | | | | | | |
| MSOD-T20KP | MSOD-T20BCKP | | | | | | |

Reversing

MSOD-2 × T12(BC)KP
MSOD-2 × T20(BC)KP

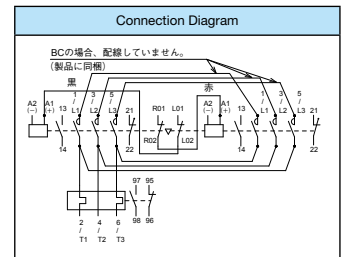
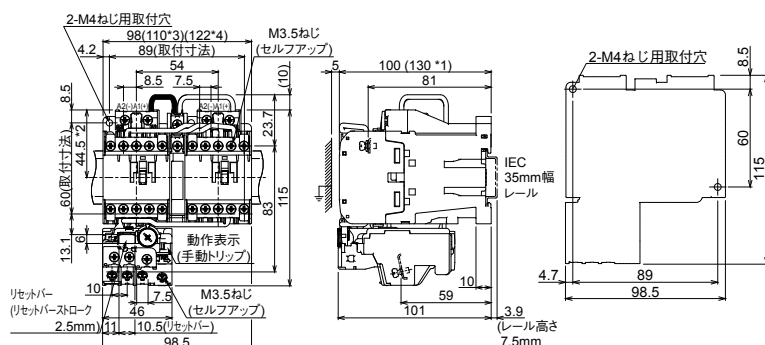
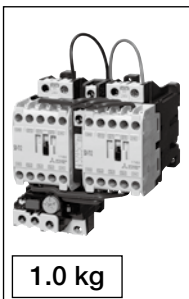

| Model Name | Model Name |
|--------------|----------------|
| MSOD-2xT12KP | MSOD-2xT12BCKP |
| MSOD-2xT20KP | MSOD-2xT20BCKP |

T32 (The diagrams show models without "BC".)

Non-Reversing

SD-T32(BC)

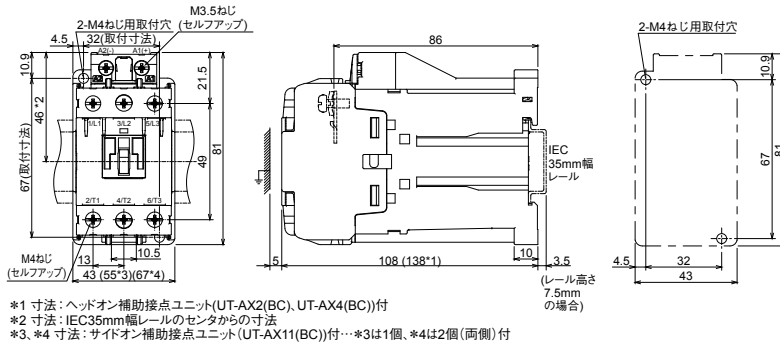
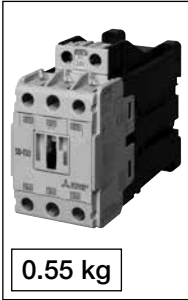

- *1 寸法：ヘッドオン補助接点ユニット(UT-AX2(BC), UT-AX4(BC))付
- *2 寸法：IEC35mm幅レールのセンターからの寸法
- *3, *4 寸法：サイドオン補助接点ユニット(UT-AX11(BC))付... *3は1個、*4は2個(両側)付

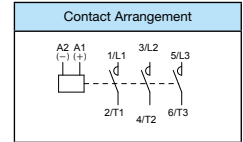

| |
|-------------------|
| Model Name |
| SD-T32 |
| SD-T32BC |

Reversing

SD-2 × T32(BC)

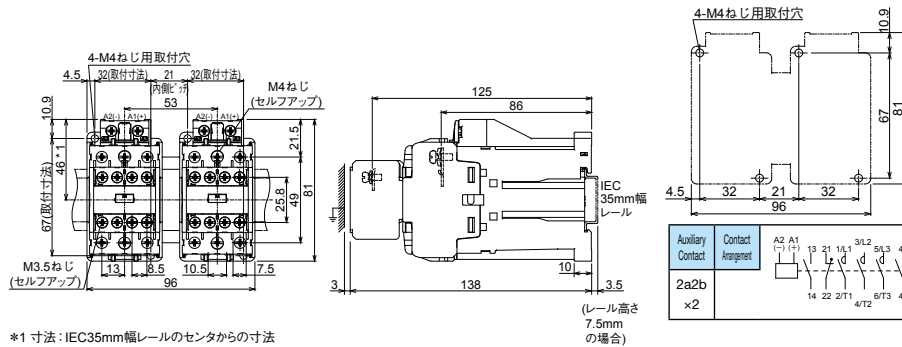

- *1 寸法：IEC35mm幅レールのセンターからの寸法

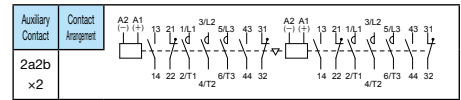

| |
|-------------------|
| Model Name |
| SD-2xT32 |
| SD-2xT32BC |

T35/T50 (The diagrams show models without "BC".)

Non-Reversing

SD-T35(BC)
SD-T50(BC)

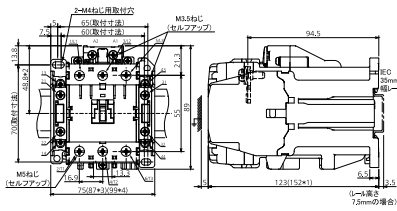
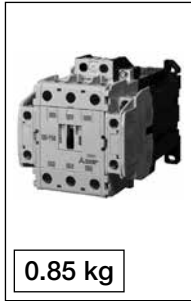

- *1寸法：ヘッドオン補助接点ユニット (UT-AX2(BC)、UT-AX4(BC)) 付
- *2寸法：IEC35mm幅レールのセンターからの寸法
- *3、*4寸法：サイドオン補助接点ユニット (UT-AX11(BC)) 付
- *3は1個、*4は2個 (両側) 付

取付寸法は60×70でも取付可能

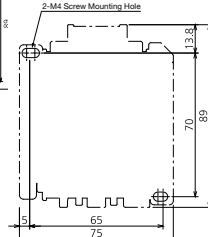

Mounting Dimensions Also Allow For 60 x 70 Mounting

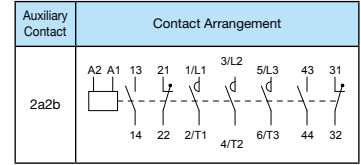

| Model Name | Model Name |
|------------|------------|
| SD-T35 | SD-T35BC |
| SD-T50 | SD-T50BC |

Reversing

SD-2 x T35(BC)
SD-2 x T50(BC)

1.96 kg

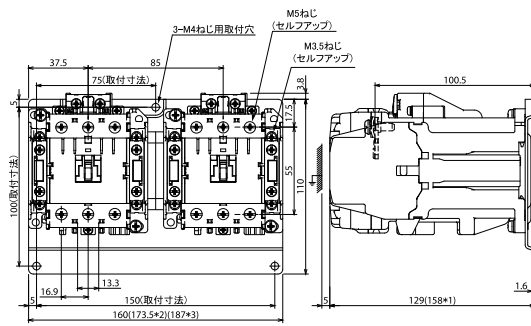

- *1寸法：ヘッドオン補助接点ユニット (UT-AX2(BC)、UT-AX4(BC)) 付
- *2、*3寸法：サイドオン補助接点ユニット (UT-AX11(BC)) 付
- *2は1個、*3は2個 (両側) 付

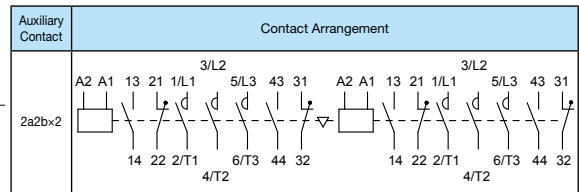
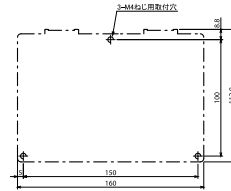

| Model Name | Model Name |
|------------|------------|
| SD-2xT35 | SD-2xT35BC |
| SD-2xT50 | SD-2xT50BC |

Non-Reversing

MSOD-T35(BC)KP
MSOD-T50(BC)KP

1.09 kg

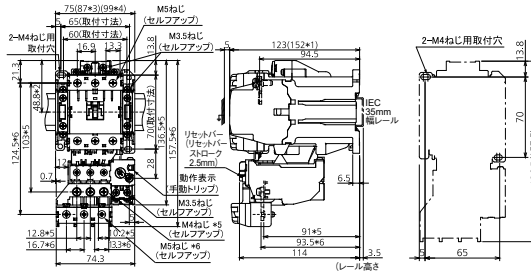

- *1寸法：ヘッドオン補助接点ユニット (UT-AX2(BC)、UT-AX4(BC)) 付
- *2寸法：IEC35mm幅レールのセンターからの寸法
- *3、*4寸法：サイドオン補助接点ユニット (UT-AX11(BC)) 付
- *3は1個、*4は2個 (両側) 付
- *5寸法：ヒータ呼び22A以下、*6寸法：ヒータ呼び29A以上

取付寸法は60×70でも取付可能

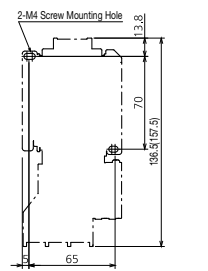

Mounting Dimensions Also Allow For 60 x 70 Mounting

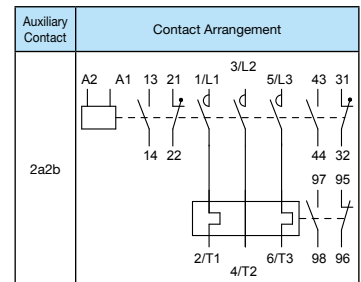

| Model Name | Model Name |
|------------|--------------|
| MSOD-T35KP | MSOD-T35BCKP |
| MSOD-T50KP | MSOD-T50BCKP |

Reversing

MSOD-2 x T35(BC)KP
MSOD-2 x T50(BC)KP

2.2 kg

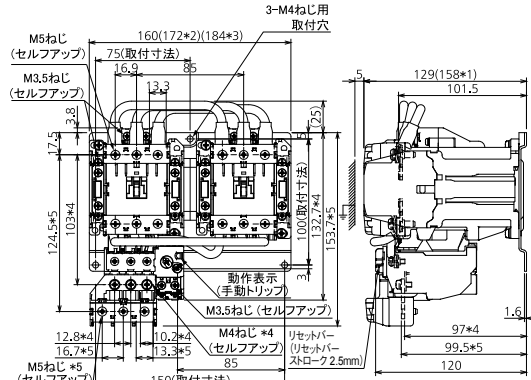

- *1寸法：ヘッドオン補助接点ユニット (UT-AX2(BC)、UT-AX4(BC)) 付
- *2、*3寸法：サイドオン補助接点ユニット (UT-AX11(BC)) 付
- *2は1個、*3は2個 (両側) 付

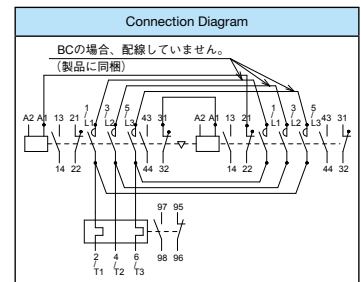
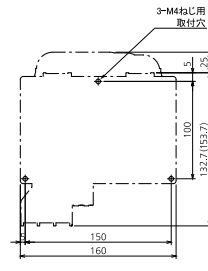

| Model Name | Model Name |
|--------------|----------------|
| MSOD-2xT35KP | MSOD-2xT35BCKP |
| MSOD-2xT50KP | MSOD-2xT50BCKP |

T65/T80 (The diagrams show models without "CW".)

Non-Reversing

SD-T65(CW)
SD-T80(CW)



2.1 kg

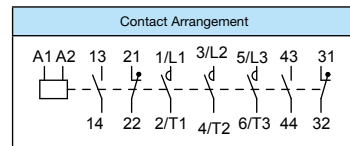
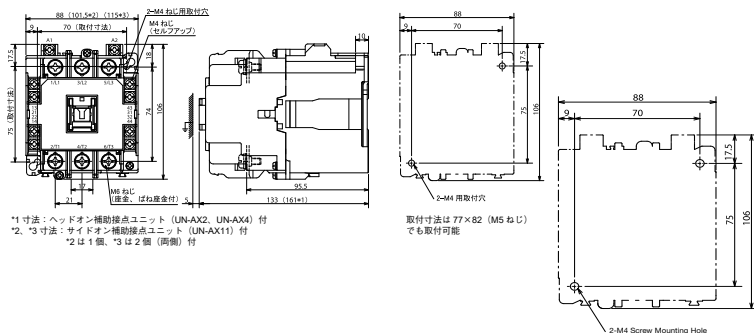

Mounting Dimensions Also Allow For 77 x 82 (M5 Screw) Mounting

| Model Name |
|------------|
| SD-T65 |
| SD-T80 |

4

Reversing

SD-2 x T65(CW)
SD-2 x T80(CW)

4.6 kg

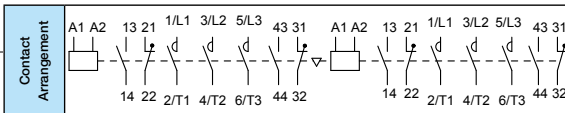
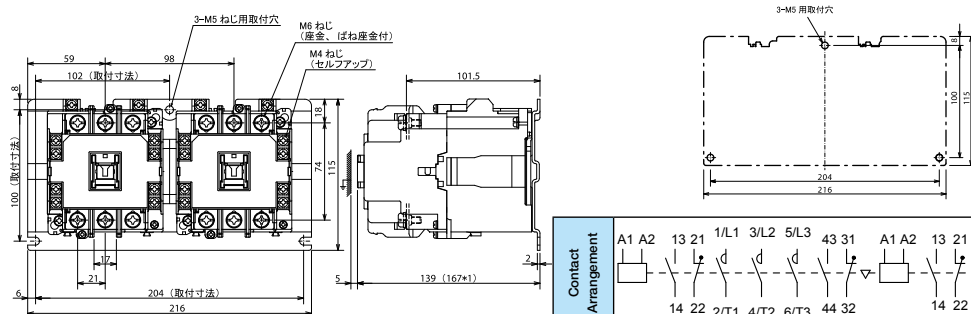

| Model Name |
|------------|
| SD-2xT65 |
| SD-2xT80 |

Non-Reversing

MSOD-T65(CW)KP
MSOD-T80(CW)KP

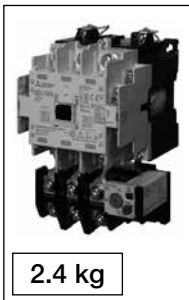

2.4 kg

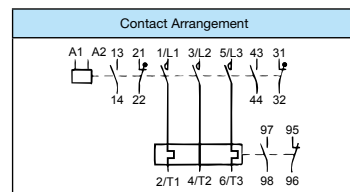
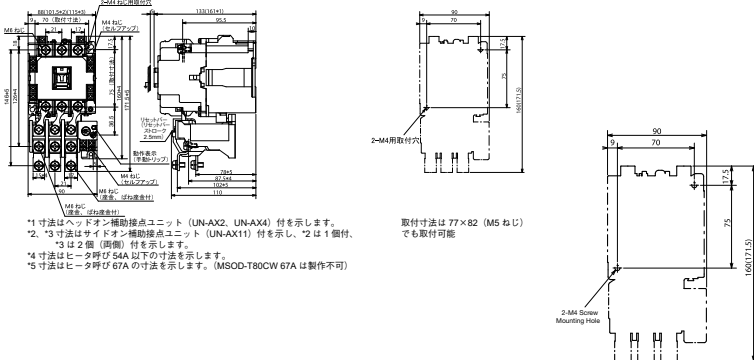

Mounting Dimensions Also Allow For 77 x 82 (M5 Screw) Mounting

| Model Name |
|------------|
| MSOD-T65KP |
| MSOD-T80KP |

Reversing

MSOD-2 x T65(CW)KP
MSOD-2 x T80(CW)KP

4.9 kg

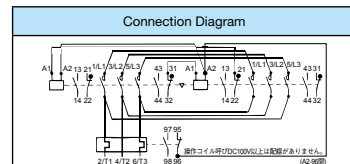
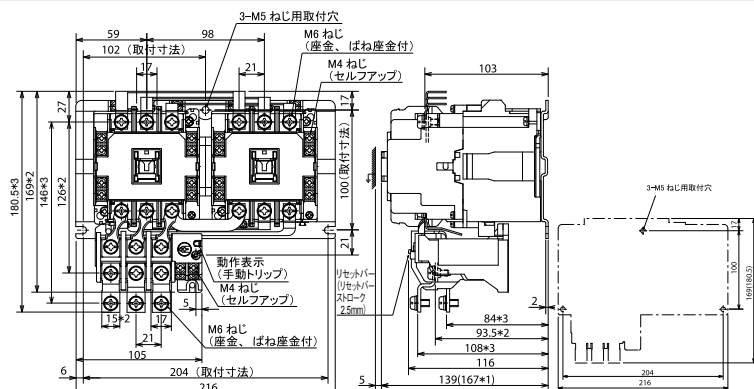

| Model Name |
|--------------|
| MSOD-2xT65KP |
| MSOD-2xT80KP |

T100

Non-Reversing

SD-T100



3.0 kg

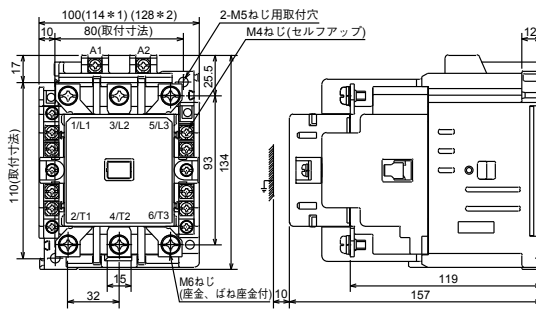

*1、*2寸法：サイドオン補助接点ユニット(UN-AX80)付・・・*1は1個、*2は2個(両側)付

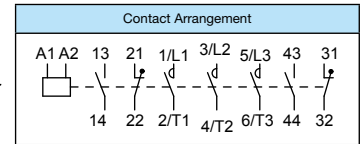
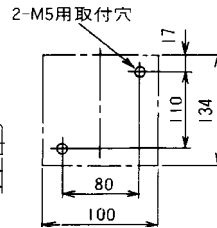

Model Name
SD-T100

Reversing

SD-2xT100

6.9 kg

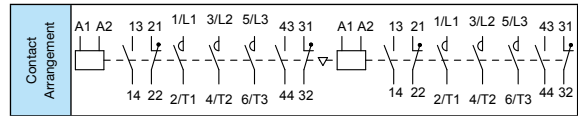
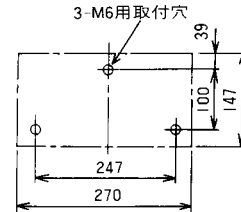
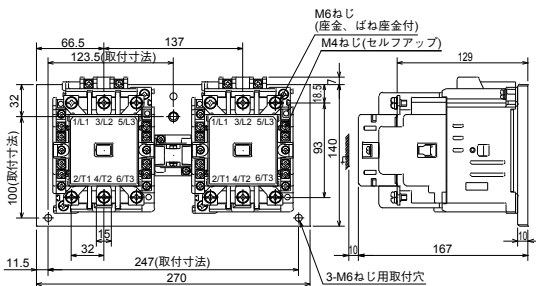

Model Name
SD-2xT100

Non-Reversing

MSOD-T100

3.5 kg

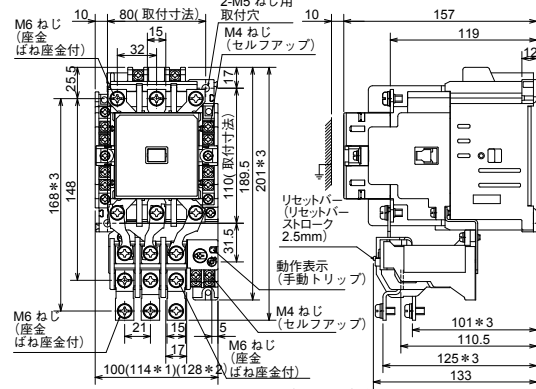

*1、*2寸法はサイドオン補助接点ユニット(UN-AX80)付を示し、
*1は1個付、*2は2個両側付を示します。
*3はヒータ呼び67A,82Aの場合を示します。

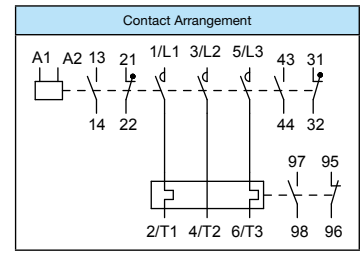
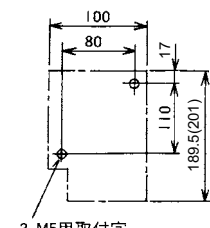

Model Name
MSOD-T100KP

Reversing

MSOD-2xT100

7.2 kg

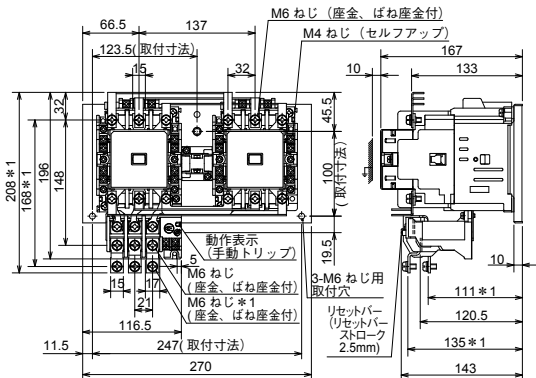

*1はヒータ呼び67A、82Aの場合を示します。

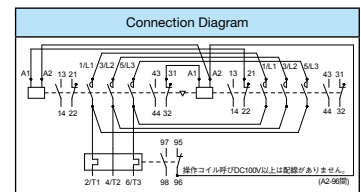
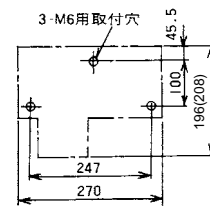

Model Name
MSOD-2xT100KP

- Outline Drawings/Contact Arrangements (Mechanically Latched Magnetic Starters/Magnetic Contactors)
- T21 (The diagrams show models without "BC".)

Non-Reversing

SL(D)-T21(BC)

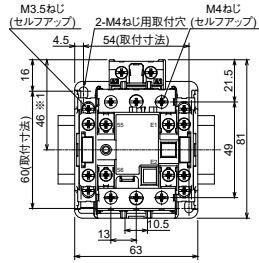
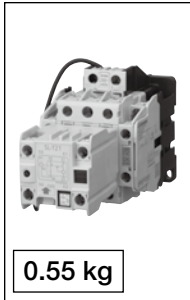

※1寸法：IEC35mm幅レールのセンタからの寸法

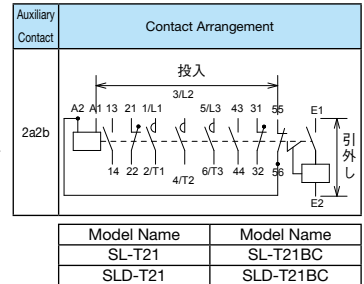
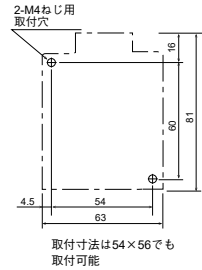

Reversing

SL(D)-2 x T21(BC)

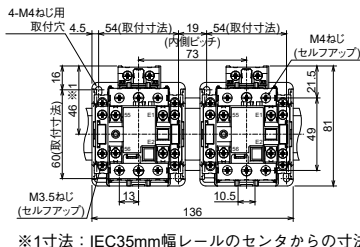

※1寸法：IEC35mm幅レールのセンタからの寸法

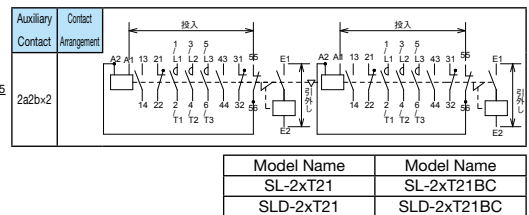
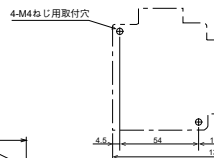

1.15 kg

T35/T50 (The diagrams show models without "BC".)

Non-Reversing

SL(D)-T35(BC)
SL(D)-T50(BC)

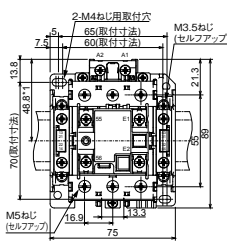
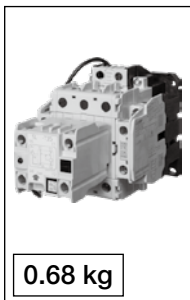

*1 Dimension: Width Dimension from Center of IEC 35 mm Rail

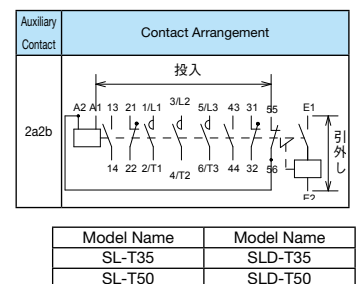
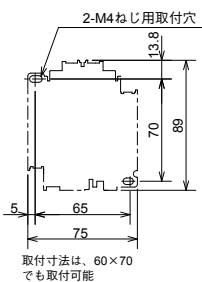

Reversing

SL(D)-2 x T35(BC)
SL(D)-2 x T50(BC)

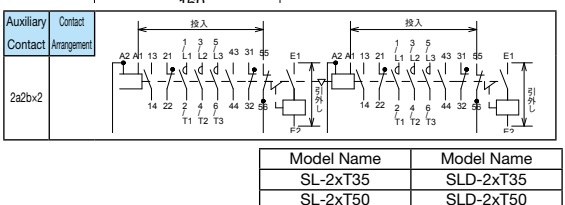
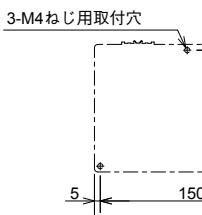
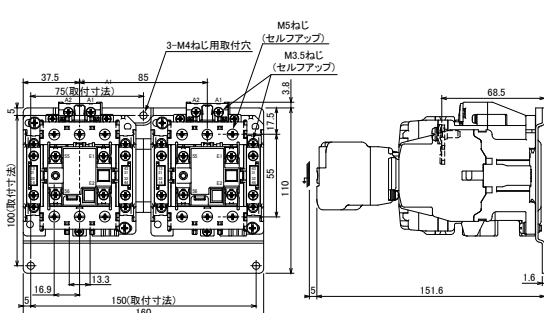

1.9 kg

4.5 MSO/S-□DL Delay Open Magnetic Starters/Magnetic Contactors

Retains the closed state for 2^{+2}_{-1} seconds during a momentary power failure

- In cases of momentary power failures or momentary voltage drops due to lightning strikes on wiring etc., the discharge from a capacitor allows the closed state to be retained for 2^{+2}_{-1} seconds.
- No re-closing operations for magnetic contactors are required when power is restored, which makes continuous load operation possible.
- Suitable for temporary storage circuitry in illumination equipment or automatic control devices.

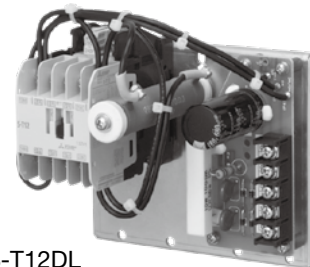

S-T12DL

● Ratings/Specifications (Standard Applicability)

| Magnetic Contactors | Magnetic Starters (Note 8) | Rated Capacity [kW] | | | | Rated Operating Current [A] | | | | Conventional Free Air Thermal Current Ith [A] | Auxiliary Contact | | Compatible Thermal Overload Relays | | | |
|---------------------|----------------------------|---|--------------|-----------|-------|---|--------------|-----------|-------|---|--------------------------------|--------------|------------------------------------|--------------------------------------|-------------------|------------------------------|
| | | Three-Phase Squirrel-cage Motor (Category AC-3) | | | | Three-Phase Squirrel-cage Motor (Category AC-3) | | | | | Resistive Load (Category AC-1) | | Valid | Additional Unit Model Names x Pieces | Model Name | Heater Designation Range [A] |
| | | 220 to 240 V | 380 to 440 V | 500 V | 690 V | 220 to 240 V | 380 to 440 V | 500 V | 690 V | | 200 to 240 V | 380 to 440 V | | | | |
| S-T12DL | MSO-T12DLKP | 3.5 [2.7] | 5.5 [4] | 5.5 [5.5] | 5.5 | 13 [13] | 12 [9] | 9 [9] | 7 | 20 | 13 | 20 | — | — Note 3 | TH-T18KP | 0.12 to 11 |
| S-T21DL | MSO-T21DLKP | 5.5 [4] | 11 [7.5] | 11 [7.5] | 7.5 | 25 [20] | 23 [20] | 17 [17] | 9 | 32 | 32 | 32 | 1a1b | | TH-T25KP | 0.24 to 22 |
| S-T35DL | MSO-T35DLKP | 11 [7.5] | 18.5 [15] | 18.5 [15] | 15 | 40 [35] | 40 [32] | 32 [26] | 17 | 60 | 60 | 60 | 1a1b | | TH-T25KP | 0.24 to 22 |
| S-T50DL | MSO-T50DLKP | 15 [11] | 22 [22] | 25 [22] | 22 | 55 [50] [50] (Note 1) | 50 [48] | 38 [38] | 26 | 80 | 80 | 80 | | | TH-T50KP | 29 |
| S-T65DL | MSO-T65DLKP | 18.5 [15] | 30 [30] | 37 [30] | 30 | 65 [65] | 65 [65] | 60 [45] | 38 | 100 | 100 | 100 | | | TH-T25KP | 0.24 to 22 |
| S-T80DL | MSO-T80DLKP | 22 [19] | 45 [37] | 45 [45] | 45 | 85 [80] | 85 [80] | 75 [75] | 52 | 120 | 120 | 120 | | | TH-T50KP | 29 to 42 |
| S-T100DL | MSO-T100DLKP | 30 [22] | 55 [45] | 55 [45] | 55 | 105 [100] | 105 [93] | 85 [75] | 65 | 150 | 150 | 150 | 1a1b | | TH-T65KP | 15 to 54 |
| S-T100DL | MSO-T100DLKP | 30 [22] | 55 [45] | 55 [45] | 55 | 105 [100] | 105 [93] | 85 [75] | 65 | 150 | 150 | 150 | | | TH-T65KP (Note 8) | 67 |
| S-N150DL | MSO-N150DLKP | 45 [37] | 75 [75] | 90 [90] | 90 | 150 [150] | 150 [150] | 140 [140] | 100 | 200 | 200 | 200 | 1a1b | | TH-T100KP | 15 to 54 |
| S-N220DL | MSO-N220DLKP | 75 [55] | 132 [110] | 132 [132] | 132 | 250 [220] | 250 [220] | 200 [200] | 150 | 260 | 260 | 260 | | | TH-N120KP(TA) | 42 to 125 |
| S-N300DL | MSO-N300DLKP | 90 [75] | 160 [150] | 160 [160] | 200 | 300 [300] | 300 [300] | 250 [250] | 220 | 350 | 350 | 350 | | TH-N220KPRH | 82 to 180 | |
| S-N400DL | MSO-N400DLKP | 125 [110] | 220 [200] | 225 [200] | 250 | 400 [400] | 400 [400] | 350 [350] | 300 | 450 | 450 | 450 | | TH-N400KPRH | 105 to 250 | |
| S-N400DL | MSO-N400DLKP | 125 [110] | 220 [200] | 225 [200] | 250 | 400 [400] | 400 [400] | 350 [350] | 300 | 450 | 450 | 450 | | | 105 to 330 | |

Note 1. The value in parentheses for the rated operating current is applicable in the case of magnetic contactors.

Note 2. The combining magnetic contactor is dedicated for use with T50 or less AC operated type (S type), or T65 to 100 and N125 or greater DC operated type (SD type), and cannot be replaced alone.

Note 3. Auxiliary contact units UN-AX150 can be installed on the left side for N150DL to N400DL types; however, T12DL to T100DL types cannot be used to mount additional auxiliary contact units.

Note 4. Magnetic starters can be manufactured to have 3-element (2E) thermal overload relays (MSO- □ DLKP) included.

Note 5. MSO-T12 to T100DL(KP)SR (with saturable reactors and thermal overload relays) cannot be manufactured.

Note 6. Instantaneous stop/restart relays (JA-DL2) are also available as related products. Refer to page 346.

Note 7. Cannot be used with live part protection covers. Furthermore, types with wiring streamlining terminals (BC) cannot be manufactured.

Note 8. Thermal overload relay dedicated for MSO-T80DL 67 A. S-T80DL and the standard TH-T100 67A cannot be combined for use as a magnetic starter.

Note 9. MSO-T□DL and MSO-N□DL types can also be manufactured.

● Properties/Performance/Operation Coil

| Frame | Input [VA] | | Operating Voltage [V] | | Operating Time [ms] | | Operation Coils | | Making and Breaking Current Capacities | Switching Frequency | Switching Durability [x 10000] | | Delay Time | |
|--------|------------|--------|---|---|-------------------------------------|---------------------------------------|-----------------|-------------------------|---|---------------------|--|----------------------------|-------------------------------|-----|
| | Inrush | Normal | Close | Open | Operating Power ON →Main Contact ON | Operating Power OFF →Main Contact OFF | Designation | Rated Voltage | | | Mechanical | Electrical (Category AC-3) | | |
| T12DL | 70 | 13 | 85% or Less of Operation Coil Rated Voltage | 10% or More of Operation Coil Rated Voltage | 7 to 100 | | AC100V | 100 to 110V 50/60 Hz | 10 Times Class AC-3 Rated Operating Current | 1200 Times/ Hour | 100 | 100 | 2^{+2}_{-1} Seconds (Fixed) | |
| T21DL | 100 | 15 | | | 7 to 100 | | | | | | | | | |
| T35DL | 113 | 24 | | | 7 to 100 | | | | | | | | | |
| T50DL | 113 | 24 | | | 7 to 100 | | | | | | | | | |
| T65DL | 55 | 26 | | | 7 to 100 | | | | | | | | | |
| T80DL | 55 | 26 | | | 7 to 100 | | | | | | | | | |
| T100DL | 66 | 27 | | | 7 to 100 | | AC200V | 200 to 220V 50/60 Hz | | | 8 Times Class AC-3 Rated Operating Current | | | 500 |
| N150DL | 76 | 55 | | | 30 to 100 | | | | | | | | | |
| N220DL | 100 | 66 | | | 30 to 100 | | | | | | | | | |
| N300DL | 140 | 85 | 30 to 100 | | | | | | | | | | | |
| N400DL | 140 | 85 | 30 to 100 | | | | | | 50 | | | | | |

Note 1. The above indicates rough property indices for AC200V coils.

Note 2. The input is the average when applying 220 V at 60 Hz. Values for AC100V coils are approximately the same.

Note 3. The operating time is the value when applying 200 V at 60 Hz. Values for AC100V coils are approximately the same.

Note 4. Operation coils are only AC100V or AC200V.

Connecting

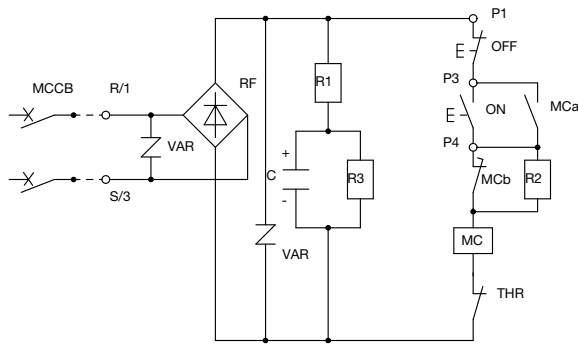

Deployment Connection Diagram

Note 1. The figure to the left is for MSO-□DL.

Note 2. The MCCB, ON and OFF buttons in the figure to the left are not provided.

Note 3. If connecting an external magnetic coil or indicator lamp, connect between the R/1 and S/3 terminals.

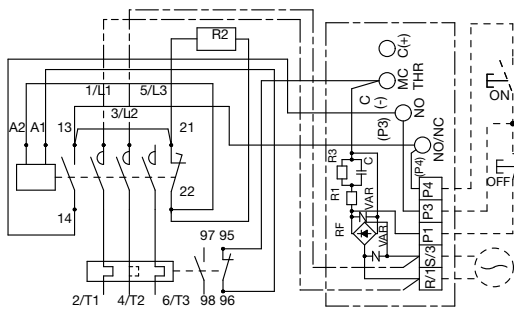

MSO-T12DL(KP) Actual Wiring Diagram

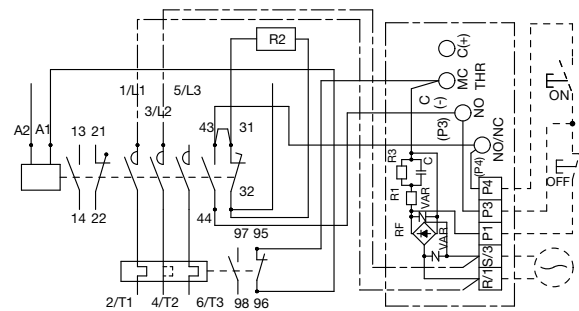

MSO-T21DL(KP) Actual Wiring Diagram

The connections shown with single-dashed lines between the L1-R/1 and L2-S/3 terminals are not wired if the control circuit voltage is AC100 V or if the main circuit and control circuit voltages differ.

Operation Description (Deployment Connection Diagram)

Power Supply Closing

Closing the power supply with **MCCB** causes **C** to charge via **RF** and **R1**.

Closing Magnetic Contactors

Pressing the **ON** button causes **MC** to energize via **MCb**, closing the contactor.

When **MC** has completed closing, **MCb** opens and, in the order of **MCa** → **R2** → **MC**, the current flows to retain the contactor.

Opening Magnetic Contactors

Pressing the **OFF** button cuts off current to **MC**, instantly opening the magnetic contactor.

When Power Supply Voltage Drops and Momentary Power Failures Occur

Charge accumulated in **C** discharges via **R1** → **R2** → **MC** circuits, opening **MC** after a predetermined time (after the delay time).

Handling (Deployment Connection Diagram)

- If ON and OFF for **MCCB** are repeated at short intervals (or when momentary power failures occur several times in quick succession) the following may occur
 - (1) The inrush current to **RF** and **R1** repeatedly flows, causing overloading.
 - (2) Sufficient charge is not provided to **C**, causing damage to components or insufficient retention time.
- Even when the power is OFF (**MCCB** is OFF), charge may still reside within **C**, so necessary precautions should be taken to avoid electric shocks.
- ON and OFF operations should be conducted using the push-button switch located as in the figure above. The magnetic contactor may flip-flop when the power is switched ON or OFF. Also, when switching the power to perform sequence checks etc., the operator should allow at least 5 seconds for the capacitor to charge.
- Uses an electrolytic capacitor so the delay time should be checked periodically.

● Outline Drawings

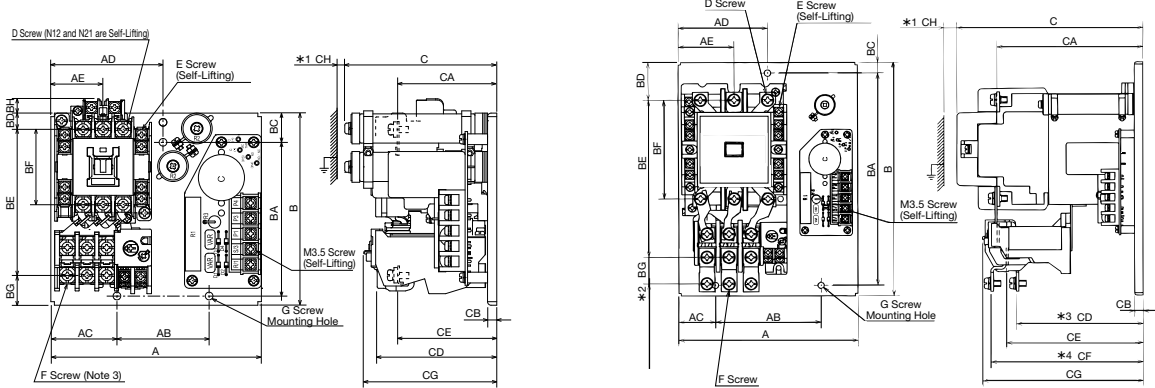

MSO/S-T12, T21, T35, T50DL

MSO/S-T65 to T100DL
MSO/S-N125 to N400DL

◆Caution Do not install wiring or other equipment in the vicinity of the resistor (refer to the figure above) as it reaches high temperatures (approx. 100°C temperature rise).

Variable Dimensions Table

| Variable Dimensions | A | AB | AC | AD | AE | B | BA | BC | BD | BE | BF | BG | BH | C | CA | CB | CD | CE | CF | CG | CH | D | E | F | G |
|---------------------|-----|-----|----|-----|------|-------|-----|----|------|-------|------|------|------|-------|-------|----|------|-------|-----|-------|----|------|------|----|------|
| Frame | | | | | | | | | | | | | | | | | | | | | | | | | |
| T12DL | 132 | 40 | 49 | 69 | 29.8 | 110 | 100 | 5 | 11.2 | 83 | 41.6 | — | 12.5 | 113 | 65 | 6 | — | 43 | — | 85 | 5 | M3.5 | M3.5 | — | 3-M4 |
| T21DL | 137 | 60 | 43 | 73 | 34 | 125 | 100 | 19 | 10.5 | 94.5 | 49 | — | 11 | 113 | 65 | 6 | — | 65 | — | 88 | 5 | M4 | M3.5 | — | 3-M4 |
| T35/T50DL | 134 | 50 | 42 | 67 | 38.5 | 162 | 150 | 6 | 23 | 103 | 55 | 21.5 | — | 114 | 70.5 | 8 | 69.5 | 67 | — | 89 | 5 | M5 | M3.5 | M5 | 3-M4 |
| T65/T80DL | 150 | 50 | 56 | 81 | 50 | 168 | 150 | 9 | 27 | 126 | 74 | — | — | 141 | 103.5 | 8 | — | 95.5 | — | 118 | 5 | M6 | M4 | M6 | 3-M5 |
| T100DL | 170 | 100 | 35 | 85 | 53 | 220 | 200 | 10 | 35.5 | 148 | 93 | 20 | — | 165 | 127 | 8 | 109 | 118.5 | 133 | 141 | 10 | M6 | M4 | M6 | 3-M6 |
| N150DL | 210 | 140 | 26 | 105 | 80 | 270 | 250 | 10 | 33 | 200 | 130 | 25 | — | 177.5 | 136.5 | 8 | — | 99.5 | 102 | 133.5 | 10 | M8 | M4 | M8 | 3-M8 |
| N220DL | 230 | 140 | 20 | 90 | 90 | 290 | 250 | 12 | 31 | 246.5 | 158 | — | — | 208.5 | 156.5 | 8 | — | 103.5 | — | 214 | 10 | M10 | M4 | — | 3-M8 |
| N300/N400DL | 300 | 200 | 10 | — | 110 | 363.5 | 200 | 25 | 30 | 318.5 | 190 | — | — | 229 | 170 | 8 | — | 122.5 | — | 227 | 10 | M12 | M4 | — | 4-M8 |

Weight Table

| | S- | MSO- |
|-------------|---------|---------|
| T12DL | 0.73 | 0.84 |
| T21DL | 0.98 | 1.2 |
| T35/T50DL | 1.20 | 1.44 |
| T65/T80DL | 2.8 | 3.1 |
| T100DL | 3.9 | 4.4 |
| N150DL | 6.3 | 7.6 |
| N220DL | 9.1 | 11.6 |
| N300/N400DL | 15/15.5 | 17.5/18 |

- Note 1. *1: "CH" is the arc space.
 Note 2. Below indicates the case when using TH-T50/T100 and TH-N□TA thermal overload relays.
 *2: "BG" has extended terminal pitch, "F Screw" has a terminal screw on the load side
 *3: "CD" has load side 4/T2 terminal height
 *4: "CF" has load side 2/T1, 6/T3 terminal height
 Note 3. The F screw for MSO-T35/T50DL is M4 with heater designations of 22A or below.
 Note 4. The maximum outline drawings (A x B x C) of S-□DL and MSO-□DL are the same. However, S-N300/N400DL has a "B" dimension of 250.
 Note 5. The power connector protrudes from the product on the power supply side by approximately 15 mm.

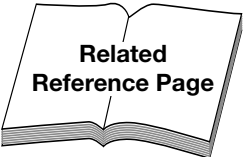
| | Item | Reference Page | Remarks |
|---|---------------------------------|----------------|--|
|  | · Main Contact Rating | Page 39 | — |
| | · Auxiliary Contact Rating | Page 41 | — |
| | · How to Order | Page 133 | Be sure to specify main circuit specifications and operation coil designation as both MSO-□DL and S-□DL may or may not require wiring from the main circuit. |
| | · Combining with Optional Units | Page 194 | — |

Outline Drawings/Contact Arrangements

S-T12SQ
S-T20SQ

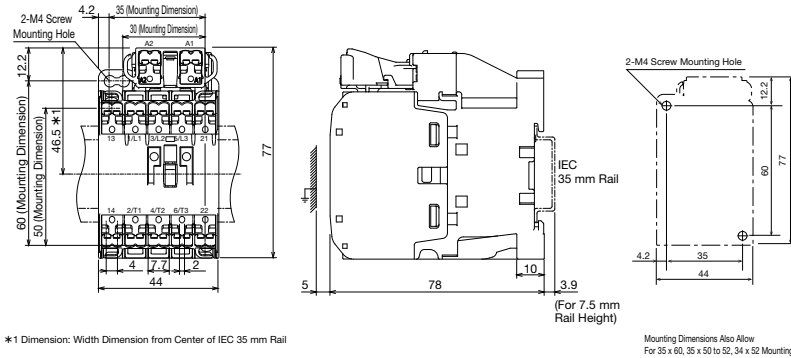

| Auxiliary Contact | Contact Arrangement |
|-------------------|---------------------|
| 1a1b | |
| 2a | |

| Model Name |
|------------|
| S-T12SQ |
| S-T20SQ |

SD-T12SQ
SD-T20SQ

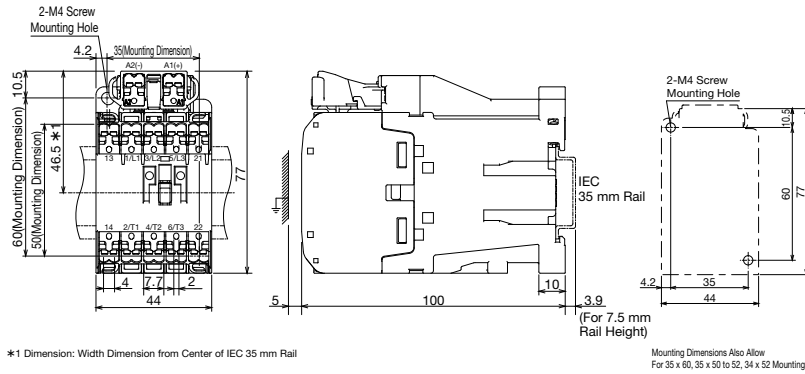
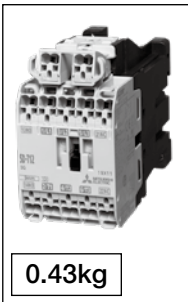

| Auxiliary Contact | Contact Arrangement |
|-------------------|---------------------|
| 1a1b | |
| 2a | |

| Model Name |
|------------|
| SD-T12SQ |
| SD-T20SQ |

4.11 S(D)-T32, S-N□8 Main Circuit 3-Pole Magnetic Contactors

Dramatically reduces panel installation area required

- A space-saving type without auxiliary contacts equipped and just 3-pole main contacts.
- If auxiliary contacts are required, auxiliary contact units can be installed. (Reversing types have 2a2b x 2 installed)



S-T32

S-N48

● Ratings/Specifications (Standard Applicability)

| Magnetic Contactors | | Rated Capacity [kW] | | | | Rated Operating Current [A] | | | | Conventional Free Air Thermal Current [A] | Additional Auxiliary Contact Unit Model Name x Pieces (Note 2) | Terminal Screw Size (Standard Tightening Torque N·m) | | Recommended Crimp Lug Size Compatible with Terminal | | | |
|-------------------------|---------------------------------|---|--------------|-------|-------|---|--------------|-------|-------|---|--|--|----------------------------------|---|-------------------------------|--------------------|----------------------|
| | | Three-Phase Squirrel-cage Motor (Category AC-3) | | | | Three-Phase Squirrel-cage Motor (Category AC-3) | | | | | | Resistive Load (Category AC-1) | | Main Circuit | Control Circuit | Main Circuit | Control Circuit |
| Non-Reversing | Reversing | 220 to 240 V | 380 to 440 V | 500 V | 690 V | 220 to 240 V | 380 to 440 V | 500 V | 690 V | 200 to 220 V | 380 to 440 V | I _{th} [A] | | | | | |
| S-T32(BC) SD-T32(BC) | S-2 x T32(BC) SD-2 x T32(BC) | 7.5 | 15 | 15 | 11 | 32 | 32 | 24 | 12 | 32 | 32 | 32 | UT-AX2, 4 x 1 UT-AX11 x 2 | M4 1.18 - 1.86 (1.47) | M3.5 0.94 - 1.51 (1.17) | 1.25-4 to 5.5-4 | 1.25-3.5 to 2-3.5 |
| S-N38(CX) | S-2 x N38(CX) | 7.5 | 15 | 15 | | 35 | 32 | 24 | | 60 | 60 | 60 | UN-AX2, 4 x 1 (Front Clip-on) | M5 2.06 - 3.33 (2.55) | M3.5 0.94 - 1.51 (1.17) | 1.25-5 to 14-5 | 1.25-3.5 to 2-3.5 |
| S-N48(CX) | S-2 x N48(CX) | 11 | 15 | 15 | | 50 | 35 | 24 | | 80 | 80 | 80 | | | | | |

Note 1. The M4 main circuit terminal screw size for T32 types makes it unsuitable for applications exceeding 20 A in accordance with the Electrical Appliance and Material Safety Law.

Note 2. Reversing types already have 2 UT/UN-AX4 units installed so no more can be mounted. Furthermore, all side clip-on units (UT/UN-AX11) are not applicable.

Note 3. Types including thermal overload relays (MSO) are not manufactured.

Note 4. A "BC" in the model name indicates a wiring streamlining terminal, "CX" indicates a CAN terminal.

Note 5. Please note that SD-T32 type operation coil terminals have polarity. A1 (+), A2 (-)

● Properties/Performance

| Model Name | Input [VA] | | Power Consumption [W] | Coil Current [mA] | Operating Voltage [V] | | Operating Time [ms] | | Making Current Capacity [A] (Peak 0.5 ms) | Switching Frequency | Switching Durability [x 10000] | |
|------------|------------|---------|-----------------------|-------------------|-----------------------|-----------|--------------------------|----------------------------|---|---------------------|--------------------------------|----------------------------|
| | Momentary | Regular | | | Close | Open | Coil ON→ Main Contact ON | Coil OFF→ Main Contact OFF | | | Mechanical | Electrical (Category AC-3) |
| SD-T32 | — | — | 3.3 (2.2) | 0.033 | 60 to 75 | 10 to 30 | 70 (95) | 20 | 400 | 1800 Times/Hour | 1000 | 200 |
| S-T32 | 55 | 4.5 | 1.8 | 20 | 125 to 155 | 80 to 115 | 15 to 22 | 5 to 15 | 400 | | | |
| S-N38 | 110 | 13 | 4.3 | 80 | 120 to 145 | 90 to 115 | 10 to 20 | 5 to 14 | 500 | 1200 Times/Hour | 500 | 100 |
| S-N48 | 110 | 13 | 4.3 | 80 | 120 to 145 | 90 to 115 | 10 to 20 | 5 to 14 | 670 | | | |

Note 1. The above table indicates rough property indices for DC100V coils for DC operated types and AC200V coils for AC operated types. The values in the parentheses for SD-T32 indicate rough property indices for DC12V or DC24V coils.

Note 2. The operating voltage is that at a 20°C cold state. (AC operated type values are for 60 Hz)

Note 3. The coil current is the average regular value with DC100V (DC operated type) or AC220 V at 60 Hz (AC operated type) applied.

Note 4. The operating time is the value with DC100V (DC operated type) or AC220 V at 60 Hz (AC operated type) applied.

Note 5. The coil input and power consumption are the average values.

Note 6. The electrical durability at the making current capacity lasts 100,000 operations.

| | Item | Reference Page | Remarks |
|--|---------------------------------|----------------|---------|
| | · Main Contact Rating | Page 39 | — |
| | · Operation Coil | Page 43 | — |
| | · How to Order | Pages 131,133 | — |
| | · Combining with Optional Units | Page 194 | — |

4.12 How to Order

Precautions

Follow the steps below when ordering. Enter a space in ▲.
 If there are multiple 2 letter symbols (SA, BC, KP etc.) appended to the model name frame size (T10 etc.) then specify them in alphabetical order. (E.g.: MSO-T10BCKPSA)
 (If not in alphabetical order, the model name displayed will change automatically.)

● MS-T Series

1. Standard (AC Operated) Magnetic Starters

■ MS-(2x)T (Enclosed Type)

| Model Name | Motor Capacity | Main Circuit Voltage | Operation Coil Designation or Control Circuit Voltage/Frequency | (Note) Auxiliary Contact |
|---------------------------|-----------------------------|---|---|---|
| MS-T21KP MS-T10KP | ▲ 3.7kW | ▲ 200V ▲ 200V | ▲ AC200V ▲ AC200V | ▲ 1B |
| Refer to pages 74 and 75. | Select from page 48 or 139. | Do not apply AC voltage to the main circuit. (To distinguish it from the control circuit voltage) | Select the coil designation from page 43 or specify the control circuit voltage and frequency used. | Specify if using a special contact arrangement. Refer to page 41. |

■ MSO-(2x)T (Open Type)

| Model Name | Motor Capacity or Heater Designation (Knob Setpoint) | Main Circuit Voltage | Operation Coil Designation or Control Circuit Voltage/Frequency | (Note) Auxiliary Contact |
|---------------------------|--|---|---|---|
| MSO-T10KP | ▲ 9A | ▲ 200V | ▲ AC200V | ▲ 1B |
| Refer to pages 74 and 75. | Select from page 48 or 139. | Do not apply AC voltage to the main circuit. (To distinguish it from the control circuit voltage) | Select the coil designation from page 43 or specify the control circuit voltage and frequency used. | Specify if using a special contact arrangement. Refer to page 41. |

2. Standard (AC Operated) Magnetic Contactors

■ S-T Type, S-2xT Type

| Model Name | Operation Coil Designation or Control Circuit Voltage and Frequency | (Note) Auxiliary Contact |
|---------------------------|---|---|
| S-T20 S-T20 | ▲ AC200V ▲ AC100V50Hz | ▲ 2A |
| Refer to pages 74 and 75. | Select the coil designation from page 43 or specify the control circuit voltage and frequency used. | Specify if using a special contact arrangement. Refer to page 41. |

3. DC Operated Magnetic Starters/Contactors

■ MSOD-T Type

| Model Name | Motor Capacity or Heater Designation (Knob Setpoint) | Main Circuit Voltage | Operation Coil Designation | (Note) Auxiliary Contact |
|-------------------|--|--|---|---|
| MSOD-T21KP | ▲ 3.7kW | ▲ 200V | ▲ DC100V | ▲ |
| Refer to page 91. | Select from page 48 or 139. | Do not apply AC voltage to the main circuit. | Select the coil designation from page 44. | Specify if using a special contact arrangement. Refer to page 41. |

■ SD-T Type

| Model Name | Operation Coil Designation | (Note) Auxiliary Contact |
|--|---|---|
| SD-T21 | ▲ DC110V | ▲ |
| Refer to page 91. SD-2 x T21 is a reversing type. | Select the coil designation from page 44. | Specify if using a special contact arrangement. Refer to page 41. |

4. Mechanically Latched Magnetic Starters/Contactors

■ MSOL-T Type

| Model Name | Motor Capacity or Heater Designation (Knob Setpoint) | Main Circuit Voltage | Closing Coil | Tripping Coil |
|---|--|---|---|---------------|
| MSOL-T21KP | ▲ 3.7kW | ▲ 200V | ▲ MC-AC200V | ▲ MT-AC200V |
| Specify "MSOLD" if using a DC operated closing coil. Refer to page 102. | Select from page 48 or 139. | Do not apply AC voltage to the main circuit. (To distinguish it from the control circuit voltage) | Select the coil designation from page 44. | |

■ SL-T Type, SLD-T Type

| Model Name | Closing Coil Designation | Tripping Coil Designation |
|--|---|---------------------------|
| SL-T21 | ▲ MC-AC100V | ▲ MT-AC100V |
| Refer to page 102. · The model name is SLD if using a DC operated closing coil. | Select the coil designation from page 44. | |

■ SL-2xT Type, SLD-2xT Type

Specify using the SL-T type listed above if the left and right closing coils or tripping coils have the same ratings. However, specify using the following if the left and right coils have different ratings.

| Model Name | Closing Coil Designation (Left Side) | Tripping Coil Designation (Left Side) | Closing Coil Designation (Right Side) | Tripping Coil Designation (Right Side) |
|--|---|---------------------------------------|---------------------------------------|--|
| SL-2xT21 | ▲ MC1-AC100V | ▲ MT1-AC100V | ▲ MC2-AC100V | ▲ MT2-DC100V |
| Refer to page 102. · The model name is SLD if using a DC operated closing coil. | Select the coil designation from page 44. | | | |

5. Delay Open Magnetic Starters/Contactors

■ MSO-T□DL, S-T□DL Type

| Model Name | Main Circuit Specifications | Operation Coil |
|------------------------|---|---|
| MSO-T21DLKP S-T12DL | ▲ 15A ▲ 200V | ▲ AC200V ▲ AC200V |
| Specify from page 111. | Specify the rated voltages of the thermal overload relay heater designation and main circuit. Be sure to specify the rated voltage as there are strict criteria for the internal wiring of magnetic contactors. | The operation coil designation is available in AC100V and AC200V. |

6. Magnetic Starters with Delay Trip Thermal Overload Relays

MSO-T SR Type

| Model Name | Motor Capacity or Heater Designation (Knob Setpoint) | Main Circuit Voltage | Operation Coil Designation or Control Circuit Voltage/Frequency | (Note) Auxiliary Contact |
|------------------------|--|--|---|---|
| MSO-T12SR | 2.2kW | 200V | AC200V | |
| Specify from page 114. | Select from page 48 or 139. | Do not apply AC voltage to the main circuit. | Select the coil designation from page 43 or specify the control circuit voltage and frequency used. | Specify if using a special contact arrangement. Refer to page 41. |

7. Magnetic Starters with Quick Trip Thermal Overload Relays

MSO-T FS/FSKP Type

| Model Name | Motor Capacity or Heater Designation (Knob Setpoint) | Main Circuit Voltage | Operation Coil Designation or Control Circuit Voltage/Frequency | (Note) Auxiliary Contact |
|------------------------|--|--|---|---|
| MSO-T12FSKP | 2.2kW | 200V | AC200V | |
| Specify from page 116. | Select from page 48 or 139. | Do not apply AC voltage to the main circuit. | Select the coil designation from page 43 or specify the control circuit voltage and frequency used. | Specify if using a special contact arrangement. Refer to page 41. |

8. Magnetic Starters with Push-Buttons

MS-T KPPM Type

| Model Name | Motor Capacity | Main Circuit Voltage | Operation Coil Designation or Control Circuit Voltage/Frequency | (Note) Auxiliary Contact |
|------------------------|-----------------------------|---|---|---|
| MS-T21KPPM | 3.7kW | 200V | AC200V | |
| Specify from page 117. | Select from page 48 or 139. | Do not apply AC voltage to the main circuit. (To distinguish it from the control circuit voltage) | Select the coil designation from page 43 or specify the control circuit voltage and frequency used. | Specify if using a special contact arrangement. Refer to page 41. |

9. Magnetic Starters/Magnetic Contactors with Wiring Streamlining Terminals

MSO-T BC Type

| Model Name | Motor Capacity or Heater Designation (Knob Setpoint) | Main Circuit Voltage | Operation Coil Designation or Control Circuit Voltage/Frequency | (Note) Auxiliary Contact |
|------------------------|--|--|---|---|
| MSO-T12BCKP | 2.2kW | 200V | AC200V | |
| Specify from page 119. | Select from page 48 or 139. | Do not apply AC voltage to the main circuit. | Select the coil designation from page 43 or specify the control circuit voltage and frequency used. | Specify if using a special contact arrangement. Refer to page 41. |

S-T BC Type

| Model Name | Operation Coil Designation or Control Circuit Voltage and Frequency | (Note) Auxiliary Contact |
|------------------------|---|---|
| S-T12BC | AC200V | |
| Specify from page 119. | Select the coil designation from page 43 or specify the control circuit voltage and frequency used. | Specify if using a special contact arrangement. Refer to page 41. |

10. Magnetic Contactors with Spring Clamp Terminals

S-T SQ Type

| Model Name | Operation Coil Designation or Control Circuit Voltage and Frequency |
|------------------------|---|
| S-T12SQ | AC200V |
| Specify from page 125. | Select the coil designation from page 43 or specify the control circuit voltage and frequency used. |

SD-T SQ Type

| Model Name | Operation Coil Designation or Control Circuit Voltage and Frequency |
|------------------------|---|
| SD-T12SQ | DC100V |
| Specify from page 125. | Select the coil designation from page 44 or specify the control circuit voltage and frequency used. |

11. Main Circuit 3-Pole Magnetic Contactors

S-T Type, S-2xT Type

| Model Name | Operation Coil Designation or Control Circuit Voltage and Frequency |
|------------------------|---|
| S-T32 | AC200V |
| Specify from page 127. | Select the coil designation from page 43 or specify the control circuit voltage and frequency used. |

SD-T Type, SD-2xT Type

| Model Name | Operation Coil Designation or Control Circuit Voltage and Frequency |
|------------------------|---|
| SD-T32 | DC100V |
| Specify from page 127. | Select the coil designation from page 44 or specify the control circuit voltage and frequency used. |