

Wattmeters

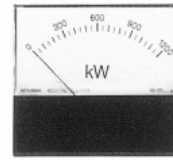

YP-208NW

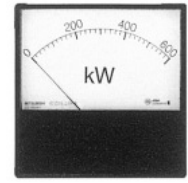

YP-10NW

Specifications

		Rectangular indicators																								
		Y-2N Series									Y-N Series															
Size (width × height)	mm	64×60			85×75			100×85			82×82			102×102												
Model name		YP-206NW			YP-208NW			YP-210NW			YP-8NW			YP-10NW												
Operation principle		Transducer									Transducer															
Accuracy (grade)		2.5									2.5															
Frequency		50 and 60Hz																								
Scale length	(mm)	55			70			85			70			90												
Weight	(kg)	0.07			0.1			0.1			0.1			0.15												
Indicator rating and delivery period classification	Circuit	Rating		Consumption VA			Accessory	Delivery period classification	Consumption VA			Accessory	Delivery period classification	Consumption VA			Accessory	Delivery period classification	Consumption VA			Accessory	Delivery period classification			
		Secondary rating	Indicator rating (Po) kW	Voltage circuit		Current circuit			Voltage circuit	Current circuit	Voltage circuit			Current circuit	Voltage circuit	Current circuit			Voltage circuit	Current circuit	Voltage circuit			Current circuit	Voltage circuit	Current circuit
				I ₁	I ₂																					
1-phase 2-wire	110V 5A	0.4~0.6	2.2	1.0	T-150	○	2.2	1.0	T-150	○	2.2	1.0	T-150	○	2.2	1.0	T-150	○	2.2	1.0	T-150	○				
	220V 5A	0.8~1.2	4.4	1.0	T-150	○	4.4	1.0	T-150	○	4.4	1.0	T-150	○	4.4	1.0	T-150	○	4.4	1.0	T-150	○				
1-phase 3-wire	100/200V 5A	0.8~1.2	1.6	0.5	T-150	○	1.6	0.5	T-150	○	1.6	0.5	T-150	○	1.6	0.5	T-150	○	1.6	0.5	T-150	○				
3-phase 3-wire	110V 5A	0.8~1.2	1.6	0.5	T-150	○	1.6	0.5	T-150	○	1.6	0.5	T-150	○	1.6	0.5	T-150	○	1.6	0.5	T-150	○				
	220V 5A	1.6~2.4	3.2	0.5	T-150	○	3.2	0.5	T-150	○	3.2	0.5	T-150	○	3.2	0.5	T-150	○	3.2	0.5	T-150	○				
3-phase 4-wire	110/√3 /110V 5A	0.8~1.2	1.6	0.5	1.0	T-150	○	1.6	0.5	1.0	T-150	○	1.6	0.5	1.0	T-150	○	1.6	0.5	1.0	T-150	○				
	110/190V 5A	1.4~2.0	2.8	0.5	1.0	T-150	○	2.8	0.5	1.0	T-150	○	2.8	0.5	1.0	T-150	○	2.8	0.5	1.0	T-150	○				
	220/380V 5A	2.8~4.0	3.5	0.5	1.0	T-150	○	3.5	0.5	1.0	T-150	○	3.5	0.5	1.0	T-150	○	3.5	0.5	1.0	T-150	○				
Page with outer dimensions drawing		35									36															

Remarks (1) In regards to "Indicator rating (Po) kW" in the "Rating" column:

- 1-phase, 2-wire wattmeters
 - Po=110V×5A=550≈0.5kW (Po=0.4 to 0.6kW, taking into account adjustment range multiplying factors of 0.8 to 1.2)
 - Po=220V×5A=1100≈1.0kW (Po=0.8 to 1.2kW, taking into account adjustment range multiplying factors of 0.8 to 1.2)
- 3-phase, 3-wire wattmeters
 - Po=√3×110V×5A=953≈1kW (Po=0.8 to 1.2kW, taking into account adjustment range multiplying factors of 0.8 to 1.2)
 - Po=√3×220V×5A=1906≈2kW (Po=1.6 to 2.4kW, taking into account adjustment range multiplying factors of 0.8 to 1.2)
- 3-phase, 4-wire wattmeters
 - Po=3× $\frac{110}{\sqrt{3}}$ ×5A=√3×110V×5A=953≈1kW (Po=0.8 to 1.2kW, taking into account adjustment range multiplying factors of 0.8 to 1.2)
 - Po=3×110V×5A=√3×190V×5A=1650≈1.7kW (Po=1.4 to 2.0kW, taking into account adjustment range multiplying factors of 0.8 to 1.2)
 - Po=3×220V×5A=√3×380V×5A=3300≈3.4kW (Po=2.8 to 4.0kW, taking into account adjustment range multiplying factors of 0.8 to 1.2)

(2) Bidirectional deflection indicators can also be manufactured.

(3) Models with a 1A current rating can also be manufactured; the power consumption is basically the same as that of a 5A model.

The indicator rating value in this case is calculated by substituting 1A in place of 5A in the equations of Remarks (1).

(4) The T-150 rectifier is a dedicated accessory (non-compatible accessory), and thus cannot be used in combinations other than those designated for the indicators. The distance between the indicator and the T-150 rectifier must be 5m or less, or the round-trip lead wire resistance must be 0.5Ω or less.

(5) The weight of the T-150 accessory rectifier is approximately 1kg.

(6) Use a wattmeter with an input voltage in the range of 85 to 115% of the rated value (rated voltage ±15%).

The indication may be unstable when used with an input voltage of 85% or less of the rating or the input voltage is switched on and off.

(7) Please make sure to read the "Safety Precautions" (pp.5-8) and the "Selection Precautions" (p.9) to assist in selecting the model and use specifications suited to the application.

Scale calculation formula for wattmeter

Phase-wire system	Secondary rating	Scale calculation formula for wattmeter	Remarks
1-phase 2-wire	110V 5A	Indicator scale P (kW)=VT ratio × CT ratio × Po (0.4~0.6)	●The value at the left is multiplied by 1/5 in the case of a CT secondary current of 1A.
	220V 5A	Indicator scale P (kW)=CT ratio × Po (0.8~1.2)	
1-phase 3-wire	100/200V 5A	Indicator scale P (kW)=CT ratio × Po (0.8~1.2)	
3-phase 3-wire	110V 5A	Indicator scale P (kW)=VT ratio × CT ratio × Po (0.8~1.2)	
	220V 5A	Indicator scale P (kW)=CT ratio × Po (1.6~2.4)	
3-phase 4-wire	$\frac{110}{\sqrt{3}}$ /110V 5A	Indicator scale P (kW)=VT ratio × CT ratio × Po (0.8~1.2)	
	110/190V 5A	Indicator scale P (kW)=VT ratio × CT ratio × Po (1.4~2.0)	
	220/380V 5A	Indicator scale P (kW)=VT ratio × CT ratio × Po (2.8~4.0)	

Calculation example: In the case of a 3-phase, 3-wire circuit, VT 6600/110V and CT 100/5A

$$\text{Indicator scale P (kW)} = \frac{6600}{110} \times \frac{100}{5} \times \text{Po (0.8~1.2)} = 960\sim 1440\text{kW}$$

Therefore, wattmeters can be manufactured with a scale of 960~1440kW.

This varies slightly according to the rating. Refer to the Wattmeter Scale Selection Reference Table on p.58 for details.



YP-12NW

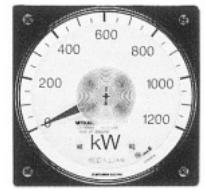

LP-110NW

Specifications

		Rectangular indicators						Wide-angle indicators										
		Y-N Series						L-N Series				L-N Series						
Size (width × height)	mm	122×122						80×80				110×110						
Model name		YP-12NW						LP-80NW				LP-110NW						
Operation principle		Transducer						Transducer										
Accuracy (grade)		1.5						2.5				1.5						
Frequency		50 and 60Hz																
Scale length	(mm)	100						124				175						
Weight	(kg)	0.5						0.3				0.6						
Indicator rating and delivery period classification	Circuit	Rating		Consumption VA			Accessory	Delivery period classification	Consumption VA			Accessory	Delivery period classification	Consumption VA			Accessory	Delivery period classification
		Secondary rating	Indicator rating (Po) kW	Voltage circuit	Current circuit				Voltage circuit	Current circuit				Voltage circuit	Current circuit			
	1-phase 1-wire	110V 5A	0.4~0.6	2.2	1.0		—	○	2.2	1.0		T-150	○	2.2	1.0		—	○
1-phase 2-wire	220V 5A	0.8~1.2	4.4	1.0		—	○	4.4	1.0		T-150	○	4.4	1.0		—	○	
1-phase 3-wire	100/200V 5A	0.8~1.2	1.6	0.5		—	○	1.6	0.5		T-150	○	1.6	0.5		—	○	
3-phase 3-wire	110V 5A	0.8~1.2	1.6	0.5		—	○	1.6	0.5		T-150	○	1.6	0.5		—	○	
	220V 5A	1.6~2.4	3.2	0.5		—	○	3.2	0.5		T-150	○	3.2	0.5		—	○	
	110/√3 /110V 5A	0.8~1.2	1.6	0.5	1.0	—	○	1.6	0.5	1.0	T-150	○	1.6	0.5	1.0	—	○	
	110/190V 5A	1.4~2.0	2.8	0.5	1.0	—	○	2.8	0.5	1.0	T-150	○	2.8	0.5	1.0	—	○	
3-phase 4-wire	220/380V 5A	2.8~4.0	3.5	0.5	1.0	—	○	3.5	0.5	1.0	T-150	○	3.5	0.5	1.0	—	○	
	Page with outer dimensions drawing						36						37					

Delivery period classification

Symbol	◎Standard product	○Quasi-standard product	△Special product
Reference delivery period	Immediate delivery	Within 20 days	21 to 60 days

Outer dimensions of accessories

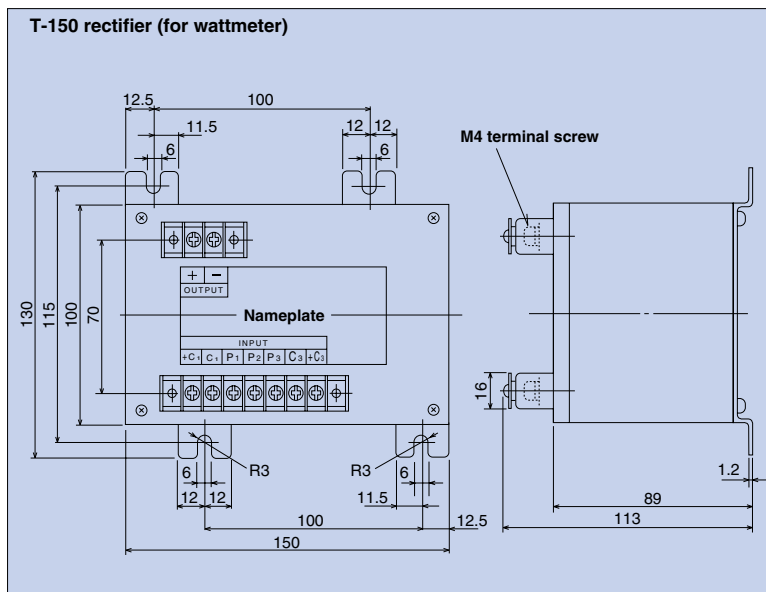

Terminal configuration

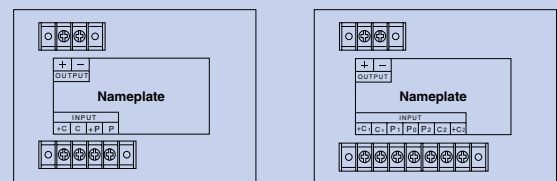

Fig. 1 For 1-phase, 2-wire system Fig. 2 For 1-phase, 3-wire system

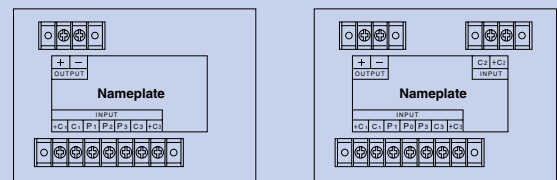
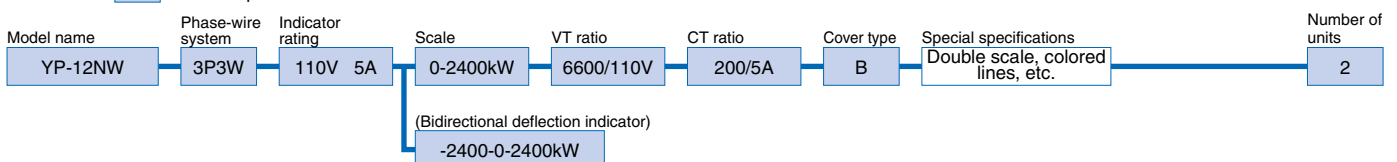

Fig. 3 For 3-phase, 3-wire system Fig. 4 For 3-phase, 4-wire system

Ordering method

The items in must be specified.



Connection diagrams

● 1-phase, 2-wire system

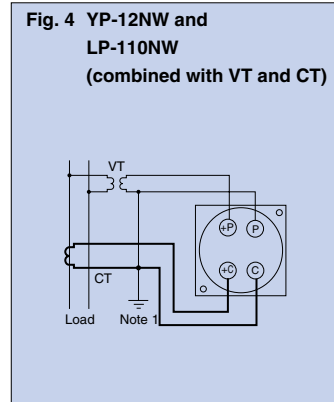
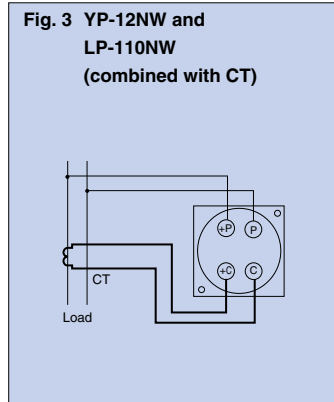
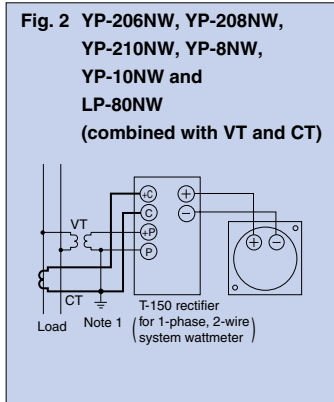
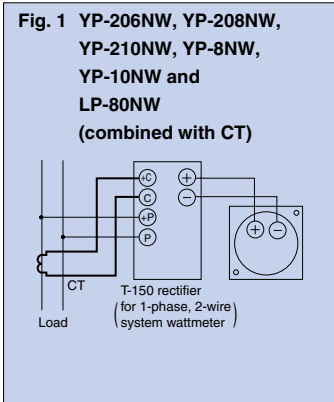

● 1-phase, 3-wire system

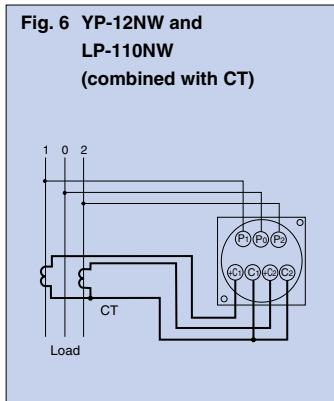
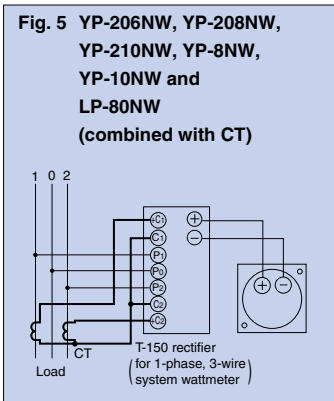

● 3-phase, 3-wire system

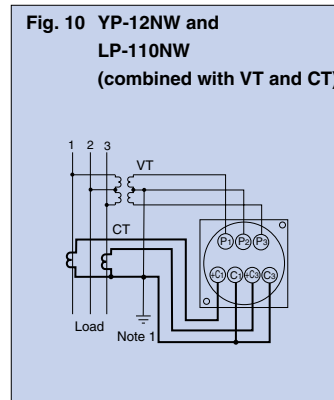
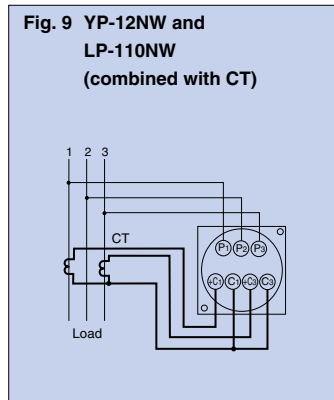
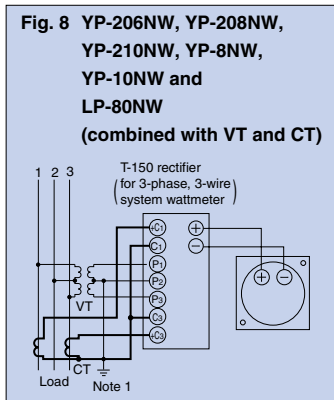
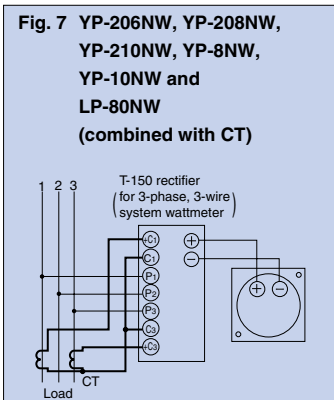

● 3-phase, 4-wire system

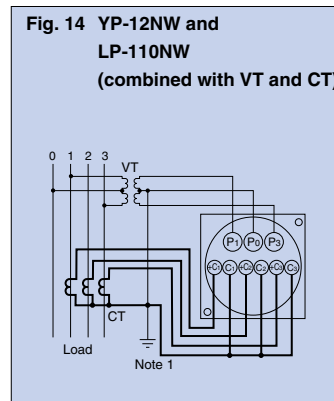
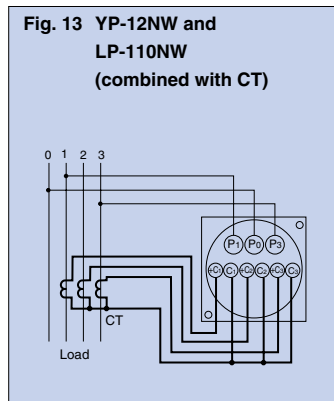
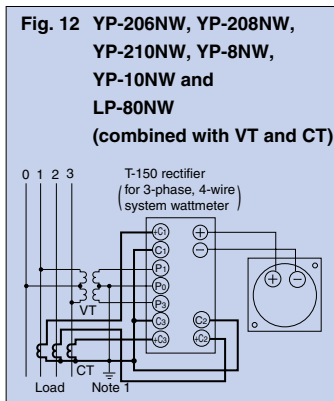
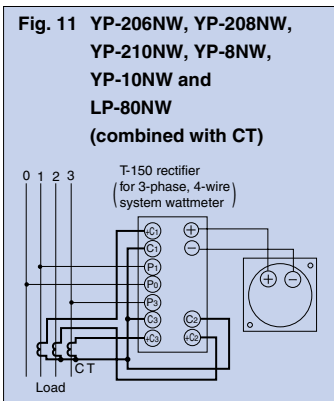

Note 1. For low-voltage circuits, grounding of the secondary sides of the instrument voltage transformer and current transformer is unnecessary.

Wattmeter Scale Selection Reference Table

Although the maximum scale of a wattmeter can be determined by VT ratio × CT ratio × indicator rating (Po), the following table shows the manufacturable scale values (minimum, standard and maximum) for various VT ratios and CT ratios.

If a scale value other than the standard value is desired, please specify a suitable scale within the manufacturable range.

Table of manufacturable maximum scales for wattmeters

□ : Scale units kW □ : Scale units MW

Phase-wire system		1-phase 2-wire			1-phase 3-wire	3-phase 3-wire/3-phase 4-wire								
CT ratio	Voltage VT ratio Manufacturable range	110	220	440	100/200	110	220	440	3300	6600	11000	22000	33000	66000
		—	220/110	440/110	—	—	220/110	440/110	3300 /110	6600 /110	11000 /110	22000 /110	33000 /110	66000 /110
25/5	Minimum	2	4	8	4	4	8	15	120	240	400	800	1200	2400
	Standard	2.5	5	10	5	5	10	20	150	300	500	1000	1500	3000
	Maximum	3	6	12	6	6	12	25	180	350	600	1200	1800	3500
50/5	Minimum	4	8	15	8	8	15	30	240	450	800	1500	2400	4500
	Standard	5	10	20	10	10	20	40	300	600	1000	2000	3000	6000
	Maximum	6	12	25	12	12	25	50	350	750	1200	2500	3500	7500
75/5	Minimum	6	12	24	12	12	24	45	350	700	1200	2400	3500	7000
	Standard	7.5	15	30	15	15	30	60	450	900	1500	3000	4500	9000
	Maximum	9	18	35	18	18	35	75	500	1000	1800	3500	5000	10000
100/5	Minimum	8	15	30	15	15	30	60	450	900	1500	3000	4500	9000
	Standard	10	20	40	20	20	40	80	600	1200	2000	4000	6000	12000
	Maximum	12	24	50	24	25	50	100	750	1500	2500	5000	7500	15000
150/5	Minimum	12	24	45	24	24	45	90	700	1400	2400	4500	7000	14000
	Standard	15	30	60	30	30	60	120	900	1800	3000	6000	9000	18000
	Maximum	18	35	75	35	35	75	150	1000	2000	3500	7500	10000	20000
200/5	Minimum	16	30	60	30	30	60	120	900	1800	3000	6000	9000	18000
	Standard	20	40	80	40	40	80	160	1200	2400	4000	8000	12000	24000
	Maximum	25	50	100	50	50	100	180	1500	3000	5000	10000	15000	30000
300/5	Minimum	24	45	90	45	45	90	180	1400	2800	4500	9000	14000	28000
	Standard	30	60	120	60	60	120	240	1800	3600	6000	12000	18000	36000
	Maximum	35	75	150	75	75	150	300	2000	4000	7500	15000	20000	40000
400/5	Minimum	30	60	120	60	60	120	250	1800	3800	6000	12000	18000	38000
	Standard	40	80	160	80	80	160	320	2400	4800	8000	16000	24000	48000
	Maximum	50	100	180	100	100	180	350	3000	6000	10000	20000	30000	60000
600/5	Minimum	45	90	180	90	90	180	380	2800	6000	9000	18000	28000	60000
	Standard	60	120	240	120	120	240	480	3600	7200	12000	24000	36000	72000
	Maximum	75	150	300	150	150	300	600	4000	8500	15000	30000	40000	85000
800/5	Minimum	60	120	250	120	120	250	500	3800	7500	12000	25000	38000	75000
	Standard	80	160	320	160	160	320	640	4800	9600	16000	32000	48000	96000
	Maximum	100	180	350	180	180	350	750	6000	12000	20000	35000	60000	120000
1200/5	Minimum	90	180	380	180	180	380	750	6000	12000	20000	38000	60000	120000
	Standard	120	240	480	240	240	480	960	7200	14400	24000	48000	72000	144000
	Maximum	150	300	600	300	300	600	1200	8500	18000	30000	60000	85000	180000
1500/5	Minimum	120	240	450	240	240	450	900	7000	14000	24000	45000	70000	140000
	Standard	150	300	600	300	300	600	1200	9000	18000	30000	60000	90000	180000
	Maximum	180	350	750	350	350	750	1500	10000	20000	35000	70000	100000	200000
2000/5	Minimum	160	300	600	300	300	600	1200	9000	18000	30000	60000	90000	180000
	Standard	200	400	800	400	400	800	1600	12000	24000	40000	80000	120000	240000
	Maximum	240	500	1000	500	500	1000	1800	15000	30000	50000	100000	150000	300000
3000/5	Minimum	240	450	900	450	450	900	1800	14000	28000	45000	90000	140000	280000
	Standard	300	600	1200	600	600	1200	2400	18000	36000	60000	120000	180000	360000
	Maximum	350	750	1500	750	750	1500	3000	20000	40000	75000	150000	200000	400000

Note 1. Some of the maximum scale values in the table deviate from the VT ratio × CT ratio × adjustment range multiplying factor. This is because the best values are selected, and the values in the table are given priority.

Rectangular indicators (Y-N Series)

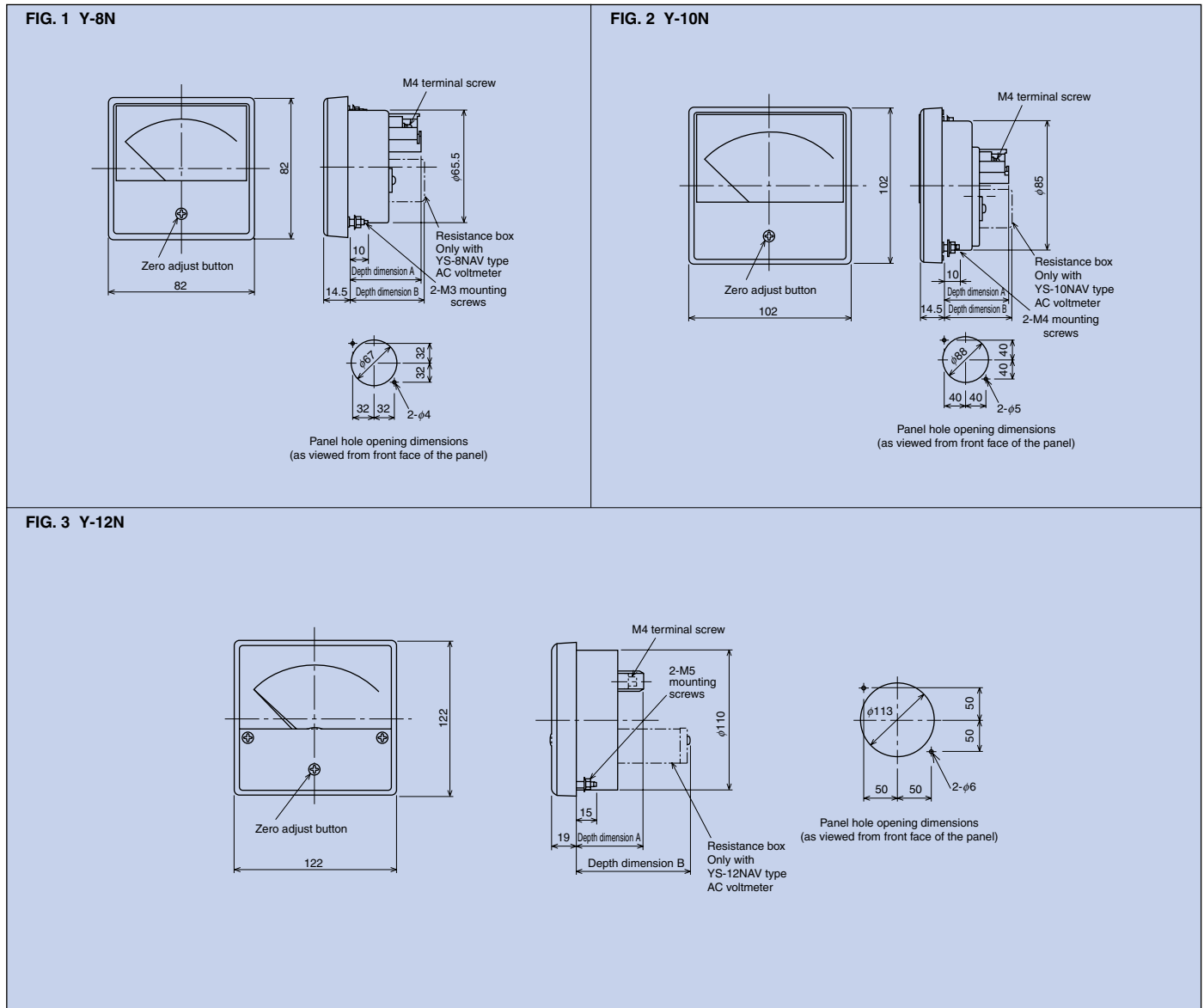

● Depth dimension details

Indicator type		Y-8N			Y-10N			Y-12N			
		Type name	A dimension	B dimension	Type name	A dimension	B dimension	Type name	A dimension	B dimension	
DC	Ammeters	YM-8NDA	41	—	YM-10NDA	41	—	YM-12NDA	50	—	
	Voltmeters	YM-8NDV	41	—	YM-10NDV	41	—	YM-12NDV	50	—	
AC	Ammeters	YS-8NAA	41	—	YS-10NAA	41	—	YS-12NAA	50	—	
		Uniform scale	YR-8NAA	41	—	YR-10NAA	41	—	YR-12NAA	50	—
	Voltmeters	YS-8NAV	41	43	YS-10NAV	41	43	YS-12NAV	50	85	
		Uniform scale	YR-8NAV	41	—	YR-10NAV	41	—	YR-12NAV	50	—
	Wattmeters	YP-8NW	41	—	YP-10NW	41	—	YP-12NW	100	—	
	Varmeters	YP-8NVAR	41	—	YP-10NVAR	41	—	YP-12NVAR	100	—	
	Power-factor meters	Balanced	YP-8NPF	81	—	YP-10NPF	81	—	YP-12NPF	50	Note
		Unbalanced	YP-8NPFU	41	—	YP-10NPFU	41	—	YP-12NPFU	100	—
Frequency meters	YP-8NF	81	—	YP-10NF	81	—	YP-12NF	50	—		
Receiving indicators	DC indicators	YM-8NRI	41	—	YM-10NRI	41	—	YM-12NRI	50	—	
	AC indicators	YR-8NRI	41	—	YR-10NRI	41	—	YR-12NRI	50	—	

Note. 100mm in the case of a model for 1-phase 2-wire systems.



Outer Dimension Drawings

(Refer to the specification tables regarding models other than the Y-2N series, Y-N series, and L-N series.)

Rectangular indicators (Y-2N Series)

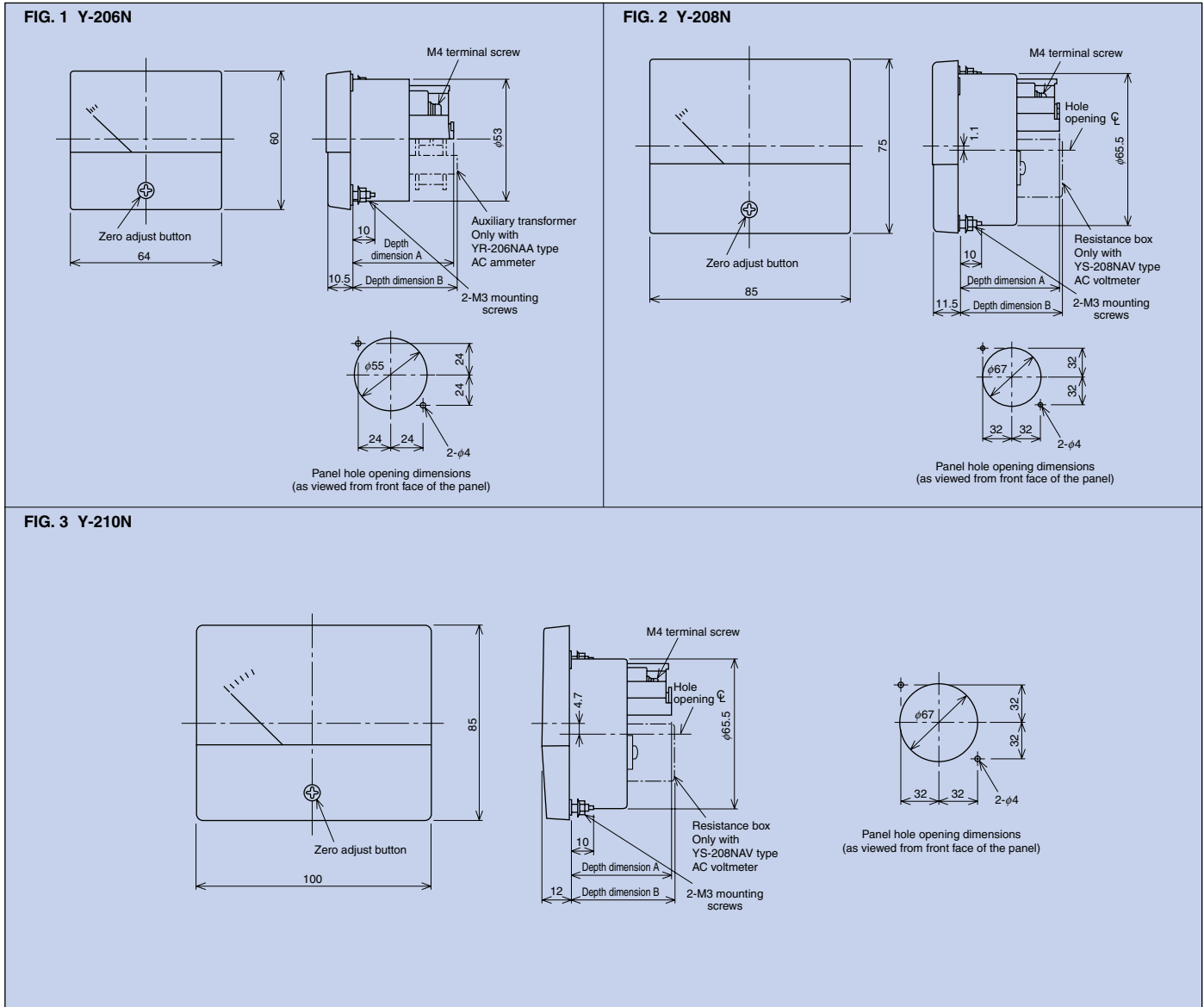

● Depth dimension details

Indicator type	Y-206N			Y-208N			Y-210N				
	Type name	A dimension	B dimension	Type name	A dimension	B dimension	Type name	A dimension	B dimension		
DC	Ammeters	YM-206NDA	43	—	YM-208NDA	43	—	YM-210NDA	43	—	
	Voltmeters	YM-206NDV	43	—	YM-208NDV	43	—	YM-210NDV	43	—	
AC	Ammeters	YS-206NAA	43	—	YS-208NAA	43	—	YS-210NAA	43	—	
		Uniform scale	YR-206NAA	43	44	YR-208NAA	43	—	YR-210NAA	43	—
	Voltmeters	YS-206NAV	43	—	YS-208NAV	43	45	YS-210NAV	43	45	
		Uniform scale	YR-206NAV	43	—	YR-208NAV	43	—	YR-210NAV	43	—
	Wattmeters	YP-206NW	43	—	YP-208NW	43	—	YP-210NW	43	—	
	Varmeters	YP-206NVAR	43	—	YP-208NVAR	43	—	YP-210NVAR	43	—	
	Power-factor meters	Balanced	YP-206NPF	43	—	YP-208NPF	43	—	YP-210NPF	43	—
		Unbalanced	YP-206NPFU	43	—	YP-208NPFU	43	—	YP-210NPFU	43	—
Frequency meters	YP-206NF	83	—	YP-208NF	83	—	YP-210NF	83	—		
Receiving indicators	DC indicators	YM-206NRI	43	—	YM-208NRI	43	—	YM-210NRI	43	—	
	AC indicators	YR-206NRI	43	—	YR-208NRI	43	—	YR-210NRI	43	—	



Outer Dimensional Drawings

(Refer to the specification tables regarding models other than the Y-2N series, Y-N series, and L-N series.)

Wide-angle indicators (L-N Series)

FIG. 1 L-80N

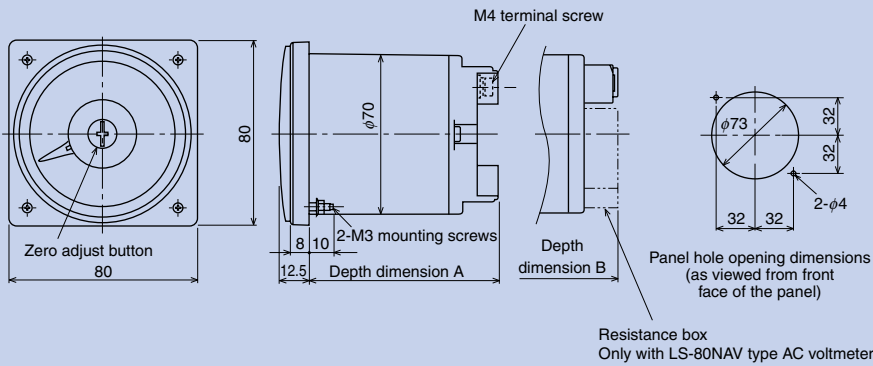

●Depth dimension details

Indicator type		L-80N			
		Type name	A dimension	B dimension	
DC	Ammeters	LM-80NDA	81	—	
	Voltmeters	LM-80NDV	81	—	
AC	Ammeters	LS-80NAA	—	81	
		Uniform scale LR-80NAA	81	—	
	Voltmeters	LS-80NAV	—	81	
		Uniform scale LR-80NAV	81	—	
	Wattmeters	LP-80NW	81	—	
	Varmeters	LP-80NVAR	81	—	
	Power-factor meters	Balanced	LP-80NPF	92	—
		Unbalance	LP-80NPFU	81	—
Frequency meters	LP-80NF	92	—		
Receiving indicators	DC indicators	LM-80NRI	81	—	
	AC indicators	LR-80NRI	81	—	



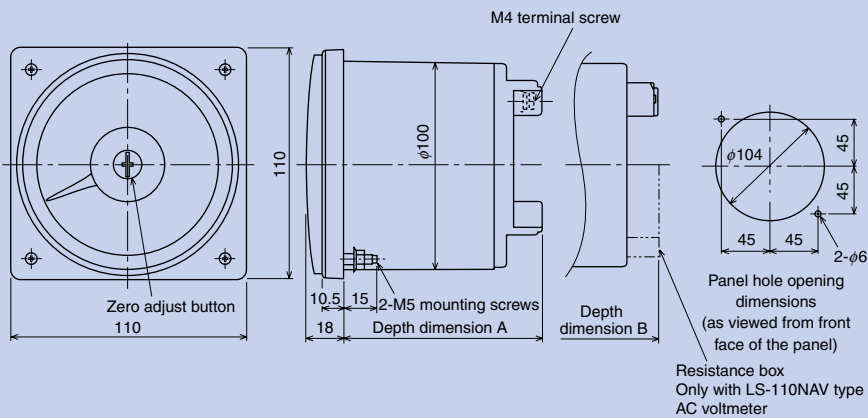

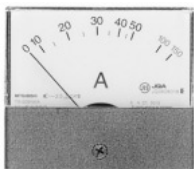

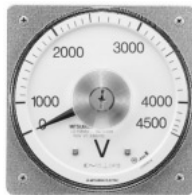



FIG. 2 L-110N



●Depth dimension details

Indicator type		L-110N			
		Type name	A dimension	B dimension	
DC	Ammeters	LM-110NDA	92	—	
	Voltmeters	LM-110NDV	92	—	
AC	Ammeters	LS-110NAA	—	92	
		Uniform scale LR-110NAA	92	—	
	Voltmeters	LS-110NAV	—	92	
		Uniform scale LR-110NAV	92	—	
	Wattmeters	LP-110NW	100	—	
	Varmeters	LP-110NVAR	100	—	
	Power-factor meters	Balanced	LP-110NPF	92	—
		Unbalance	LP-110NPFU	100	—
Frequency meters	LP-110NF	92	—		
Receiving indicators	DC indicators	LM-110NRI	92	—	
	AC indicators	LR-110NRI	92	—	

Covers

Cover specification	Classification	Y-2N Series	Y-N Series	L-N Series
B design cover (Munsell N 1.5 semi-gloss)	◎			
G design cover (all transparent)	○			—
F design cover ^{Note 1} (special color coating)	△			
Cover with red needle (can be manufactured for B, G, and F designs)	○			

Remarks The B design cover is standard specification. The G and F design covers and covers with red needles can be manufactured if required.

Note 1. When ordering the F-design cover, please use F as the cover code and specify the color coating. Munsell 7.5BG 4/1.5 will be used for orders with no color coating specified.

Cover codes

Cover specifications	Without red needle	With red needle
B design	B	BR*1
G design	G	GR
F design	F	FR

Remarks For the Y-N Series, a B cover with two red needles (BRR cover) can be manufactured depending on the model (please inquire for details).

Accessories

Nuts for mounting screws are provided with all models. T-150 and other special accessories are indicated in the specification columns of the respective indicator types.

Mechanical Indicators

Common Specifications

Scale plate components and items indicated

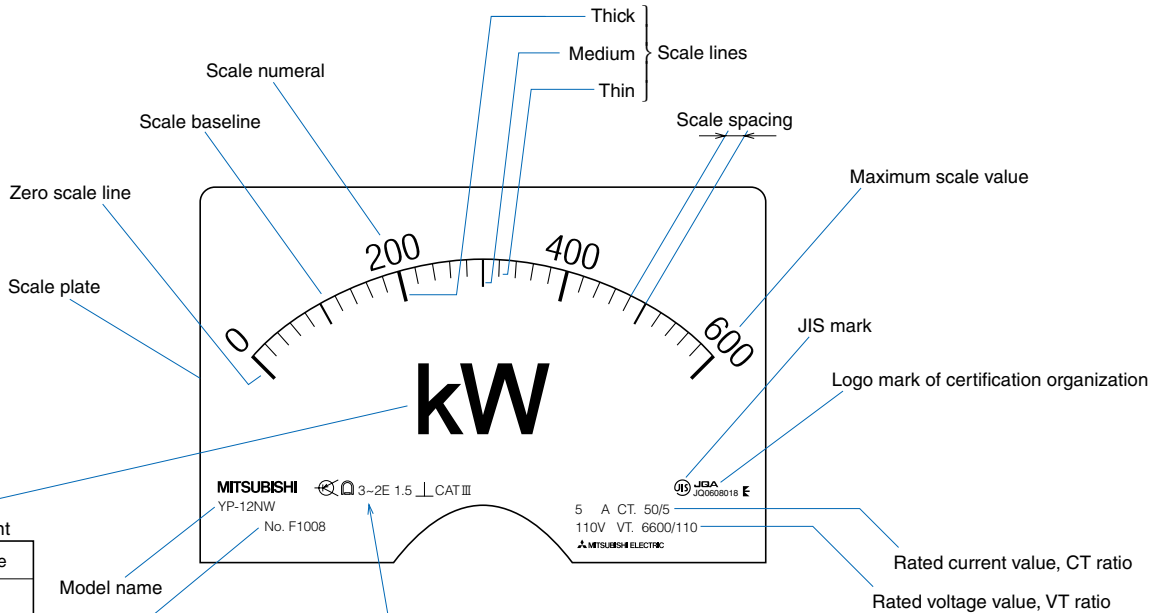

Unit of measurement

Item	Code
Ampere	A
Volt	V
Watt	W
Var	var
Power factor	cos ϕ or cos ψ
Hertz	Hz
Prefix	
Mega 10^6	M
Kilo 10^3	k
Milli 10^{-3}	m

Model name
Serial number

⊗ 3~2E 1.5 ⊥ CAT III

Auxiliary symbols

Item	Symbol
Shunt	
Serial resistor	
Accessory	

Operation principle

Item	Symbol
Permanent magnet/movable coil	
Movable iron core	
Bimetal	
Electronic device in measurement circuit	
Electronic device in auxiliary circuit	
Rectifier	

Type of measurement and number of elements measured

Item	Symbol
DC circuit	
AC circuit	
3-phase AC circuit	3~
Single element for 3-wire circuit	3-1E
Two elements for unbalanced load 3-wire circuit	3~2E
Two elements for unbalanced load 4-wire circuit	3N~2E
Three elements for unbalanced load 4-wire circuit	3N~3E

Accuracy class

Class index	Code
Class 0.5	0.5
Class 1	1
Class 1.5	1.5
Class 2.5	2.5
Class 5	5
Class 1.5 in the case where the base value corresponds to the span	1.5
Class 2.5 in the case where the base value corresponds to the span	2.5

Mounting attitude

Item	Symbol
Instrument used with scale plate set vertically	
Instrument used with scale plate set horizontally	
Instrument used with scale plate set at a position inclined from the horizontal surface (example: 60°)	

Measurement category

Classification	Code
Measurement category III	CAT III

Scale plate indications

The following tables show the scales, including numerals, colored lines, bands and colors, used as standard specifications. Red, blue, green and yellow are used for the colored lines/bands.

	Y-2N Series	Y-N Series	L-N Series
Standard scale			
Expanded scale (expanded by 3 times)			
Positive/Negative scale			
Single scale with double stamp			
Double scale with double stamp			
Colored lines Colored bands			

Remarks (1) See the "Standard Scale Diagrams" on pp.31 to 34 regarding the scale division with respect to the maximum scale value.
 (2) Special scales can also be manufactured.